

AGENDA

CITY OF HOUSTON ■ CITY COUNCIL

September 24 & 25, 2024

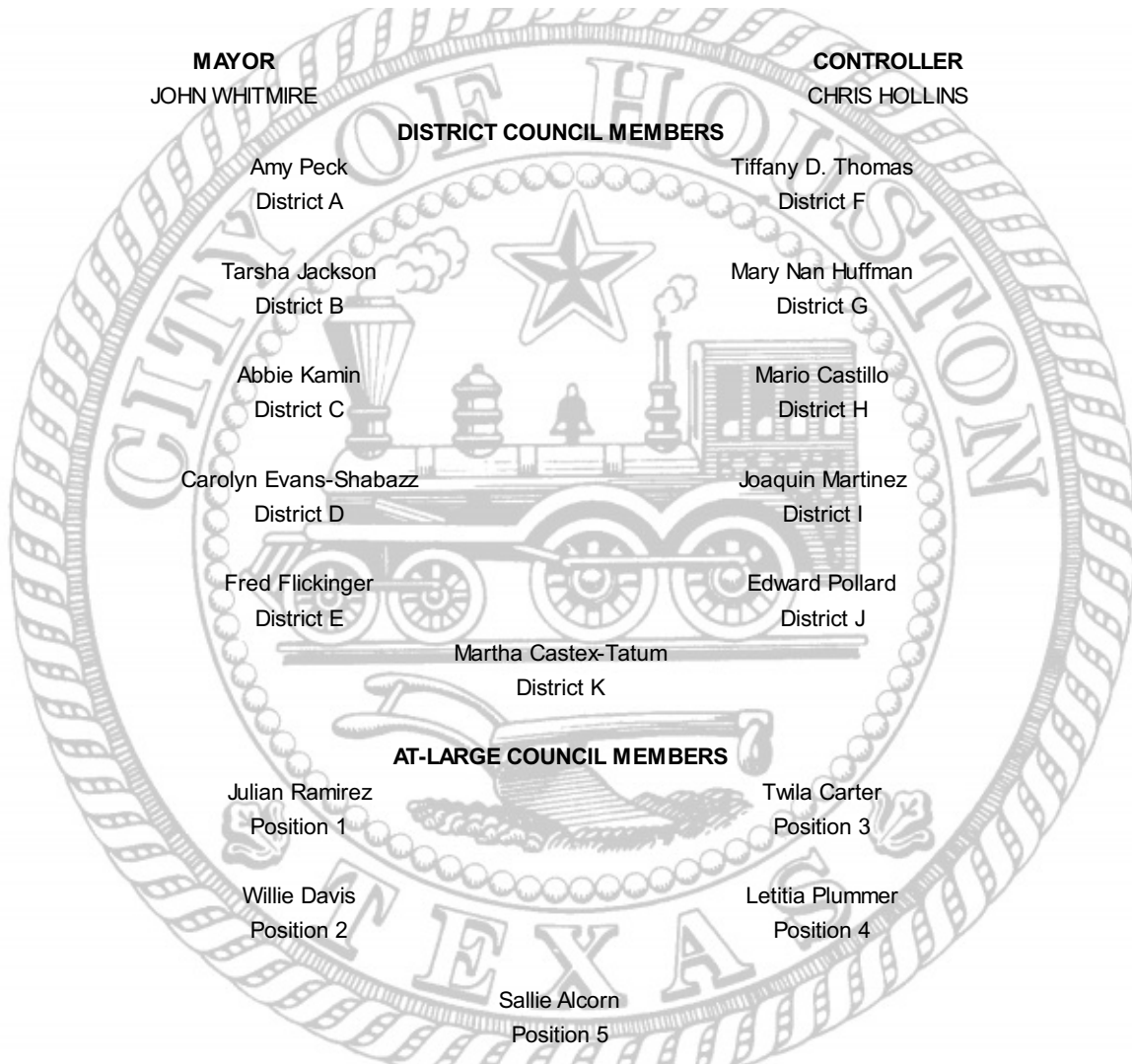

MAYOR
JOHN WHITMIRE

CONTROLLER
CHRIS HOLLINS

DISTRICT COUNCIL MEMBERS

Amy Peck
District A

Tiffany D. Thomas
District F

Tarsha Jackson
District B

Mary Nan Huffman
District G

Abbie Kamin
District C

Mario Castillo
District H

Carolyn Evans-Shabazz
District D

Joaquin Martinez
District I

Fred Flickinger
District E

Edward Pollard
District J

Martha Castex-Tatum
District K

AT-LARGE COUNCIL MEMBERS

Julian Ramirez
Position 1

Twila Carter
Position 3

Willie Davis
Position 2

Letitia Plummer
Position 4

Sallie Alcorn
Position 5

Marta Crinejo, Agenda Director

Pat Jefferson Daniel, City Secretary

In accordance with the Texas Open Meetings Act the agenda is posted for public information, at all times, for at least 72 hours preceding the scheduled time of the meeting on the bulletin board located on the exterior wall of the City Hall building at 901 Bagby.

The agenda may be accessed via the Internet at <http://houston.novusagenda.com/agendapublic/>. Copies of the agenda are available in the Office of the City Secretary in the City Hall Annex, Public Level at no charge. To receive the agenda by mail, send check or money order for \$52.00 for a one year subscription, made payable to the City of Houston to the attention of the City Secretary, P.O. Box 1562, Houston, Texas 77251.

To reserve time to appear before Council call 832-393-1100, or email us at speakers@houstontx.gov or weather permitting you may come to the Office of the City Secretary, City Hall Annex, Public Level **by 3:00 pm the Monday before Public Session.**

NOTE: If a translator is required, please advise when reserving time to speak

AGENDA - COUNCIL MEETING Tuesday, September 24, 2024 - 1:30 PM
City Hall - In Person Meeting

PRESENTATIONS

2:00 P.M. – INVOCATION AND PLEDGE OF ALLEGIANCE

INVOCATION AND PLEDGE OF ALLEGIANCE - Council Member Martinez

ROLL CALL AND ADOPT THE MINUTES OF THE PREVIOUS MEETING

PUBLIC SPEAKERS - Pursuant to City Council Rule 8, City Council will hear from members of the public; the names and subject matters of persons who had requested to speak at the time of posting this Agenda are attached; the names and subject matters of persons who subsequently request to speak may be obtained in the City Secretary's Office.

NOTE: If a translator is required, please advise when reserving time to speak

Speakers List

RECESS

RECONVENE

WEDNESDAY - SEPTEMBER 25th, 2024 - 9:00 A. M.

DESCRIPTIONS OR CAPTIONS OF AGENDA ITEMS WILL BE READ BY
THE
CITY SECRETARY PRIOR TO COMMENCEMENT

MAYOR'S REPORT

CONSENT AGENDA NUMBERS 1 through 40

MISCELLANEOUS - NUMBER 1

1. REQUEST from Mayor for confirmation of the appointment or reappointment of the following individuals to the **HOUSTON FORENSIC SCIENCE CENTER, INC**:
 - Position One - **ELLEN COHEN**, reappointment, for a term to expire 6/30/2027, and to serve as Chair
 - Position Three - **PHILIP H. HILDER**, reappointment, for a term to expire 6/30/2027
 - Position Five - **SONIA CORRALES**, appointment, for a term to expire 6/30/2027
 - Position Six - **JORN (CHI-CHUNG) YU**, appointment, for an unexpired term ending 6/30/2026
 - Position Seven - **ASMA H. MIRZA**, appointment, for a term to expire

6/30/2027

Position Nine - **VICKI HUFF**, reappointment, for a term to expire

6/30/2027

ACCEPT WORK - NUMBERS 2 and 3

2. RECOMMENDATION from Director General Services Department for approval of final contract amount of \$354,982.39 and acceptance of work on contract with **DNB ENTERPRISES, INC** for Underground Storage Tank Removal (UST), Remediation and Installation at Fire Station 82 - 4.20% under the original contract amount - **DISTRICT K - CASTEX-TATUM**
3. RECOMMENDATION from Chief Operating Officer, Houston Public Works for approval of final contract amount of \$2,483,377.42 and acceptance of work on contract with **LEM CONSTRUCTION COMPANY, INC** for Keegans Bayou, Northwest and Chocolate Bayou Wastewater Treatment Plants (WWTP) Bar Screen and Grating Replacement - 4.88% under the original contract amount - **DISTRICTS A - PECK; D - EVANS-SHABAZZ and J - POLLARD**

PROPERTY - NUMBER 4

4. RECOMMENDATION from the City Attorney in connection with eminent domain proceeding styled City of Houston v. Almeria Holdings LLC., et al.; Cause No.1215685, for the acquisition of Parcels KY23-290, KY23-291, KY23-292, TCY23-058 and TCY23-059 for the **48-INCH WATERLINE FROM 288 TO CULLEN BOULEVARD ALONG EAST OREM DRIVE PROJECT - DISTRICT D - EVANS-SHABAZZ**

PURCHASING AND TABULATION OF BIDS - NUMBERS 5 through 16

5. **HI-LITE AIRFIELD SERVICES, LLC**. for Emergency Purchase of Rubber Removal Services for the Houston Airport System - \$426,259.68 - Enterprise Fund
6. APPROVE spending authority in the amount not to exceed \$692,094.26 for ShopKey Software License Renewal for the Fleet Management Department from the Cooperative Sourcewell **SNAP-ON INDUSTRIAL, a division of IDSC HOLDINGS, LLC** - 5 Years - Fleet Management Fund
7. APPROVE spending authority in the amount not to exceed \$6,089,838.90 for Purchase of Petersen and New Way Replacement Parts and Repair Services from **TEXAS PACKER AND LOADER SALES, INC dba TEXAS PACK + LOAD** for the Fleet Management Department - 3 Years with 2 one-year options - Fleet Management Fund
8. APPROVE spending authority in an amount not to exceed \$100,000.00 for Emergency Purchase and Delivery of Fuel for the Fleet Management Department from **SUN COAST RESOURCES, LLC** - Fleet Management Fund

9. **SIDDONS MARTIN EMERGENCY GROUP, LLC** for McNeilus Refuse Body Replacement Parts and Repair Services for the Fleet Management Department - 3 Years with 2 one-year options - \$8,332,362.70 - Fleet Management Fund
10. **SILSBEE FORD** for Purchase of Ford Maverick Hybrid Trucks through The Interlocal Purchasing System (TIPS) for the Fleet Management Department on behalf of the Houston Police Department - \$90,857.25 - Equipment Acquisition Consolidated Fund
11. APPROVE spending authority in the total amount of \$139,293.00 for Purchase of Network Application Services and Hardware for Houston Television from the sole source supplier, **CREED GLOBAL MEDIA, LLC dba CREED GLOBAL MEDIA** - 2 Years - State Cable TV Fund
12. **HELENA AGRI-ENTERPRISES, LLC**, the Texas Local Government Purchasing Cooperative supplier for Purchase of Fertilizer for the Parks and Recreation Department - \$102,681.00 - Parks Golf Special Fund
13. **SIMPLOT AB RETAIL INC** - \$99,994.00 and **HARRELL'S LLC** - \$59,285.50 for Purchase of Fertilizer and Herbicide through the Texas Local Government Purchasing Cooperative (BuyBoard) suppliers for the Parks and Recreation Department - \$195,279.50 - Parks Golf Special Fund
14. **BWI COMPANIES, INC** for Purchase of Fungicide and Insecticide through the Texas Local Government Purchasing Cooperative (BuyBoard) supplier for the Parks and Recreation Department - \$95,363.90 - Parks Golf Special Fund
15. **HERITAGE PPG** for Purchase of Grass Seed through the Texas Local Government Purchasing Cooperative (BuyBoard) supplier for the Parks and Recreation Department - \$213,365.60 - Parks Golf Special Fund
16. **CANUCK POWER, INC.** for Signposts and associated hardware for Houston Public Works - 3 Years with 2 one-year options - \$3,003,400.00 - Special Revenue Fund

RESOLUTIONS - NUMBERS 17 through 20

17. RESOLUTION of the City Council of the City of Houston casting its vote for **JOE ZIMMERMAN, MAYOR**, City of Sugar Land, Texas, for Region 14 Director on the Texas Municipal League Board of Directors
18. RESOLUTION confirming approval of proposed Affordable Multifamily Residential Developments seeking exemption from taxation, with each development being owned by a Public Facility Corporation created and existing under Chapter 303 of the Texas Local Government Code and located in the City of Houston, Texas - **DISTRICTS A - PECK; D - EVANS-SHABAZZ and K - CASTEX-TATUM**
19. RESOLUTION authorizing issuance of Letter of Approval to **B&N EXPRESS EMS INC** pursuant to Section 773.0573 of the Texas Health and Safety Code
20. RESOLUTION authorizing issuance of Letter of Approval to **IMPACT EMS** pursuant to Section 773.0573 of the Texas Health and Safety Code

ORDINANCES - NUMBERS 21 through 40

21. ORDINANCE appropriating \$100,000.00 out of FY25 Equipment Acquisition Consolidated Fund for Analog/Plain Old Telephone System Service Replacement Project for Houston Information Technology Services
22. ORDINANCE appropriating \$100,000.00 out of FY25 Equipment Acquisition Consolidated Fund for CAD Infrastructure Refresh Project for Houston Information Technology Services
23. ORDINANCE approving and authorizing second amendment to extend contract term between City of Houston and (1) **ALPHA EYECARE ASSOCIATES PLLC**, (2) **CHINESE COMMUNITY CENTER**, (3) **ENTRAMED, INC. dba SENTIDO HEALTH**, (4) **HOME DELIVERY INCONTINENT SUPPLIES CO.**, (5) **MERC MEDICAL SUPPLY**, (6) **MONARCH ENDEAVORS LLC dba SYNERGY OF NORTHWEST HOUSTON**, (7) **TEXAS SOUTHERN UNIVERSITY**, (8) **UNIVERSITY OF TEXAS HEALTH SCIENCE CENTER AT HOUSTON**, (9) **MJC AUDIOLOGY CONSULTANT, LLC** (10) **INTERFAITH CARE PARTNERS**, (11) **ALZHEIMER'S DISEASE AND RELATED DISORDERS**, (12) **BAKERRIPLEY**, (13) **DINSMORE MEDICAL SYSTEMS LLC**, (14) **EVELYN RUBENSTEIN JEWISH COMMUNITY CENTER-VISITING**, (15) **HEARING AID EXPRESS**, (16) **HEIGHT HEARING AIDS, LLC**, (17) **MONTROSE COUNSELING CENTER**, (18) **PERRY LEE HOME HEALTH**, (19) **SYNERGY- KATY- HASELDEN HOMECARE LLC**, (20) **SYNERGY CONROE-MOSHER INITIATIVES INC**, for Aging and Caregiver Supportive Services to senior adults through the Harris County Area Agency on Aging for the Houston Health Department
24. ORDINANCE approving and awarding Professional Services Agreement between City of Houston and **MASTERSON ADVISORS, LLC** for Financial Advisory Services for the Finance Department; providing a maximum contract amount - 3 Years with 2 one-year options - \$4,845,000.00 - Enterprise and Other Funds
25. PULLED - This item will not be considered on Wednesday September 25
ORDINANCE amending Ordinance No. 2022-0678 to increase maximum contract amount for Professional Services Agreement between City of Houston and **THOMPSON CONSULTING SERVICES, LLC.**, for continued Disaster Debris Monitoring Services for the Solid Waste Department - \$16,000,000.00 - General Fund
26. ORDINANCE approving and authorizing Sole Source Agreement between City of Houston and **ASPYRA, LLC** for Hardware, Software, Maintenance, and Support Services for Cyberlab Laboratory Information System for the Houston Health Department; providing a maximum contract amount - 1 Year with 4 one-year terms - \$504,468.52 - Laboratory Services Fund
27. ORDINANCE approving and authorizing Sole Source Agreement between City of Houston and **THANKS AGAIN, LLC d/b/a GLIDEPATHCX** for Airport Concessions Loyalty Rewards Program for the Houston Airport System; providing a maximum contract amount - 2 Years with 1 one-year

option - \$1,200,000.00 - Enterprise Fund

28. ORDINANCE approving and authorizing contract between City of Houston and **NURSE-FAMILY PARTNERSHIP** for Administration and Management of Nurse Family Partnership Program for the Houston Health Department; providing a maximum contract amount - 1 Year with 4 one-year options - \$425,000.00 - Grant Fund
29. ORDINANCE appropriating \$17,245,906.03 out of City of Houston, Texas, Tax Increment Funds for **REINVESTMENT ZONES TWO (MIDTOWN ZONE), THREE (MAIN STREET/MARKET SQUARE ZONE), ELEVEN (GREATER GREENSPPOINT ZONE), FIFTEEN (EAST DOWNTOWN ZONE), and TWENTY-FIVE (HIRAM CLARKE FORT BEND ZONE)**, for payment to **HARRIS COUNTY, TEXAS**, for Affordable Housing, Payment of Administrative Expenses, and Payments to certain Redevelopment Authorities as provided herein
30. ORDINANCE appropriating \$27,102,306.00 out of City of Houston, Texas Tax Increment Funds for **REINVESTMENT ZONE NUMBERS ONE (SAINT GEORGE PLACE ZONE), TWO (MIDTOWN ZONE), THREE (MAIN STREET/MARKET SQUARE ZONE), SIX (EASTSIDE ZONE), SEVEN (OLD SPANISH TRAIL/ALMEDA CORRIDORS ZONE), EIGHT (GULFGATE ZONE), TWELVE (CITY PARK ZONE), THIRTEEN (OLD SIXTH WARD ZONE), FOURTEEN (FOURTH WARD ZONE), FIFTEEN (EAST DOWNTOWN ZONE), SIXTEEN (UPTOWN ZONE), AND EIGHTEEN (FIFTH WARD ZONE)**, City of Houston, Texas, for payment of affordable housing costs, payments to **HOUSTON INDEPENDENT SCHOOL DISTRICT**, and payments to certain redevelopment authorities as provided herein
31. ORDINANCE designating the property municipally known as **5613 Almeda Road, Houston, TX 77004** and also known as “Braswell Building” being located within the City of Houston, Texas, as a Protected Landmark; containing findings and other provisions related to the foregoing subject; providing for a penalty - **DISTRICT D - EVANS-SHABAZZ**
32. ORDINANCE consenting to the addition of 34.1226 acres of land to **PORTER MUNICIPAL UTILITY DISTRICT**, for inclusion in its district
33. ORDINANCE consenting to the addition of 0.717 acres of land to **HARRIS COUNTY MUNICIPAL UTILITY DISTRICT NO. 477**, for inclusion in its district
34. ORDINANCE approving and authorizing Full and Final Settlement, Indemnity Agreement and Release between City of Houston and **EVOQUA WATER TECHNOLOGIES, LLC** for Calcium Nitrate for Houston Public Works; providing a settlement amount - \$198,569.52 - Enterprise Fund
35. ORDINANCE appropriating \$1,412,558.00 out of Dedicated Drainage and Street Renewal Capital Fund – Ad Valorem Tax; approving and authorizing agreement for Right-of-Way Utility Adjustments between City of Houston, **SUNOCO PIPELINE L.P.**, and **ETP CRUDE LLC** for relocation of two 8-inch pipelines to accommodate the widening of Greens Road; providing funding for CIP Cost Recovery - **DISTRICT B - JACKSON**
36. ORDINANCE awarding Professional Services Contract to **TANKO**

- STREETLIGHTING, INC** for Nationwide Streetlight Ownership and Maintenance Plan for Houston Public Works; providing a maximum contract amount - 2 Years with 2 one-year options - \$265,552.00 - Dedicated Drainage and Street Renewal Fund – Metro et al
37. ORDINANCE appropriating \$4,454,854.00 out of Water & Sewer System Consolidated Construction Fund; approving and authorizing Professional Engineering Services Contract between City of Houston and **LOCKWOOD, ANDREWS & NEWNAM, INC** for Capacity Remedial Measures Plan (CRMP) Package 8 – Area 1 – Basin IB043; providing funding for CIP Cost Recovery relating to construction of facilities financed by the Water & Sewer System Consolidated Construction Fund - **DISTRICT B - JACKSON**
38. PULLED - This item will not be considered on Wednesday September 25
ORDINANCE appropriating \$1,376,874.75 out of Water & Sewer System Consolidated Construction Fund; approving and authorizing first amendment to Professional Engineering Services Contract between City of Houston and **OMEGA ENGINEERS, INC** for Work Order Engineering Services for Capacity Remedial Measures Plan for Package #2 (as approved by Ordinance No. 2021-0244) - **DISTRICT I - MARTINEZ**
39. ORDINANCE appropriating \$33,740,000.00 out of Water & Sewer System Consolidated Construction Fund, awarding contract to **PATE GARVER, LP** for Easthaven WWTP Flow Diversion Package 1; setting a deadline for the bidder's execution of the contract and delivery of all bonds, insurance, and other required contract documents to the City; holding the bidder in default if it fails to meet the deadlines; providing funding for CIP Cost Recovery relating to construction of facilities financed by the Water & Sewer System Consolidated Construction Fund; contingency, testing services, and construction management - **DISTRICT I - MARTINEZ**
40. ORDINANCE appropriating \$5,418,247.50 out of Dedicated Drainage and Street Renewal Capital Fund – Ad Valorem Tax; awarding contract to **TRAFFIC SYSTEMS CONSTRUCTION, INC** for Traffic Signal Work Order FY24 #1; setting a deadline for the bidder's execution of the contract and delivery of all bonds, insurance, and other required contract documents to the City; holding the bidder in default if it fails to meet the deadlines; providing funding for testing services and CIP Cost Recovery relating to construction of facilities financed by the Dedicated Drainage and Street Renewal Capital Fund – Ad Valorem Tax

END OF CONSENT AGENDA

CONSIDERATION OF MATTERS REMOVED FROM CONSENT AGENDA

MATTERS HELD - NUMBERS 41 through 43

41. ORDINANCE approving and authorizing Director of City of Houston Health Department to apply, accept, and expend Grant Award from **ENVIRONMENTAL PROTECTION AGENCY** for Environmental and Climate Justice Community Change Grants Program
TAGGED BY COUNCIL MEMBERS RAMIREZ and PLUMMER
This was Item 17 on Agenda of September 18, 2024

42. ORDINANCE appropriating \$4,440,000.00 out of Water & Sewer System Consolidated Construction Fund; awarding contract to **GRAVA, LLC** for Westheimer Work Orders for Small Diameter Water Lines; setting a deadline for the bidder's execution of the contract and delivery of all bonds, insurance, and other required contract documents to the City; holding the bidder in default if it fails to meet the deadlines; providing funding for testing services, early completion bonus allowance, and CIP Cost Recovery relating to construction of facilities financed by the Water & Sewer System Consolidated Construction Fund

TAGGED BY COUNCIL MEMBERS KAMIN

This was Item 34 on Agenda of September 18, 2024

43. **PROPOSITION A COUNCIL MEMBER ITEM**

ORDINANCE amending Sections 40-553 and 40-560 of the Code of Ordinances, Houston, Texas, relating to the required approval of a Sidewalk Plan or payment of a fee-in-lieu thereof for the construction of a new single-family residential use, other than a secondary dwelling unit

TAGGED BY COUNCIL MEMBER THOMAS

This was Item 36 on Agenda of September 18, 2024

MATTERS TO BE PRESENTED BY COUNCIL - Council Member Thomas first

ALL ORDINANCES ARE TO BE CONSIDERED ON AN EMERGENCY BASIS AND TO BE PASSED ON ONE READING UNLESS OTHERWISE NOTED, ARTICLE VII, SECTION 7, CITY CHARTER

NOTE WHENEVER ANY AGENDA ITEM, WHETHER OR NOT ON THE CONSENT AGENDA, IS NOT READY FOR COUNCIL ACTION AT THE TIME IT IS REACHED ON THE AGENDA, THAT ITEM SHALL BE PLACED AT THE END OF THE AGENDA FOR ACTION BY COUNCIL WHEN ALL OTHER AGENDA ITEMS HAVE BEEN CONSIDERED.

CITY COUNCIL RESERVES THE RIGHT TO TAKE UP AGENDA ITEMS OUT OF THE ORDER IN WHICH THEY ARE POSITIONED IN THIS AGENDA. ALSO, AN ITEM THAT HAS BEEN TAGGED UNDER CITY COUNCIL RULE (HOUSTON CITY CODE 2-2) OR DELAYED TO ANOTHER DAY MAY BE NEVERTHELESS CONSIDERED LATER AT THE SAME CITY COUNCIL MEETING.



CITY OF HOUSTON - CITY COUNCIL

Meeting Date: 9/24/2024

Item Creation Date:

Speakers List

Agenda Item#:

ATTACHMENTS:

Description	Type
--------------------	-------------

SP09-24-24.pdf	Signed Cover sheet
----------------	--------------------

**CITY COUNCIL CHAMBER – CITY HALL 2nd FLOOR - TUESDAY
SEPTEMBER 24, 2024 – 2:00 PM**

xxx TOTAL MINUTES

AGENDA

2 MIN

2 MIN

2 MIN

3 MIN

3 MIN

3 MIN

NON-AGENDA

1 MIN

1 MIN

1 MIN

2 MIN

2 MIN

2 MIN

3 MIN

3 MIN

3 MIN

MICHELLE IGUNBOR – 16114 Appleyard Ln. - Hockley – 77447 – 832-951-7964 – Police harassment

EDNA FORTE – 3911 Southmore Circle – 77004 – 832-656-7194 – Drainage prioritizing

DEBORAH ELAINE ALLEN – 8625 Winkler Dr. – 77013 – 832-887-0858 – Christopher McLaine given 99 years

NANCY HIGGS – 2109 Driscoll St. - 77019 – 512-422-3317 – Montrose trees

GEORGE LaBLANCHE – 12806 Southspring St. – 77047 – 832-901-5109 – Solid Waste

HAROLD SCOTT – 1826 Creegan Park Ct. – 77047 – 832-897-2814 – Humanity issues

BARBARA REDLINGER – 7729 Augusta Pines Dr. #204 – Spring – 77389 – 713-269-8396 – Problems experienced during Beryl

QUEEN PAIGE – Homeless – 281-987-0282 – City of Houston employees

STEVE WILLIAMS – Homeless - 346-648-9132 – The last 15 days

PREVIOUS

1 MIN

1 MIN

1 MIN



CITY OF HOUSTON - CITY COUNCIL

Meeting Date: 9/24/2024

Item Creation Date: 9/19/2024

MYR ~ 2024 Houston Forensic Science Center Appt. ltr. 9-19-24

Agenda Item#: 1.

Summary:

REQUEST from Mayor for confirmation of the appointment or reappointment of the following individuals to the **HOUSTON FORENSIC SCIENCE CENTER, INC:**

Position One - **ELLEN COHEN**, reappointment, for a term to expire 6/30/2027, and to serve as Chair

Position Three - **PHILIP H. HILDER**, reappointment, for a term to expire 6/30/2027

Position Five - **SONIA CORRALES**, appointment, for a term to expire 6/30/2027

Position Six - **JORN (CHI-CHUNG) YU**, appointment, for an unexpired term ending 6/30/2026

Position Seven - **ASMA H. MIRZA**, appointment, for a term to expire 6/30/2027

Position Nine - **VICKI HUFF**, reappointment, for a term to expire 6/30/2027

Background:

September 2024

The Honorable City Council
Houston, Texas

Dear Council Members:

The Houston Forensic Science Center, Inc., which does business as the Houston Forensic Science Center (HFSC), is a local government corporation created by Resolution No. 2012-17 "to operate an independent center providing the City with accurate and timely analysis of forensic evidence and related services." Subject to City Council confirmation, I am appointing or reappointment the following individuals to HFSC's Board of Directors, subject to City Council confirmation:

Ellen R. Cohen, appointment to Position One, for a term to expire June 30, 2027, and to serve as Chair;
Philip H. Hilder, reappointment to Position Three, for a term to expire June 30, 2027;
Sonia Corrales, appointment to Position Five, for a term to expire June 30, 2027;
Jorn (Chi-Chung) Yu, appointment to Position Six, for an unexpired term ending 2026;
Asma H. Mirza, appointment to Position Seven, for a term to expire June 30, 2027; and

Vicki Huff, reappointment to Position Nine, for a term to expire June 30, 2027.

The appointments will be effective on the date of City Council's confirmation.

The résumés of the nominees are attached for your review. Detailed information regarding HFSC is available at www.houstonforensicscience.org.

Sincerely,

John Whitmire
Mayor

ATTACHMENTS:

Description

Type



CITY OF HOUSTON - CITY COUNCIL

Meeting Date: 9/24/2024

District K

Item Creation Date: 6/17/2024

25GM369 – Accept Work – DNB Enterprises, Inc. –
Underground Storage Tank Removal, Remediation, and
Installation, Fire Station 82

Agenda Item#: 2.

Summary:

RECOMMENDATION from Director General Services Department for approval of final contract amount of \$354,982.39 and acceptance of work on contract with **DNB ENTERPRISES, INC** for Underground Storage Tank Removal (UST), Remediation and Installation at Fire Station 82 - 4.20% under the original contract amount - **DISTRICT K - CASTEX-TATUM**

Background:

RECOMMENDATION: The General Services Department recommends approval of the final contract amount of \$354,982.39 and acceptance of work on the contract with DNB Enterprises, Inc., for Underground Storage Tank Removal (UST), Remediation, and Installation at Fire Station 82 – 4.20% below the original contract amount - **DISTRICT K – MARTHA CASTEX-TATUM**

SPECIFIC EXPLANATION: On May 31, 2023, by Ordinance No. 2023-383 City Council awarded a construction contract to DNB Enterprises, Inc., for the Underground Storage Tank Removal, Remediation, and Installation at Fire Station 82. The General Services Department recommends that City Council approve the final contract amount of \$354,982.39 or 4.20% below the original contract amount, accept the work and authorize final payment to DNB Enterprises, Inc.

PROJECT LOCATION: 11250 Braesridge Dr., Houston, Texas 77071

PROJECT DESCRIPTION: The project removed and remediated one 1,000-gallon gasoline UST and one 1,000-gallon diesel UST, due to aging, and replaced with a 5,000-gallon, two-compartment UST, which consists of a 3,000-gallon gasoline compartment and a 2,000-gallon diesel compartment.

CONTRACT COMPLETION AND COST: The contractor completed the project within 115 days, 5 days less than the original contract time of 120 days. The project's final cost, including change orders, is \$354,982.39 a decrease of \$15,567.61 below the original contract amount.

M/W/SBE PARTICIPATION: No City M/WBE participation goal was established for this project as the contract amount does not exceed the threshold of \$1,000,000.00 required for goal-oriented contracts per Section 15-82 of the City Code of Ordinances.

PREVIOUS CHANGE ORDERS: The change orders relocated a 10-inch PVC drain line which would have interfered with the placement of the new UST and provided a credit to the City for

materials and work not required to complete the project.

WBS No: C-000003-0001-4-01-01

DIRECTOR'S SIGNATURE/DATE:

C. J. Messiah, Jr.
General Services Department

Thomas Munoz
Houston Fire Department

Prior Council Action:

Ordinance No. 2023-383; Dated May 31, 2023

Amount and Source of Funding:

No Additional Funding Required

Previous Funding:

\$ 422,605 – Fire Consolidated Construction Fund (4500)

Contact Information:

Enid M. Howard

Council Liaison

Phone: 832.393.8023

ATTACHMENTS:

Description

Coversheet

Vicinity Map

Site Map

Type

Signed Cover sheet

Backup Material

Backup Material



CITY OF HOUSTON - CITY COUNCIL

Meeting Date: 8/13/2024

District K

Item Creation Date: 6/17/2024

25GM369 – Accept Work – DNB Enterprises, Inc. – Underground Storage Tank Removal, Remediation, and Installation, Fire Station 82

Agenda Item#: 6.

Background:

RECOMMENDATION: The General Services Department recommends approval of the final contract amount of \$354,982.39 and acceptance of work on the contract with DNB Enterprises, Inc., for Underground Storage Tank Removal (UST), Remediation, and Installation at Fire Station 82 – 4.20% below the original contract amount - **DISTRICT K – MARTHA CASTEX-TATUM**

SPECIFIC EXPLANATION: On May 31, 2023, by Ordinance No. 2023-383 City Council awarded a construction contract to DNB Enterprises, Inc., for the Underground Storage Tank Removal, Remediation, and Installation at Fire Station 82. The General Services Department recommends that City Council approve the final contract amount of \$354,982.39 or 4.20% below the original contract amount, accept the work and authorize final payment to DNB Enterprises, Inc.

PROJECT LOCATION: 11250 Braesridge Dr., Houston, Texas 77071

PROJECT DESCRIPTION: The project removed and remediated one 1,000-gallon gasoline UST and one 1,000-gallon diesel UST, due to aging, and replaced with a 5,000-gallon, two-compartment UST, which consists of a 3,000-gallon gasoline compartment and a 2,000-gallon diesel compartment.

CONTRACT COMPLETION AND COST: The contractor completed the project within 115 days, 5 days less than the original contract time of 120 days. The project's final cost, including change orders, is \$354,982.39 a decrease of \$15,567.61 below the original contract amount.

M/W/SBE PARTICIPATION: No City M/WBE participation goal was established for this project as the contract amount does not exceed the threshold of \$1,000,000.00 required for goal-oriented contracts per Section 15-82 of the City Code of Ordinances.

PREVIOUS CHANGE ORDERS: The change orders relocated a 10-inch PVC drain line which would have interfered with the placement of the new UST and provided a credit to the City for materials and work not required to complete the project.

WBS No: C-000003-0001-4-01-01

DIRECTOR'S SIGNATURE/DATE:

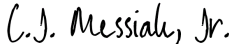
DocuSigned by:
 7/26/2024
C. J. MESSIAH, JR.
General Services Department

Samuel Peña
Houston Fire Department

Prior Council Action:
Ordinance No. 2023-383; Dated May 31, 2023

Amount and Source of Funding:
No Additional Funding Required

Previous Funding:
\$ 422,605 – Fire Consolidated Construction Fund (4500)

Contact Information:

Enid M. Howard
Council Liaison



Phone: 832.393.8023

ATTACHMENTS:

Description

[Vicinity Map](#)

[Site Map](#)

[Prior Council Action \(Ordinance & RCA\)](#)

[Change Order 1 & 2](#)

[OBO Closeout](#)

[Consent of Surety](#)

Type

Backup Material

Backup Material

Backup Material

Backup Material

Backup Material

Backup Material

CITY OF HOUSTON
HARRIS COUNTY, TEXAS

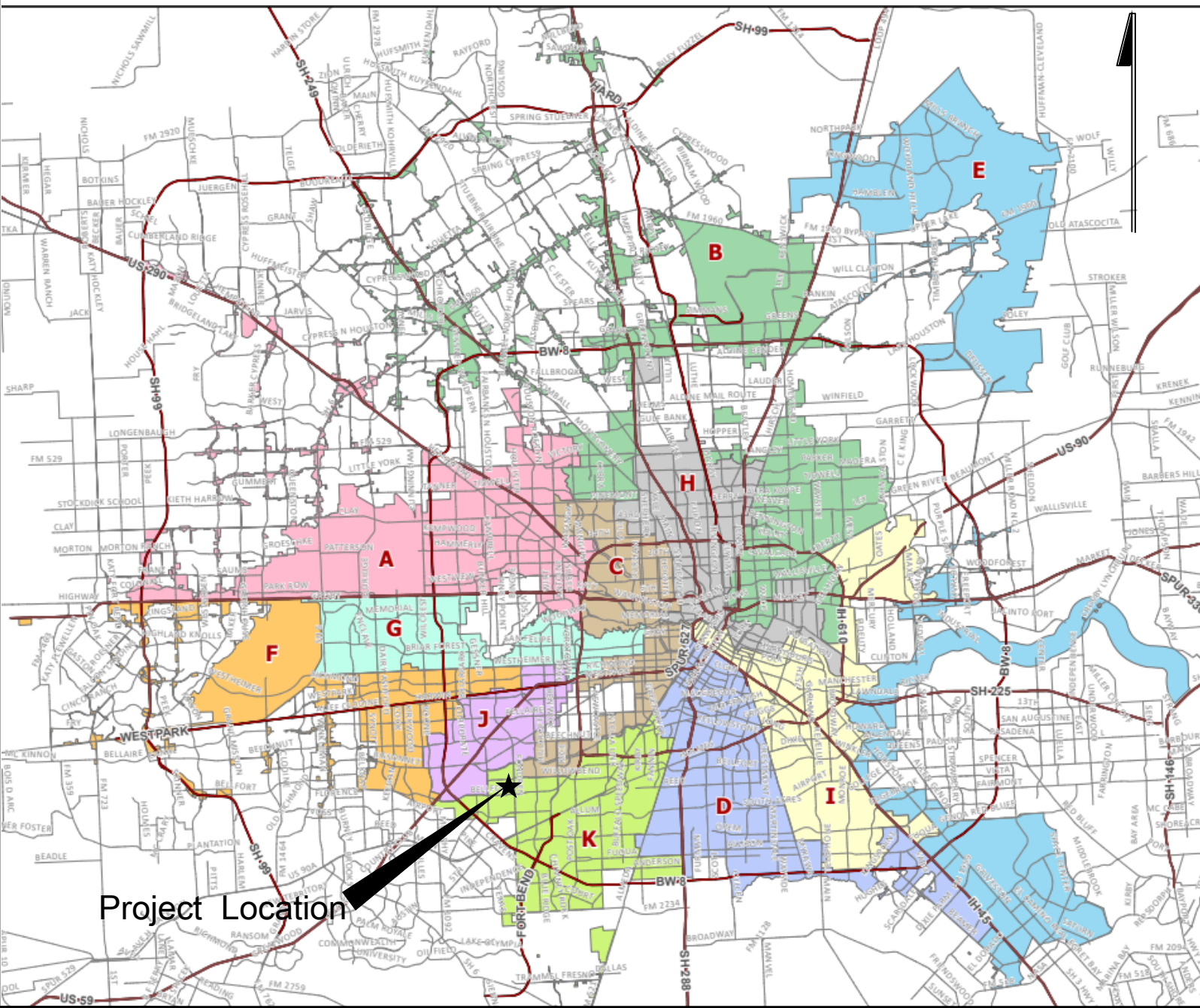

PROJECT: UNDERGROUND STORAGE TANK REMOVAL, REMEDIATION, AND
INSTALLATION
FIRE STATION 82
11250 BRAESRIDGE DR.
HOUSTON, TX 77071

COUNCIL DISTRICT "K"

KEY MAP NO. 570C

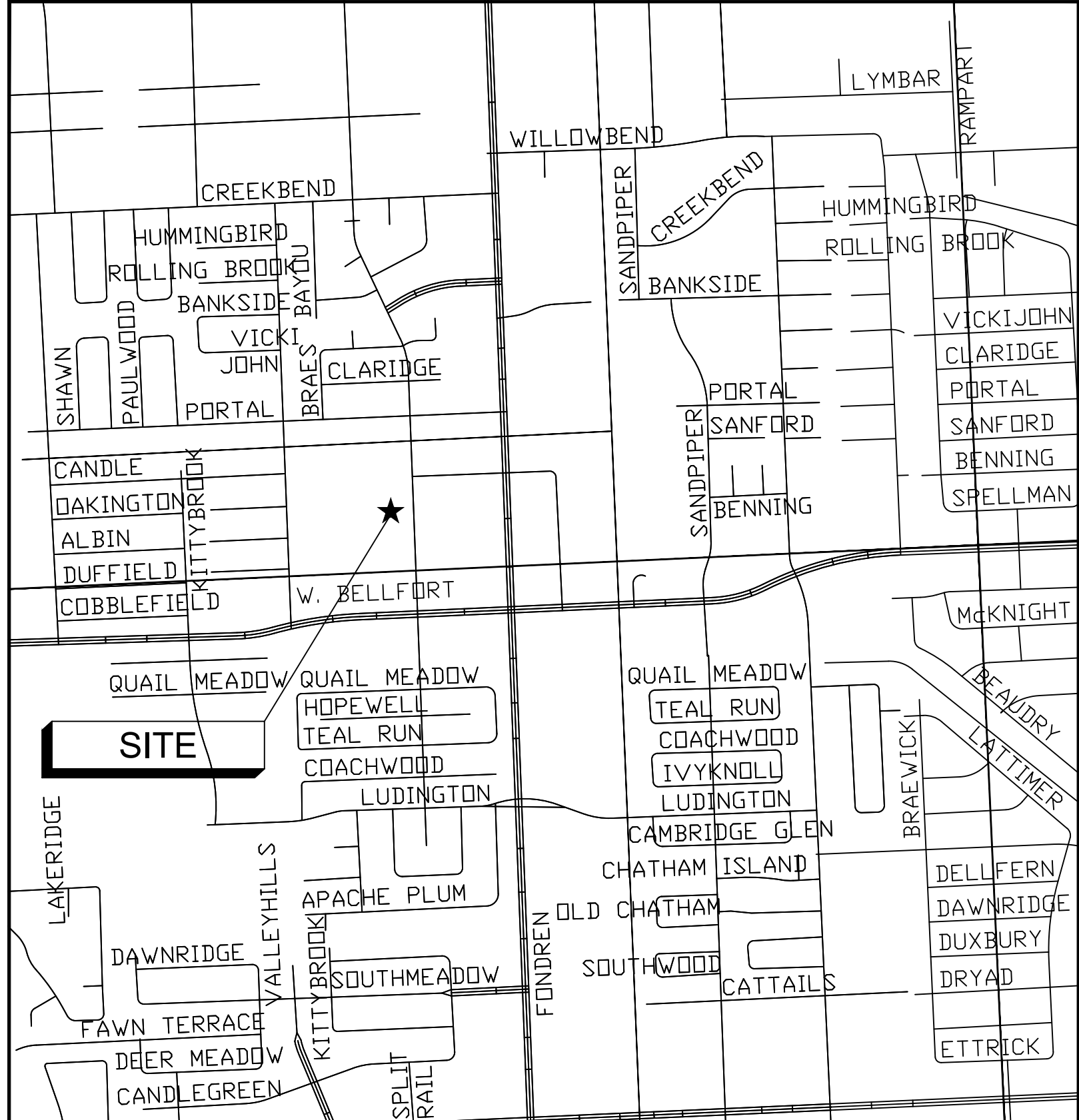

PROJECT: UNDERGROUND STORAGE TANK REMOVAL, REMEDIATION, AND
INSTALLATION
 FIRE STATION 82
 11250 BRAESRIDGE DR.
 HOUSTON, TX 77071



CITY OF HOUSTON - CITY COUNCIL

Meeting Date: 9/24/2024
District A, District D, District J
Item Creation Date: 8/19/2024

HPW – 20WWO1147 Accept Work / LEM Construction Company, Inc.

Agenda Item#: 3.

Summary:

RECOMMENDATION from Chief Operating Officer, Houston Public Works for approval of final contract amount of \$2,483,377.42 and acceptance of work on contract with **LEM CONSTRUCTION COMPANY, INC** for Keegans Bayou, Northwest and Chocolate Bayou Wastewater Treatment Plants (WWTP) Bar Screen and Grating Replacement - 4.88% under the original contract amount - **DISTRICTS A - PECK; D - EVANS-SHABAZZ and J - POLLARD**

Background:

SUBJECT: Accept Work for Keegans Bayou, Northwest and Chocolate Bayou Wastewater Treatment Plants (WWTP) Bar Screen and Grating Replacement.

RECOMMENDATION: (SUMMARY) Pass a motion to approve the final contract amount of \$2,483,377.42 or 4.88% under the original contract amount, accept the Work and authorize final payment.

PROJECT NOTICE/JUSTIFICATION: This project was part of the City's ongoing program to improve inefficient components of the existing wastewater treatment plant facilities.

DESCRIPTION/SCOPE: This project consisted of 1. Rehabilitation of the walkway grating and grating support system at the influent and effluent aeration basin channels at the Keegans Bayou WWTP; 2. Removal and replacement of the bar screens, conveyor system as well as associated electrical, control and ancillary equipment at the Keegans Bayou, Northwest and Chocolate Bayou WWTPs. HR Green Inc. designed the project with 270 calendar days allowed for construction. The project was awarded to LEM Construction Company, Inc. with an original contract amount of \$2,610,750.00.

LOCATION:

FACILITY NAME	LOCATION	COUNCIL DISTRICT
Northwest WWTP	5423 Mangum Road, 77091	A
Chocolate Bayou WWTP	9600 Martin Luther King Blvd, 77048	D
Keegans Bayou WWTP	9400 White Chapel Lane, 77074	J

CONTRACT COMPLETION AND COST: The contractor, LEM Construction Company, Inc., has completed the work under the subject contract. The project was completed beyond the established completion date with an additional 267 days approved by Change Order No 1, 2 and 3. The final cost of the project, including overrun and underrun of estimated unit price quantities and previously approved Change Order No. 1 is \$2,483,377.42, a decrease of \$127,372.58 or 4.88% under the original contract amount. The decreased cost is a result of the difference between planned and measured quantities.

M/WSBE PARTICIPATION: The advertised M/WBE contract goals for this project were 11% MBE, and 7% WBE. The M/WSBE goals approved for this project were 9.96% MBE, 7.22% WBE and 8.43% SBE. According to the Office of Business Opportunity, the actual participation achieved on this project was 10.62% MBE, 7.59% WBE and 8.86% SBE. The MWSBE performance on this project was rated Satisfactory for the following reasons: the MBE, WBE, and the SBE goals were met and all goal credit subcontractors were used to full capacity. For the reasons listed, the MWSBE performance meets the good faith efforts requirements mandated by the City's MWSBE Program.

Randall V. Macchi, Chief Operating Officer
Houston Public Works

WBS No. R-000265-144B-4

Prior Council Action:

Ordinance No. 2021-0087, dated 02-03-2021

Amount and Source of Funding:

No additional funding required.

Original appropriation of \$2,871,825.00 from Fund No. 8500 - Water and Sewer System Consolidated Construction Fund.

Contact Information:

Name	Service Line	Contact No.
Roberto Medina, Interim Chief of Staff	DO-HPW Government Relations	832.395.2456
Maria Perez, HPW Agenda Coordinator	DO-HPW Government Relations	832.395.2282
Joseph Majdalani, Senior Assistant Director	HPW Houston Water	832-395-8530

ATTACHMENTS:

Description

Signed Coversheet

Maps

Type

Signed Cover sheet

Backup Material



CITY OF HOUSTON - CITY COUNCIL

Meeting Date:
 District A, District D, District J
 Item Creation Date: 8/19/2024

HPW – 20WWO1147 Accept Work / LEM Construction Company, Inc.

Agenda Item#:

Background:

SUBJECT: Accept Work for Keegans Bayou, Northwest and Chocolate Bayou Wastewater Treatment Plants (WWTP) Bar Screen and Grating Replacement.

RECOMMENDATION: (SUMMARY) Pass a motion to approve the final contract amount of \$2,483,377.42 or 4.88% under the original contract amount, accept the Work and authorize final payment.

PROJECT NOTICE/JUSTIFICATION: This project was part of the City’s ongoing program to improve inefficient components of the existing wastewater treatment plant facilities.

DESCRIPTION/SCOPE: This project consisted of 1. Rehabilitation of the walkway grating and grating support system at the influent and effluent aeration basin channels at the Keegans Bayou WWTP; 2. Removal and replacement of the bar screens, conveyor system as well as associated electrical, control and ancillary equipment at the Keegans Bayou, Northwest and Chocolate Bayou WWTPs. HR Green Inc. designed the project with 270 calendar days allowed for construction. The project was awarded to LEM Construction Company, Inc. with an original contract amount of \$2,610,750.00.

LOCATION:

FACILITY NAME	LOCATION	COUNCIL DISTRICT
Northwest WWTP	5423 Mangum Road, 77091	A
Chocolate Bayou WWTP	9600 Martin Luther King Blvd, 77048	D
Keegans Bayou WWTP	9400 White Chapel Lane, 77074	J

CONTRACT COMPLETION AND COST: The contractor, LEM Construction Company, Inc., has completed the work under the subject contract. The project was completed beyond the established completion date with an additional 267 days approved by Change Order No 1, 2 and 3. The final cost of the project, including overrun and underrun of estimated unit price quantities and previously approved Change Order No. 1 is \$2,483,377.42, a decrease of \$127,372.58 or 4.88% under the original contract amount. The decreased cost is a result of the difference between planned and measured quantities.

M/WSBE PARTICIPATION: The advertised M/WBE contract goals for this project were 11% MBE, and 7% WBE. The M/WSBE goals approved for this project were 9.96% MBE, 7.22% WBE and 8.43% SBE. According to the Office of Business Opportunity, the actual participation achieved on this project was 10.62% MBE, 7.59% WBE and 8.86% SBE. The MWSBE performance on this project was rated Satisfactory for the following reasons: the MBE, WBE, and the SBE goals were met and all goal credit subcontractors were used to full capacity. For the reasons listed, the MWSBE performance meets the good faith efforts requirements mandated by the City’s MWSBE Program.

DocuSigned by:

 9/13/2024
 BE463EF0DF454EB...

Randall V. Macchi, Chief Operating Officer
 Houston Public Works

WBS No. R-000265-144B-4

Prior Council Action:

Ordinance No. 2021-0087, dated 02-03-2021

Amount and Source of Funding:

No additional funding required.

Original appropriation of \$2,871,825.00 from Fund No. 8500 - Water and Sewer System Consolidated Construction Fund.

Contact Information:

Name	Service Line	Contact No.
Roberto Medina, Interim Chief of Staff	DO-HPW Government Relations	832.395.2456
Maria Perez, HPW Agenda Coordinator	DO-HPW Government Relations	832.395.2282
Joseph Majdalani, Senior Assistant Director	HPW Houston Water	832-395-8530

ATTACHMENTS:

Description

Maps
 OBO Documents
 Prior Council Action
 Ownership Information Form & Tax Report
 Change Orders No. 1 to 3
 Final Estimate

Type

Backup Material
 Backup Material
 Backup Material
 Backup Material
 Backup Material
 Backup Material

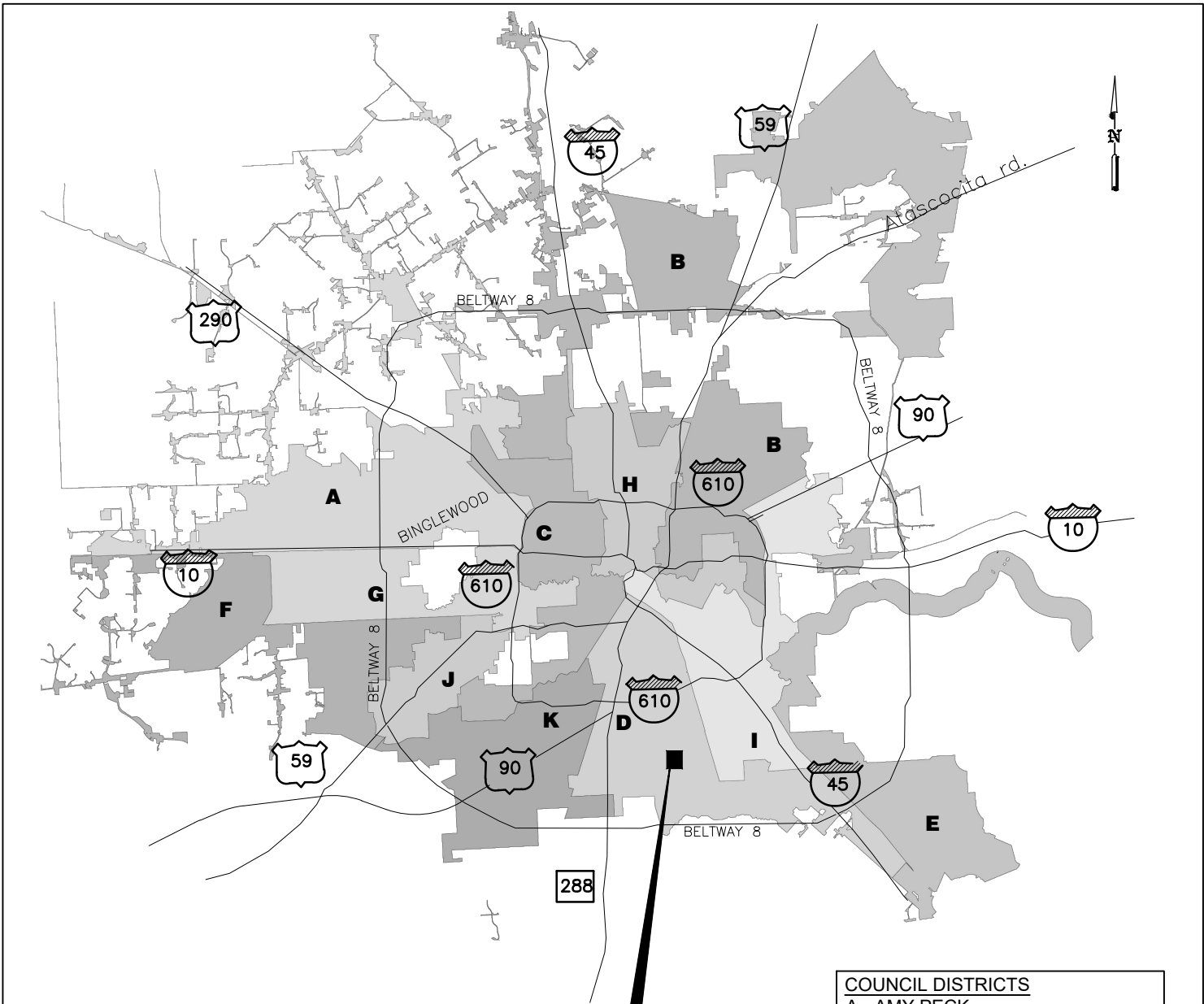

CHOCOLATE BAYOU WWTP
 KEY MAP NO. 574-E
 GIMS MAP NO. 5452-B
 COUNCIL DISTRICT D
 9600 MARTIN LUTHER KING BLVD
 HOUSTON, TX 77033

- COUNCIL DISTRICTS**
- A - AMY PECK
 - B - TARSHA JACKSON
 - C - ABBIE KAMIN
 - D - CAROLYN EVANS-SHABAZZ
 - E - FRED FLICKINGER
 - F - TIFFANY THOMAS
 - G - MARY NAN HUFFMAN
 - H - MARIO CASTILLO JR.
 - I - JOAQUIN MARTINEZ
 - J - EDWARD POLLARD
 - K - MARTHA CASTEX-TATUM
 - AT LARGE 1 - JULIAN RAMIREZ
 - AT LARGE 2 - WILLIE DAVIS
 - AT LARGE 3 - TWILA CARTER
 - AT LARGE 4 - LETITIA PLUMMER
 - AT LARGE 5 - SALLIE ALCORN

VICINITY MAP

GIMS MAP NO: 5452-B

	11011 RICHMOND AVE, SUITE 200 HOUSTON, TX 77042 (713) 965-9996 (713) 965-0044 FAX HRGreen.com Firm No. F-11278	
	DATE: APRIL 2020	SCALE: NTS
FILEPATH: \\hrgreen.com\HRG\Data\2015\85150029.09\CAD\Exhibits\LOCATION AND VICINITY MAPS - NW KB CB WWTPS\LOCATION & VIC MAP.dwg		

CITY OF HOUSTON
 HOUSTON PUBLIC WORKS
 KEEGANS BAYOU, NORTHWEST, AND
 CHOCOLATE BAYOU WWTPs BAR SCREEN AND
 GRATING REPLACEMENT
 WBS NO. R-000265-144B-4

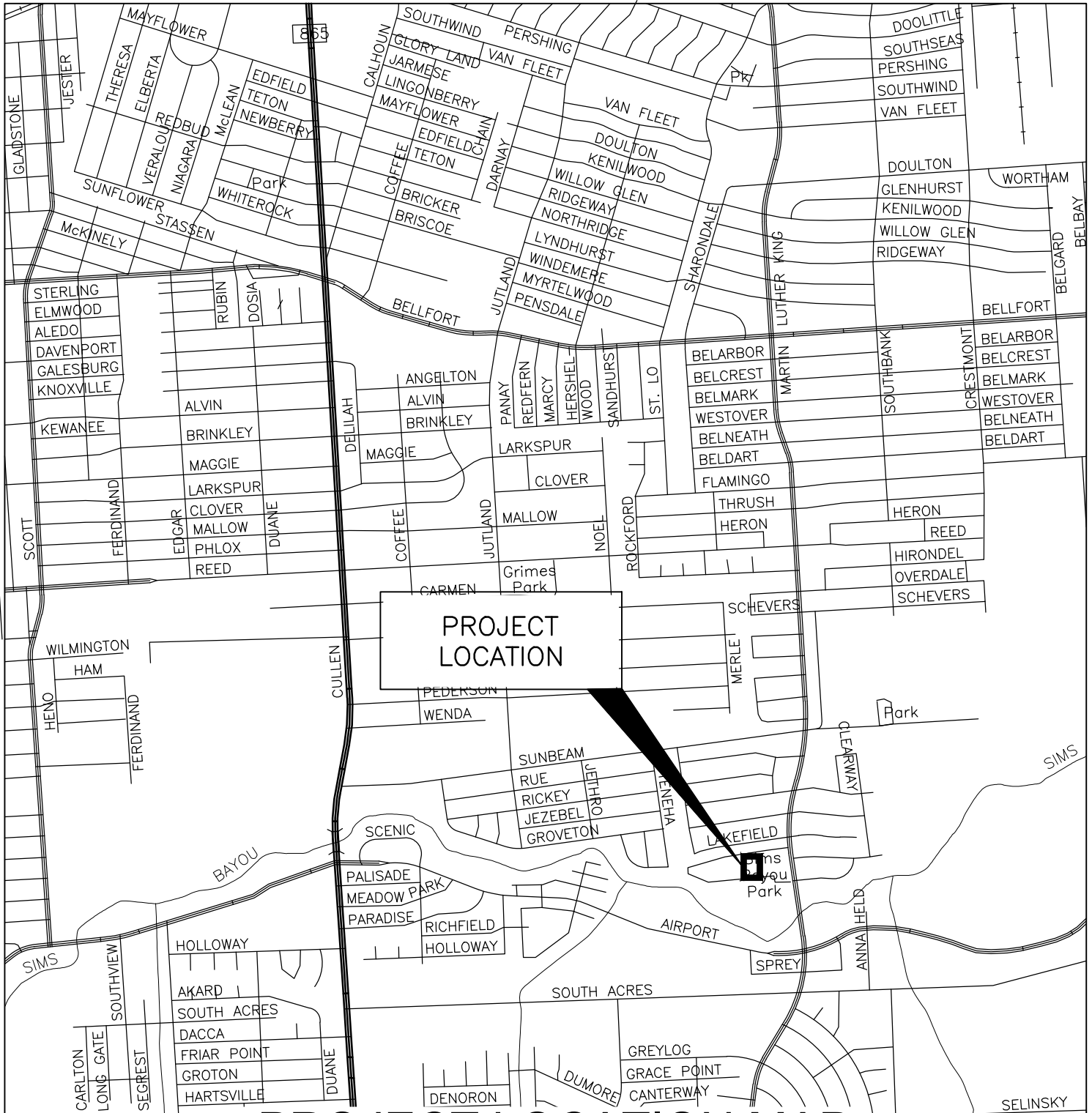

PROJECT
LOCATION

PROJECT LOCATION MAP

CHOCOLATE BAYOU WASTEWATER TREATMENT PLANT
GIMS MAP NO: 5452-B
COUNCIL DISTRICT D

HRGreen
11011 RICHMOND AVE, SUITE 200
HOUSTON, TX 77042
(713) 965-9996
(713) 965-0044 FAX
HRGreen.com
Firm No. F-11278

DATE: APRIL 2020	SCALE: NTS
FILEPATH: J:\2015\85150029.09\CAD\Exhibits\LOCATION AND VICINITY MAPS - NW KB CB WWTPS\LOCATION & VIC MAP.dwg	

CITY OF HOUSTON
HOUSTON PUBLIC WORKS
KEEGANS BAYOU, NORTHWEST, AND
CHOCOLATE BAYOU WWTPs BAR SCREEN AND
GRATING REPLACEMENT
WBS NO. R-000265-144B-4

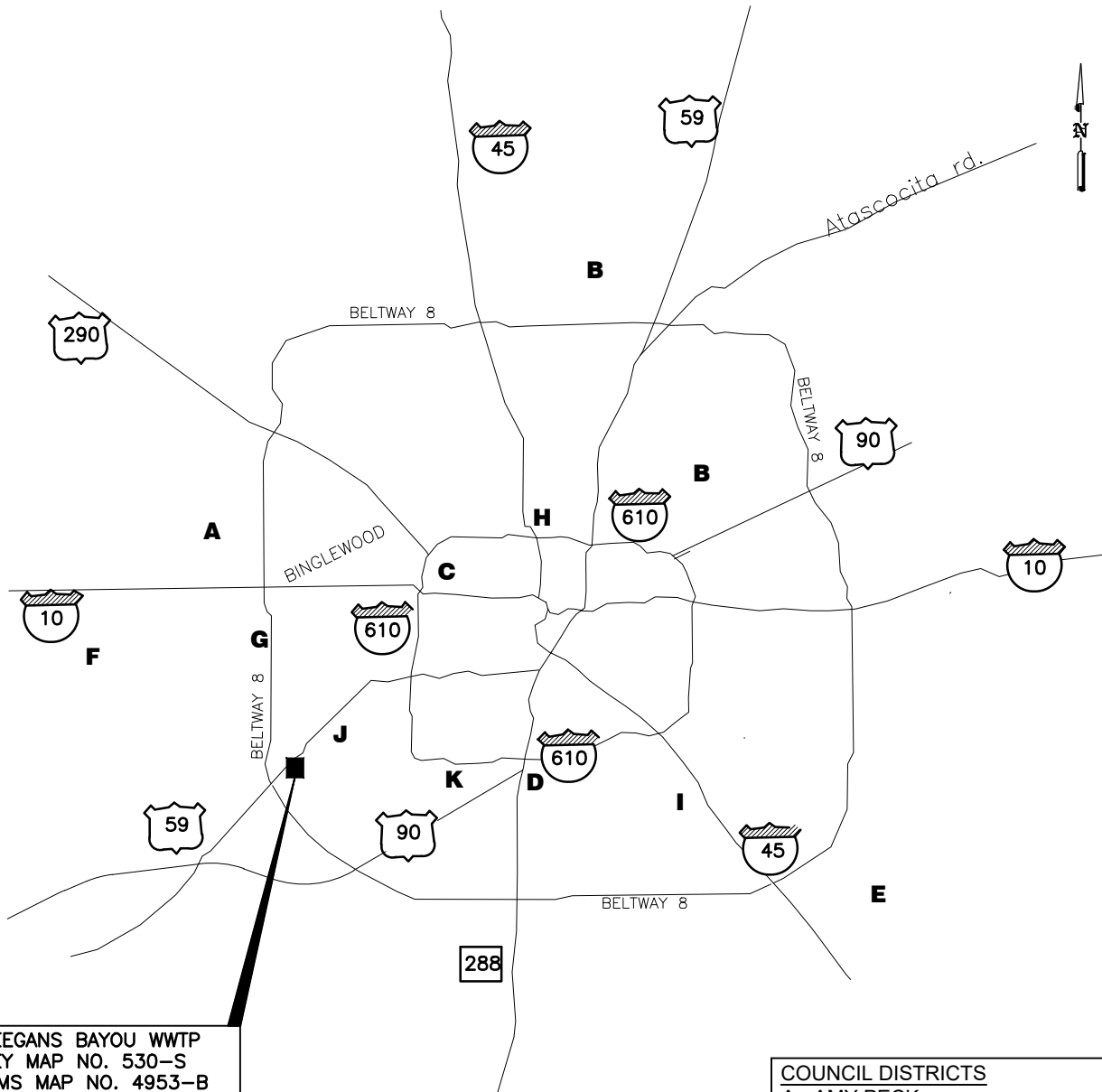

KEEGANS BAYOU WWTP
 KEY MAP NO. 530-S
 GIMS MAP NO. 4953-B
 COUNCIL DISTRICT J
 9401 WHITE CHAPEL LANE
 HOUSTON, TX 77072

- COUNCIL DISTRICTS**
- A - AMY PECK
 - B - TARSHA JACKSON
 - C - ABBIE KAMIN
 - D - CAROLYN EVANS-SHABAZZ
 - E - FRED FLICKINGER
 - F - TIFFANY THOMAS
 - G - MARY NAN HUFFMAN
 - H - MARIO CASTILLO JR.
 - I - JOAQUIN MARTINEZ
 - J - EDWARD POLLARD
 - K - MARTHA CASTEX-TATUM
 - AT LARGE 1 - JULIAN RAMIREZ
 - AT LARGE 2 - WILLIE DAVIS
 - AT LARGE 3 - TWILA CARTER
 - AT LARGE 4 - LETITIA PLUMMER
 - AT LARGE 5 - SALLIE ALCORN

VICINITY MAP

GIMS MAP NO: 4953-B



11011 RICHMOND AVE, SUITE 200
 HOUSTON, TX 77042
 (713) 965-9996
 (713) 965-0044 FAX
 HRGreen.com
 Firm No. F-11278

CITY OF HOUSTON

HOUSTON PUBLIC WORKS

KEEGANS BAYOU, NORTHWEST, AND
 CHOCOLATE BAYOU WWTPs BAR SCREEN AND
 GRATING REPLACEMENT
 WBS NO. R-000265-144B-4

DATE: APRIL 2020 SCALE: NTS

FILEPATH: \\hrgreen.com\HRG\Data\2015\85150029.09\CAD\Exhibits\LOCATION AND VICINITY MAPS - NW KB CB WWTPS\LOCATION & VIC MAP.dwg

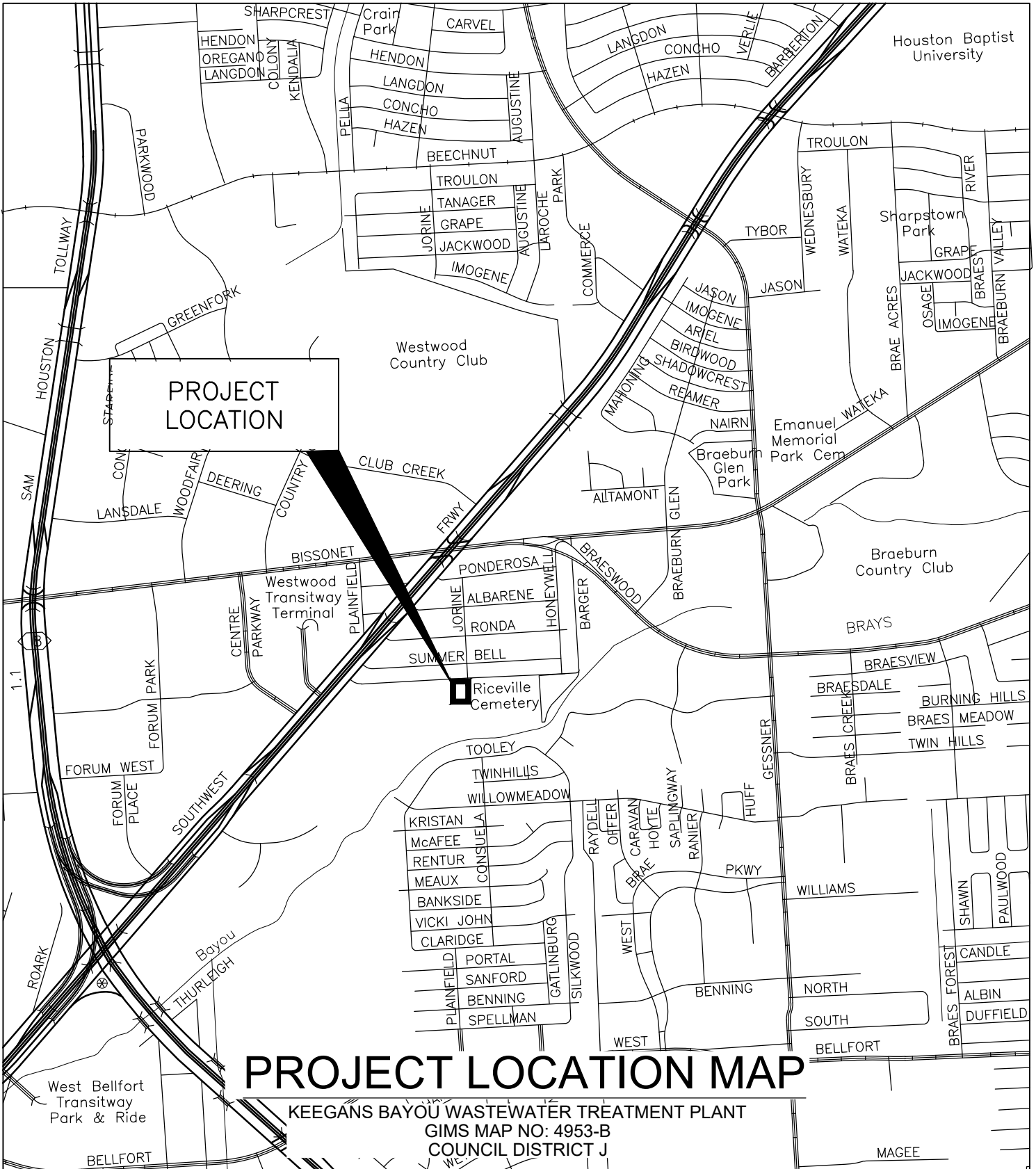

PROJECT LOCATION MAP

KEEGANS BAYOU WASTEWATER TREATMENT PLANT
 GIMS MAP NO: 4953-B
 COUNCIL DISTRICT J



11011 RICHMOND AVE, SUITE 200
 HOUSTON, TX 77042
 (713) 965-9996
 (713) 965-0044 FAX
 HRGreen.com
 Firm No. F-11278

CITY OF HOUSTON

HOUSTON PUBLIC WORKS

KEEGANS BAYOU, NORTHWEST, AND
 CHOCOLATE BAYOU WWTPs BAR SCREEN AND
 GRATING REPLACEMENT
 WBS NO. R-000265-144B-4

DATE: APRIL 2020 SCALE: NTS

FILEPATH: J:\2015\85150029.09\CAD\Exhibits\LOCATION AND VICINITY MAPS - NW KB CB WWTPS\LOCATION & VIC MAP.dwg

NORTHWEST WWTP
 KEY MAP NO. 451-C
 GIMS MAP NO. 5161-D
 COUNCIL DISTRICT A
 5423 MANGUM ROAD
 HOUSTON, TX 77091

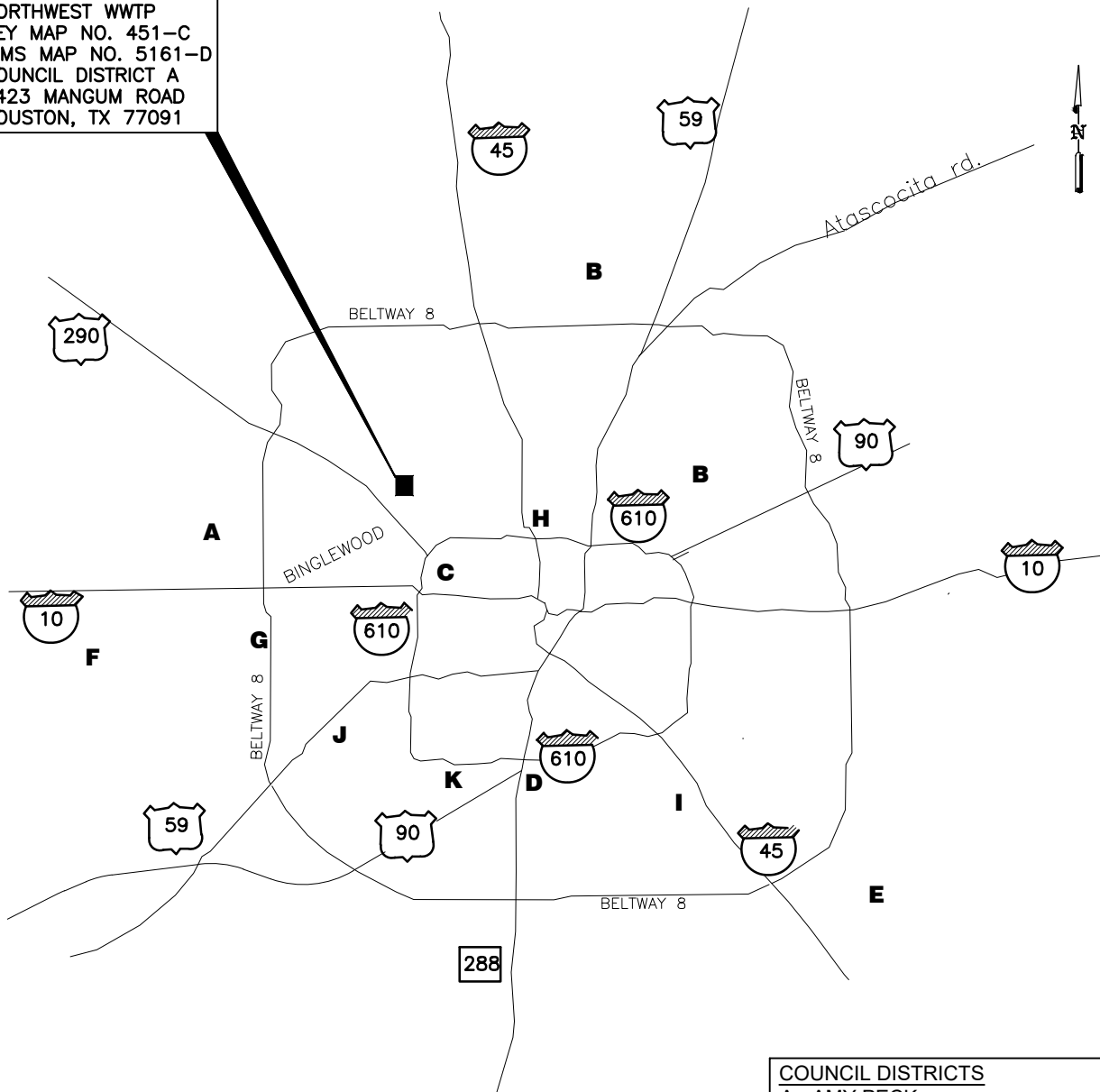

VICINITY MAP

GIMS MAP NO: 5161-D

- COUNCIL DISTRICTS**
- A - AMY PECK
 - B - TARSHA JACKSON
 - C - ABBIE KAMIN
 - D - CAROLYN EVANS-SHABAZZ
 - E - FRED FLICKINGER
 - F - TIFFANY THOMAS
 - G - MARY NAN HUFFMAN
 - H - MARIO CASTILLO JR.
 - I - JOAQUIN MARTINEZ
 - J - EDWARD POLLARD
 - K - MARTHA CASTEX-TATUM
 - AT LARGE 1 - JULIAN RAMIREZ
 - AT LARGE 2 - WILLIE DAVIS
 - AT LARGE 3 - TWILA CARTER
 - AT LARGE 4 - LETITIA PLUMMER
 - AT LARGE 5 - SALLIE ALCORN



11011 RICHMOND AVE, SUITE 200
 HOUSTON, TX 77042
 (713) 965-9996
 (713) 965-0044 FAX
 HRGreen.com
 Firm No. F-11278

DATE: APRIL 2020 SCALE: NTS

FILEPATH: \\hrgreen.com\HRG\Data\2015\85150029.09\CAD\Exhibits\LOCATION AND VICINITY MAPS - NW KB CB WWTPS\LOCATION & VIC MAP.dwg

CITY OF HOUSTON
 HOUSTON PUBLIC WORKS
 KEEGANS BAYOU, NORTHWEST, AND
 CHOCOLATE BAYOU WWTPs BAR SCREEN AND
 GRATING REPLACEMENT
 WBS NO. R-000265-144B-4

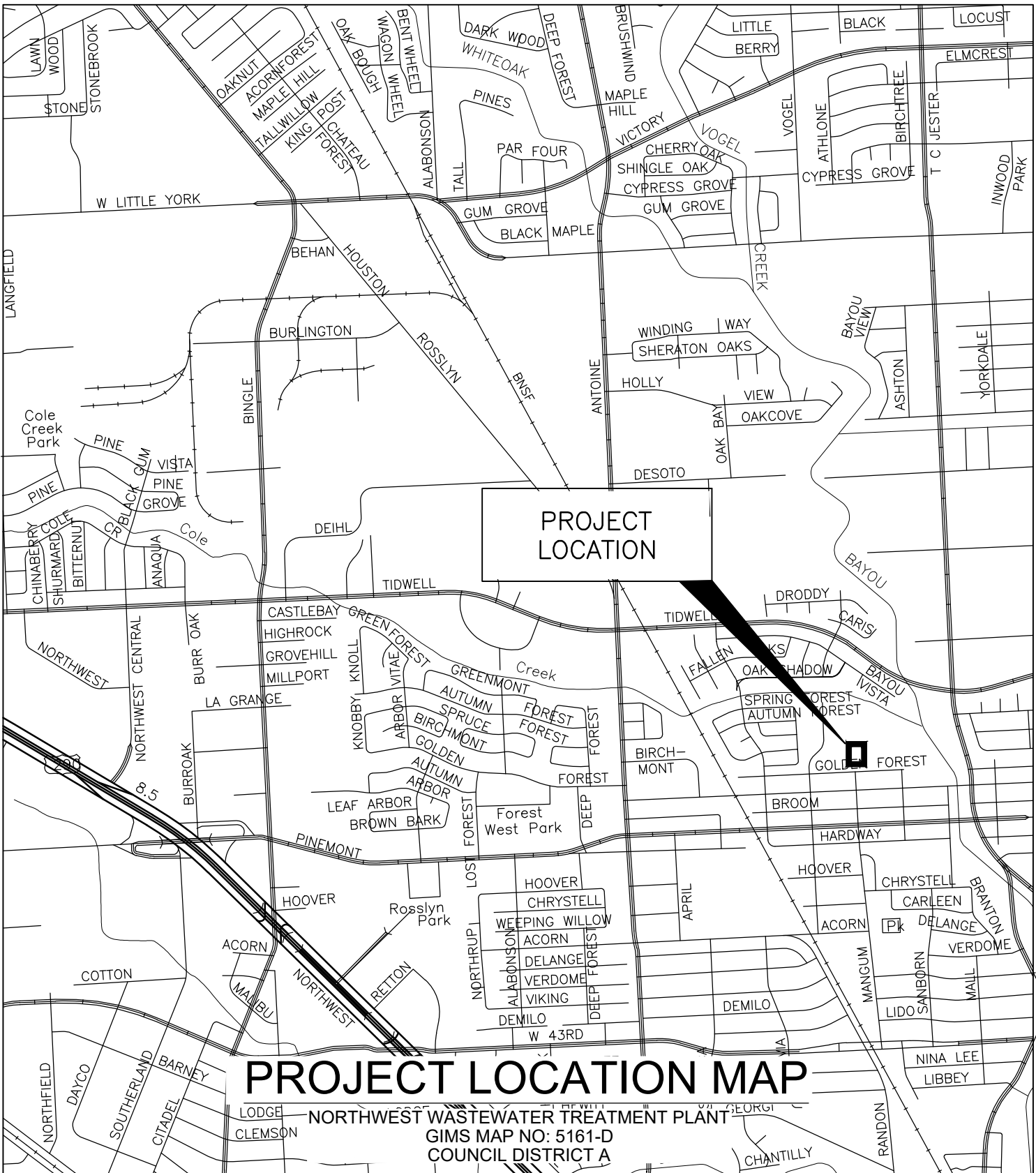

PROJECT LOCATION MAP

NORTHWEST WASTEWATER TREATMENT PLANT
 GIMS MAP NO: 5161-D
 COUNCIL DISTRICT A



11011 RICHMOND AVE, SUITE 200
 HOUSTON, TX 77042
 (713) 965-9996
 (713) 965-0044 FAX
 HRGreen.com
 Firm No. F-11278

CITY OF HOUSTON

HOUSTON PUBLIC WORKS

KEEGANS BAYOU, NORTHWEST, AND
 CHOCOLATE BAYOU WWTPs BAR SCREEN AND
 GRATING REPLACEMENT
 WBS NO. R-000265-144B-4

DATE: APRIL 2020 SCALE: NTS

FILEPATH: J:\2015\85150029.09\CAD\Exhibits\LOCATION AND VICINITY MAPS - NW KB CB WWTPS\LOCATION & VIC MAP.dwg



CITY OF HOUSTON - CITY COUNCIL

Meeting Date: 9/24/2024

District D

Item Creation Date:

LGL – Parcels KY23-290, KY23-291, KY23-292, TCY23-058, and TCY23-059; City of Houston v. Almeria Holdings LLC., et al.; Cause No. 1215685; 48-inch Waterline from 288 to Cullen Boulevard along East Orem Drive Project; WBS/CIP No. S-000900-0173-2

Agenda Item#: 4.

Summary:

RECOMMENDATION from the City Attorney in connection with eminent domain proceeding styled City of Houston v. Almeria Holdings LLC., et al.; Cause No.1215685, for the acquisition of Parcels KY23-290, KY23-291, KY23-292, TCY23-058 and TCY23-059 for the **48-INCH WATERLINE FROM 288 TO CULLEN BOULEVARD ALONG EAST OREM DRIVE PROJECT - DISTRICT D - EVANS-SHABAZZ**

Background:

The 48-Inch Waterline from 288 to Cullen Boulevard along East Orem Drive Project is a part of the City’s regionalization program in compliance with the Harris-Galveston Subsidence District requirement to implement the City’s long range water supply plan. The Project will provide for the design, construction, use, maintenance and operation of transmission and distribution lines to convey treated water from surface water facilities in accordance with the Project plans.

This eminent domain proceeding involves the acquisition of easement interest in three parcels of land containing 33,990 square feet plus the acquisition of two temporary construction easements containing 2119 square feet. The properties are located on Scott Street in the City of Houston. The properties are owned by Almeria Holdings, LLC. Prior to sending the matter to the Legal Department, the City attempted to negotiate a purchase of the properties, but those efforts were unsuccessful. The matter was then referred to the Legal Department to initiate eminent domain proceedings to acquire the needed properties. The Legal Department filed the eminent domain petition and a Special Commissioners’ hearing was held.

City’s Appraised Value:\$135,505.00

Defendant’s Appraised Value:\$464,586.00

Award of the Special Commissioners’ Hearing.\$173,237.50

(KY23-290: \$6,261.00, KY23-291: \$99,132.19, KY23-292: \$66,175.31, TCY23-058: \$835.00 & TCY23-059: \$834.00)

Court & Misc. Costs: Special Commissioners' fees: \$1,500.00 (\$500.00 x 3), Process Service: \$88.00, Court Filings: \$350.00, **Estimated Total Court & Misc. Costs:** \$1,938.00.

Arturo G. Michel, City Attorney

Randall V. Macchi
Chief Operating Officer, Houston Public Works

Prior Council Action:

Ordinance No. 2018-756, passed 9/19/18; Ordinance No. 2023-868 passed 10/18/2023.

Amount and Source of Funding:

\$173,237.50

Funds previously appropriated under Ordinance No. 2018-756 out of the Water and Sewer System Consolidation Construction Fund 8500.

Contact Information:

Steven Beard832-393-6295
Suzanne Chauvin..... 832-393-6219

ATTACHMENTS:

Description

Cover Sheet

Type

Signed Cover sheet



CITY OF HOUSTON - CITY COUNCIL

Meeting Date:

District D

Item Creation Date:

LGL – Parcels KY23-290, KY23-291, KY23-292, TCY23-058, and TCY23-059; City of Houston v. Almeria Holdings LLC., et al.; Cause No. 1215685; 48-inch Waterline from 288 to Cullen Boulevard along East Orem Drive Project; WBS/CIP No. S-000900-0173-2

Agenda Item#:

Summary:

Authorize the City Attorney, by Motion, to deposit the amount of the Award of the Special Commissioners of \$173,237.50 into the registry of the court and pay all costs. Funding will be provided by a previously approved blanket appropriation ordinance.

Background:

The 48-Inch Waterline from 288 to Cullen Boulevard along East Orem Drive Project is a part of the City's regionalization program in compliance with the Harris-Galveston Subsidence District requirement to implement the City's long range water supply plan. The Project will provide for the design, construction, use, maintenance and operation of transmission and distribution lines to convey treated water from surface water facilities in accordance with the Project plans.

This eminent domain proceeding involves the acquisition of easement interest in three parcels of land containing 33,990 square feet plus the acquisition of two temporary construction easements containing 2119 square feet. The properties are located on Scott Street in the City of Houston. The properties are owned by Almeria Holdings, LLC. Prior to sending the matter to the Legal Department, the City attempted to negotiate a purchase of the properties, but those efforts were unsuccessful. The matter was then referred to the Legal Department to initiate eminent domain proceedings to acquire the needed properties. The Legal Department filed the eminent domain petition and a Special Commissioners' hearing was held.

City's Appraised Value:\$135,505.00

Defendant's Appraised Value:\$464,586.00

Award of the Special Commissioners' Hearing.\$173,237.50

(KY23-290: \$6,261.00, KY23-291: \$99,132.19, KY23-292: \$66,175.31, TCY23-058: \$835.00 & TCY23-059: \$834.00)

Court & Misc. Costs: Special Commissioners' fees: \$1,500.00 (\$500.00 x 3), Process Service: \$88.00, Court Filings: \$350.00, **Estimated Total Court & Misc. Costs:** \$1,938.00.

DocuSigned by:

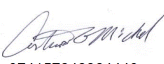
074157848964440
Arturo G. Michel, City Attorney

DocuSigned by:

9/10/2024
BE463EF0DF454EB...
Randall V. Macchi
Chief Operating Officer, Houston Public Works

Prior Council Action:

Ordinance No. 2018-756, passed 9/19/18; Ordinance No. 2023-868 passed 10/18/2023.

Amount and Source of Funding:

\$173,237.50; Funds previously appropriated under Ordinance No. 2018-756 out of the Water and Sewer System Consolidation Construction Fund 8500.

Contact Information:

Steven Beard832-393-6295
Suzanne Chauvin..... 832-393-6219



CITY OF HOUSTON - CITY COUNCIL

Meeting Date: 9/24/2024

Item Creation Date: 8/14/2024

WS1228927598 - Rubber Removal Services (Hi-Lite
Airfield Services, LLC.) - MOTION

Agenda Item#: 5.

Summary:

HI-LITE AIRFIELD SERVICES, LLC. for Emergency Purchase of Rubber Removal Services for the Houston Airport System - \$426,259.68 - Enterprise Fund

Background:

Emergency Purchase Order (P33- WS1228927598) - Approve final payment in the amount not to exceed \$426,259.68 to Hi-Lite Airfield Services, LLC. for the purchase of rubber removal services for the Houston Airport Systems.

Specific Explanation:

The Director of the Houston Airport Systems and the Chief Procurement Officer recommend that City Council approve final payment in the amount not to exceed **\$426,259.68** to **Hi-Lite Airfield Services, LLC** for the purchase of rubber removal services performed at Bush Intercontinental Airport (IAH) and Hobby Airport (HOU).

The Chief Procurement Officer issued an emergency purchase order to Hi-Lite Airfield Services, LLC. on March 28th, 2024, for rubber removal services performed at IAH and HOU airports. The rubber removal services were vital to the continued operations of the runways, as the rubber build-up had caused safety concerns that required cautionary "notice to air emissions" (NOTAM) to be provided to pilots before landing, and caused modified flight schedules, impacting the National Airspace System scheduling nationwide. Final invoice has been submitted by the contractor and vetted by HAS for payment.

Supplier Secretary of State Filing Date	Supplier City Registration Date
December 30, 2013	February 4, 2014

This recommendation is made pursuant to Chapter 252, Section 252.022 (a) (2) of the Texas Local Government Code for exempted procurements, which provides "a procurement necessary to preserve or protect the public health or safety of the municipality's residents."

MWBE Participation:

This procurement is exempt from the MWBE subcontracting participation goal because the department is utilizing an emergency purchase order for this purchase.

Hire Houston First:

This procurement is exempt from the City's Hire Houston First Ordinance. Bids/proposals were not solicited because the department is utilizing an emergency purchase order for this purchase.

Fiscal Note:

Funding for this item is included in the FY2025 Adopted Budget. Therefore, no Fiscal Note is required as stated in the Financial Policies.

Jedediah Greenfield, Chief Procurement Officer
Authority
Finance/Strategic Procurement Division

Department Approving

Estimated Spending Authority:

Department	FY2025	Out Years	Total
Houston Airport Systems	\$426,259.68	\$0.00	\$426,259.68

Amount and Source of Funding:

\$426,259.68
HAS Revenue
Fund 8001

Contact Information:

<u>Name</u>	<u>Dept/Division</u>	<u>Phone No.:</u>
Kody Allred, Senior Staff Analyst	Finance/SPD	(832) 393-8730
Yesenia Chuca, Deputy Assistant Director	Finance/SPD	(832) 393-8727
Candice Gambrell, Assistant Director	Finance/SPD	(832) 393-9129
Jedediah Greenfield, Chief Procurement Officer	Finance/SPD	(832) 393-9126

ATTACHMENTS:

Description
Coversheet

Type
Signed Cover sheet



CITY OF HOUSTON - CITY COUNCIL

Meeting Date: 9/24/2024

Item Creation Date: 8/14/2024

WS1228927598 - Rubber Removal Services (Hi-Lite Airfield Services, LLC.) - MOTION

Agenda Item#: 19.

Background:

Emergency Purchase Order (P33- WS1228927598) - Approve final payment in the amount not to exceed \$426,259.68 to Hi-Lite Airfield Services, LLC. for the purchase of rubber removal services for the Houston Airport Systems.

Specific Explanation:

The Director of the Houston Airport Systems and the Chief Procurement Officer recommend that City Council approve final payment in the amount not to exceed **\$426,259.68** to **Hi-Lite Airfield Services, LLC** for the purchase of rubber removal services performed at Bush Intercontinental Airport (IAH) and Hobby Airport (HOU).

The Chief Procurement Officer issued an emergency purchase order to Hi-Lite Airfield Services, LLC. on March 28th, 2024, for rubber removal services performed at IAH and HOU airports. The rubber removal services were vital to the continued operations of the runways, as the rubber build-up had caused safety concerns that required cautionary "notice to air emissions" (NOTAM) to be provided to pilots before landing, and caused modified flight schedules, impacting the National Airspace System scheduling nationwide. Final invoice has been submitted by the contractor and vetted by HAS for payment.

Supplier Secretary of State Filing Date	Supplier City Registration Date
December 30, 2013	February 4, 2014

This recommendation is made pursuant to Chapter 252, Section 252.022 (a) (2) of the Texas Local Government Code for exempted procurements, which provides "a procurement necessary to preserve or protect the public health or safety of the municipality's residents."

MWBE Participation:

This procurement is exempt from the MWBE subcontracting participation goal because the department is utilizing an emergency purchase order for this purchase.

Hire Houston First:

This procurement is exempt from the City's Hire Houston First Ordinance. Bids/proposals were not solicited because the department is utilizing an emergency purchase order for this purchase.

Fiscal Note:

Funding for this item is included in the FY2025 Adopted Budget. Therefore, no Fiscal Note is required as stated in the Financial Policies.

9/16/2024

DocuSigned by:

 6121834A077C41A...

Jedediah Greenfield, Chief Procurement Officer
Finance/Strategic Procurement Division

Department Approving Authority

Estimated Spending Authority:			
Department	FY2025	Out Years	Total
Houston Airport Systems	\$426,259.68	\$0.00	\$426,259.68

Amount and Source of Funding:

\$426,259.68 – HAS Revenue (Fund 8001)

Contact Information:

Name	Dept/Division	Phone No.:
Kody Allred, Senior Staff Analyst	Finance/SPD	(832) 393-8730
Yesenia Chuca, Deputy Assistant Director	Finance/SPD	(832) 393-8727

Candice Gambrell, Assistant Director	Finance/SPD	(832) 393-9129
Jedediah Greenfield, Chief Procurement Officer	Finance/SPD	(832) 393-9126

ATTACHMENTS:

Description

Certification of Funds
Fiscal Form A
Justification Form
Final Invoices

Type

Financial Information
Financial Information
Backup Material
Backup Material



CITY OF HOUSTON - CITY COUNCIL

Meeting Date: 9/24/2024

ALL

Item Creation Date: 8/21/2024

WS1180997929 - ShopKey software license renewals
(Snap-On Industrial) - MOTION

Agenda Item#: 6.

Summary:

APPROVE spending authority in the amount not to exceed \$692,094.26 for ShopKey Software License Renewal for the Fleet Management Department from the Cooperative Sourcewell **SNAP-ON INDUSTRIAL, a division of IDSC HOLDINGS, LLC** - 5 Years - Fleet Management Fund

Background:

WS1180997929 - Approve spending authority in the amount not to exceed \$692,094.26 for ShopKey software license renewals from Snap-On Industrial, a division of IDSC Holdings, LLC through the cooperative Sourcewell for ShopKey software license renewals for five (5) years for the Fleet Management Department.

Specific Explanation:

The Director of the Fleet Management Department (FMD) and the Chief Procurement Officer recommend that the City Council approve spending authority in an amount not to exceed **\$692,094.26** or **five (5) years** to Snap-On Industrial, a division of IDSC Holdings, LLC through the cooperative Sourcewell for ShopKey software license renewals for FMD.

The scope of work requires the contractor to provide the software license renewals for ShopKey Pro (Mitchell 1) software for FMD. The software provides FMD and the City of Houston's vehicle maintenance repair facilities with shop manuals, wiring diagrams, diagnostic tools, and Original Equipment Manufacturer (OEM) factory-sourced service information. The software also provides FMD's service technicians with Technical Service Bulletins (TSBs) and recommended vehicle repair procedures. TSBs are a form of diagnosis and are not to be confused with recalls; a TSB is issued by a vehicle manufacturer when there are several occurrences of an unanticipated problem. The ShopKey Pro software provides repair information tools for FMD's service technicians to develop an accurate diagnosis for an efficient and faster repair.

Snap-on Industrial/Mitchell 1 is the proprietary owner, developer, manufacturer, supplier, and distributor of the ShopKey Pro software application; there are no authorized third-party providers.

This recommendation is made pursuant to subsection 252.022(a)(7) of the Texas Local Government Code, which provides that "a procurement of items that are available from only one source" is exempt from the competitive requirements for purchases.

M/WBE Participation:

The zero-percentage goal document was approved by the Office of Business Opportunity.

Hire Houston First:

This procurement is exempt from the City’s Hire Houston First Ordinance. Bids/proposals were not solicited because the department utilizes a Cooperative Purchasing Agreement for this purchase.

Fiscal Note:

Funding for this item is included in the FY25 Adopted Budget. Therefore, no Fiscal Note is required as stated in the Financial Policies.

Jedediah Greenfield, Chief Procurement Officer
Finance/Strategic Procurement Division

Department Approval Authority Signature

Estimated Spending Authority			
DEPARTMENT	FY2025	OUT YEARS	TOTAL
Fleet Management Department	\$121,538.63	\$570,555.63	\$692,094.26

Amount and Source of Funding:

\$692,094.26
Fleet Management Fund
Fund 1005

Contact Information:

Adeola Otukoya, Division Manager	832-393-8729
Candice Gambrell, Assistant Director	832-393-9126
Jedediah Greenfield, Chief Procurement Officer	832-393-9129

ATTACHMENTS:

Description	Type
Coversheet	Signed Cover sheet



CITY OF HOUSTON - CITY COUNCIL

Meeting Date: 9/24/2024

ALL

Item Creation Date: 8/21/2024

WS1180997929 - ShopKey software license renewals (Snap-On Industrial) - MOTION

Agenda Item#:

Background:

WS1180997929 - Approve spending authority in the amount not to exceed \$692,094.26 for ShopKey software license renewals from Snap-On Industrial, a division of IDSC Holdings, LLC through the cooperative Sourcwell for ShopKey software license renewals for five (5) years for the Fleet Management Department.

Specific Explanation:

The Director of the Fleet Management Department (FMD) and the Chief Procurement Officer recommend that the City Council approve spending authority in an amount not to exceed **\$692,094.26** or **five (5) years** to Snap-On Industrial, a division of IDSC Holdings, LLC through the cooperative Sourcwell for ShopKey software license renewals for FMD.

The scope of work requires the contractor to provide the software license renewals for ShopKey Pro (Mitchell 1) software for FMD. The software provides FMD and the City of Houston's vehicle maintenance repair facilities with shop manuals, wiring diagrams, diagnostic tools, and Original Equipment Manufacturer (OEM) factory-sourced service information. The software also provides FMD's service technicians with Technical Service Bulletins (TSBs) and recommended vehicle repair procedures. TSBs are a form of diagnosis and are not to be confused with recalls; a TSB is issued by a vehicle manufacturer when there are several occurrences of an unanticipated problem. The ShopKey Pro software provides repair information tools for FMD's service technicians to develop an accurate diagnosis for an efficient and faster repair.

Snap-on Industrial/Mitchell 1 is the proprietary owner, developer, manufacturer, supplier, and distributor of the ShopKey Pro software application; there are no authorized third-party providers.

This recommendation is made pursuant to subsection 252.022(a)(7) of the Texas Local Government Code, which provides that "a procurement of items that are available from only one source" is exempt from the competitive requirements for purchases.

M/WBE Participation:

The zero-percentage goal document was approved by the Office of Business Opportunity.

Hire Houston First:

This procurement is exempt from the City's Hire Houston First Ordinance. Bids/proposals were not solicited because the department utilizes a Cooperative Purchasing Agreement for this purchase.

Fiscal Note:

Funding for this item is included in the FY25 Adopted Budget. Therefore, no Fiscal Note is required as stated in the Financial Policies.

9/16/2024

DocuSigned by:

 6121834A077C41A...

Jedediah Greenfield, Chief Procurement Officer
 Finance/Strategic Procurement Division

DocuSigned by:

 6CBC87A954AE4B1...

Department Approval Authority Signature

9/17/2024

Estimated Spending Authority			
DEPARTMENT	FY2025	OUT YEARS	TOTAL
Fleet Management Department	\$121,538.63	\$570,555.63	\$692,094.26

Amount and Source of Funding:

\$692,094.26 - Fleet Management Fund (1005)

Contact Information:

Adeola Otukoya, Division Manager	832-393-8729
Candice Gambrell, Assistant Director	832-393-9126
Jedediah Greenfield, Chief Procurement Officer	832-393-9129

ATTACHMENTS:

Description

Quote
Certification of Fund (COF)
Form A
Conflict of Interest Questionnaire
Tax Delinquent Report
Co-Op Request
Co-Op Request Approval
MWBE Goal Waiver
SnapOn Contract

Type

Backup Material
Financial Information
Financial Information
Backup Material
Backup Material
Backup Material
Backup Material
Backup Material
Backup Material



CITY OF HOUSTON - CITY COUNCIL

Meeting Date: 9/24/2024

ALL

Item Creation Date:

WS1098160340 - Petersen and New Way Replacement
Parts and Repair Services (Texas Packer and Loader Sales,
Inc.) - MOTION

Agenda Item#: 7.

Summary:

APPROVE spending authority in the amount not to exceed \$6,089,838.90 for Purchase of Petersen and New Way Replacement Parts and Repair Services from **TEXAS PACKER AND LOADER SALES, INC dba TEXAS PACK + LOAD** for the Fleet Management Department - 3 Years with 2 one-year options - Fleet Management Fund

Background:

Sole Source (S91-WS1098160340) - Approve spending authority in the amount not to exceed \$6,089,838.90 for the purchase of Petersen and New Way replacement parts and repair services from Texas Packer and Loader Sales, Inc. dba Texas Pack + Load for a period of 36-months with two one-year options for the Fleet Management Department.

Specific Explanation:

The Director of the Fleet Management Department and the Chief Procurement Officer recommend that City Council approve spending authority in the amount not to exceed **\$6,089,838.90** for the purchase of Petersen and New Way replacement parts and repair services from **Texas Packer and Loader Sales, Inc. dba Texas Pack+ Load** for the Fleet Management Department for a period of **36-months with two one-year options**. This award consists of a price list for various Petersen and New Way replacement parts, including but not limited to trash buckets, rollers, outriggers, torque arm assemblies, body doors, load covers, filter breathers, filter elements, and valve bodies. The department will use these materials to repair Petersen and New Way equipment citywide. This award also includes a **\$1,179,000.00** labor component for the repair of equipment that cannot be performed by City maintenance personnel.

Texas Packer and Loader Sales, Inc. dba Texas Pack+ Load is the sole distributor and service provider for the entire State of Texas for Petersen and New Way replacement parts and equipment.

This recommendation is made pursuant to subsection 252.022 (a)(7) of the Texas Local Government Code, which provides that "a procurement of items that are available from only one source is exempt from the competitive requirement for purchases".

M/WBE:

Zero percentage goal document approved by the Office of Business Opportunity.

Hire Houston First:

The procurement is exempt from the City's Hire Houston First Ordinance. Bids/proposals were not solicited because the department is utilizing a sole source vendor for this purchase.

Fiscal Note:

Funding for this item is included in the FY2025 Adopted Budget. Therefore, no fiscal note is required as stated in the Financial Policies.

Jedediah Greenfield
Chief Procurement Officer

Department Approval Authority

Estimated Spending Authority			
Department	FY2025	Out-Years	Award Amount
Fleet Management	\$1,191,767.78	\$4,898,071.12	\$6,089,838.90

Amount and Source of Funding:

\$6,089,838.90

Fleet Management Fund

Fund No.: 1005

Contact Information:

Desiree Heath	SPD	832-393-8742
Candice Gambrell	SPD	832-393-9129
Jedediah Greenfield	SPD	832-393-9126

ATTACHMENTS:

Description

Coversheet

Type

Signed Cover sheet



CITY OF HOUSTON - CITY COUNCIL

Meeting Date: 9/24/2024

ALL

Item Creation Date:

WS1098160340 - Petersen and New Way Replacement Parts and Repair Services (Texas Packer and Loader Sales, Inc.) - MOTION

Agenda Item#: 14.

Background:

Sole Source (S91-WS1098160340) - Approve spending authority in the amount not to exceed \$6,089,838.90 for the purchase of Petersen and New Way replacement parts and repair services from Texas Packer and Loader Sales, Inc. dba Texas Pack + Load for a period of 36-months with two one-year options for the Fleet Management Department.

Specific Explanation:

The Director of the Fleet Management Department and the Chief Procurement Officer recommend that City Council approve spending authority in the amount not to exceed **\$6,089,838.90** for the purchase of Petersen and New Way replacement parts and repair services from **Texas Packer and Loader Sales, Inc. dba Texas Pack+ Load** for the Fleet Management Department for a period of **36-months with two one-year options**. This award consists of a price list for various Petersen and New Way replacement parts, including but not limited to trash buckets, rollers, outriggers, torque arm assemblies, body doors, load covers, filter breathers, filter elements, and valve bodies. The department will use these materials to repair Petersen and New Way equipment citywide. This award also includes a **\$1,179,000.00** labor component for the repair of equipment that cannot be performed by City maintenance personnel.

Texas Packer and Loader Sales, Inc. dba Texas Pack+ Load is the sole distributor and service provider for the entire State of Texas for Petersen and New Way replacement parts and equipment.

This recommendation is made pursuant to subsection 252.022 (a)(7) of the Texas Local Government Code, which provides that "a procurement of items that are available from only one source is exempt from the competitive requirement for purchases".

M/WBE:

Zero percentage goal document approved by the Office of Business Opportunity.

Hire Houston First:

The procurement is exempt from the City's Hire Houston First Ordinance. Bids/proposals were not solicited because the department is utilizing a sole source vendor for this purchase.

Fiscal Note:

Funding for this item is included in the FY2025 Adopted Budget. Therefore, no fiscal note is required as stated in the Financial Policies.

9/16/2024

DocuSigned by:

6121834A077C41A...

Jedediah Greenfield
Chief Procurement Officer

DocuSigned by:

6CBC87A954AE4B1...

Department Approval Authority

9/17/2024

Estimated Spending Authority			
Department	FY2025	Out-Years	Award Amount
Fleet Management	\$1,191,767.78	\$4,898,071.12	\$6,089,838.90

Amount and Source of Funding:

\$6,089,838.90

Fleet Management Fund

Fund No.: 1005

Contact Information:

Desiree Heath	SPD	832-393-8742
Candice Gambrell	SPD	832-393-9129
Jedediah Greenfield	SPD	832-393-9126

ATTACHMENTS:

Description

WS108160340 - MWBE- 0% Goal Waiver Approval
WS108160340 - Bid Tabulation
WS108160340 - Sole Source Justification
WS108160340 - Sole Source Approval
WS108160340 - Ownership Information
WS108160340 - Tax Report
WS108160340 - Form A
WS108160340 - Conflict of Interest Questionnaire
Funding Verification -Fleet

Type

Backup Material
Backup Material
Backup Material
Backup Material
Backup Material
Backup Material
Financial Information
Backup Material
Financial Information



CITY OF HOUSTON - CITY COUNCIL

Meeting Date: 9/24/2024

ALL

Item Creation Date: 9/11/2024

WS1225288472 - Fuel Delivery Services (Sun Coast Resources, LLC.)- MOTION

Agenda Item#: 8.

Summary:

APPROVE spending authority in an amount not to exceed \$100,000.00 for Emergency Purchase and Delivery of Fuel for the Fleet Management Department from **SUN COAST RESOURCES, LLC** - Fleet Management Fund

Background:

Emergency Purchase Order (P33-WS1225288472) - Approve spending authority in an amount not to exceed \$100,000.00 for the purchase and delivery of fuel from Sun Coast Resources, LLC. for the Fleet Management Department.

Specific Explanation:

The Director of the Fleet Management Department and the Chief Procurement Officer recommend that the City Council approve spending authority in an amount not to exceed **\$100,000.00**, for the purchase and delivery of fuel from **Sun Coast Resources, LLC.**

This request is for a pre-positioned emergency purchase order to ensure continuity of services in the event of an emergency. The Strategic Procurement Division (SPD) will work with the Fleet Management Department (FMD) to create a pre-positioned multi-year contract for such services in the coming months.

Supplier Secretary of State Filing Date	Supplier City Registration Date
March 10, 2023	June 23, 2006

This recommendation is made pursuant to Chapter 252, Section 252.022 (a) (2) of the Texas Local Government Code for exempted procurements, which provides "a procurement necessary to preserve or protect the public health or safety of the municipality's residents."

MWBE Participation:

This procurement is exempt from the MWBE subcontracting participation goal because the department is utilizing an emergency purchase order for this purchase.

Hire Houston First:

This procurement is exempt from the City's Hire Houston First Ordinance. Bids/proposals were not solicited because the department is utilizing an emergency purchase order for this purchase.

Fiscal Note:

Funding for this item is included in the FY2025 Adopted Budget. Therefore, no Fiscal Note is required as stated in the Financial Policy.

Jedediah Greenfield, Chief Procurement Officer
Finance/Strategic Procurement Division

Department Approval Authority

Estimated Spending Authority:

Department	FY2025	Out Years	Total
Fleet Management Department	\$100,000.00	\$0.00	\$100,000.00

Amount and Source of Funding:

\$100,000.00 - Fleet Management Fund (1005)

Contact Information:

Name	Dept/Division	Phone No.:
Kody Allred, Senior Staff Analyst	Finance/SPD	(832) 393-8730
Yesenia Chuca, Deputy Assistant Director	Finance/SPD	(832) 393-8727
Candice Gambrell, Assistant Director	Finance/SPD	(832) 393-9129
Jedediah Greenfield, Chief Procurement Officer	Finance/SPD	(832) 393-9126

ATTACHMENTS:

Description

Coversheet

Type

Signed Cover sheet



CITY OF HOUSTON - CITY COUNCIL

Meeting Date: 9/24/2024

ALL

Item Creation Date: 9/11/2024

WS1225288472 - Fuel Delivery Services (Sun Coast Resources, LLC.)- MOTION

Agenda Item#: 15.

Background:

Emergency Purchase Order (P33-WS1225288472) - Approve spending authority in an amount not to exceed \$100,000.00 for the purchase and delivery of fuel from Sun Coast Resources, LLC. for the Fleet Management Department.

Specific Explanation:

The Director of the Fleet Management Department and the Chief Procurement Officer recommend that the City Council approve spending authority in an amount not to exceed **\$100,000.00**, for the purchase and delivery of fuel from **Sun Coast Resources, LLC.**

This request is for a pre-positioned emergency purchase order to ensure continuity of services in the event of an emergency. The Strategic Procurement Division (SPD) will work with the Fleet Management Department (FMD) to create a pre-positioned multi-year contract for such services in the coming months.

Supplier Secretary of State Filing Date	Supplier City Registration Date
March 10, 2023	June 23, 2006

This recommendation is made pursuant to Chapter 252, Section 252.022 (a) (2) of the Texas Local Government Code for exempted procurements, which provides "a procurement necessary to preserve or protect the public health or safety of the municipality's residents."

MWBE Participation:

This procurement is exempt from the MWBE subcontracting participation goal because the department is utilizing an emergency purchase order for this purchase.

Hire Houston First:

This procurement is exempt from the City's Hire Houston First Ordinance. Bids/proposals were not solicited because the department is utilizing an emergency purchase order for this purchase.

Fiscal Note:

Funding for this item is included in the FY2025 Adopted Budget. Therefore, no Fiscal Note is required as stated in the Financial Policy.

9/16/2024

Proposed by

 6121834A077C41A...

Approved by

 6CBC87A954AE4B1...

Jedediah Greenfield, Chief Procurement Officer
 Finance/Strategic Procurement Division

Department Approval Authority

9/17/2024

Estimated Spending Authority:			
Department	FY2025	Out Years	Total
Fleet Management Department	\$100,000.00	\$0.00	\$100,000.00

Amount and Source of Funding:

\$100,000.00 - Fleet Management Fund (1005)

Contact Information:

Name	Dept/Division	Phone No.:
Kody Allred, Senior Staff Analyst	Finance/SPD	(832) 393-8730
Yesenia Chuca, Deputy Assistant Director	Finance/SPD	(832) 393-8727
Candice Gambrell, Assistant Director	Finance/SPD	(832) 393-9129
Jedediah Greenfield, Chief Procurement Officer	Finance/SPD	(832) 393-9126

ATTACHMENTS:

Description

Justification Form
CPO Email Approval
Fiscal Form A
Funding Verification -Fleet

Type

Backup Material
Backup Material
Financial Information
Financial Information



CITY OF HOUSTON - CITY COUNCIL

Meeting Date: 9/24/2024

ALL

Item Creation Date:

Doc1144344098 - McNeilus Refuse Body Replacement
Parts and Repair Services (Siddons Martin Emergency
Group, LLC) - MOTION

Agenda Item#: 9.

Summary:

SIDDONS MARTIN EMERGENCY GROUP, LLC for McNeilus Refuse Body Replacement Parts and Repair Services for the Fleet Management Department - 3 Years with 2 one-year options - \$8,332,362.70 - Fleet Management Fund

Background:

Formal Bid Received July 25, 2024, for P26-Doc1144344098 - Approve an award to Siddons Martin Emergency Group, LLC in an amount not to exceed \$8,332,362.70 for McNeilus refuse body replacement parts and repair services for a thirty-six (36) month period with two one-year options for the Fleet Management Department.

Specific Explanation:

The Director of the Fleet Management Department (FMD) and the Chief Procurement Officer recommend that City Council approve an award to **Siddons Martin Emergency Group, LLC** on its sole bid in an amount not to exceed **\$8,332,362.70** for McNeilus refuse body replacement parts and repair services for a **thirty-six (36) month period with two one-year options** for the Fleet Management Department.

This award consists of a price list for various McNeilus refuse truck and body replacement parts which includes but are not limited to cylinders, valves, filters, bumpers, door rails, door panel protectors, seat axles, retrofit kits, idler arms, switches, joystick handles, and coils. The Fleet Management Department will use these materials to repair and maintain McNeilus refuse truck bodies citywide. This award also includes a **\$3,858,950.00** labor component for repair services that cannot be performed by City personnel.

This project was advertised in accordance with the requirements of the State of Texas bid laws. Two prospective bidders downloaded the solicitation document from the SAP Business Network Discovery (Ariba) website, and one bid was received.

- Subsequent to receipt of the bid, the Strategic Procurement Division contacted potential bidders to determine the reason for the limited response to the ITB. Potential bidders stated that they were not in the core business of providing these services.

MWBE Subcontracting:

The bid was issued a 6% M/WBE participation goal. Siddons Martin Emergency Group, LLC submitted a Pre-Award Good Faith Effort to the Office of Business opportunity, which was approved at 0%. Therefore, Siddons Martin Emergency Group, LLC will not be required to meet the 6% M/WBE participation goal.

Hire Houston First:

The proposed award requires compliance with the City’s ‘Hire Houston First’ (HHF) ordinance that promotes economic opportunity for Houston businesses and supports job creation. In this case, Siddons Martin Emergency Group, LLC is a designated HHF company, but they were the successful awardee without application of the HHF preference.

Fiscal Note:

Funding for this item is included in the FY2025 Adopted Budget. Therefore, no Fiscal Note is required as stated in the Financial Policies.

Jedediah Greenfield / Chief Procurement Officer
Signature
Finance/Strategic Procurement Division

Department Approval Authority

Estimated Spending Authority

Department	FY2025	Out Years	Total
Fleet Management	\$1,544,682.54	\$6,787,680.16	\$8,332,362.70

Amount and Source of Funding:

\$8,332,362.70
Fleet Management Fund
Fund No.: 1005

Contact Information:

Desiree Heath	SPD	832-393-8742
Candice Gambrell	SPD	832-393-9129
Jedediah Greenfield	SPD	832-393-9126

ATTACHMENTS:

Description	Type
Coversheet	Signed Cover sheet



CITY OF HOUSTON - CITY COUNCIL

Meeting Date: 9/24/2024

ALL

Item Creation Date:

Doc1144344098 - McNeilus Refuse Body Replacement Parts and Repair Services
(Siddons Martin Emergency Group, LLC) - MOTION

Agenda Item#: 16.

Background:

Formal Bid Received July 25, 2024, for P26-Doc1144344098 - Approve an award to Siddons Martin Emergency Group, LLC in an amount not to exceed \$8,332,362.70 for McNeilus refuse body replacement parts and repair services for a thirty-six (36) month period with two one-year options for the Fleet Management Department.

Specific Explanation:

The Director of the Fleet Management Department (FMD) and the Chief Procurement Officer recommend that City Council approve an award to **Siddons Martin Emergency Group, LLC** on its sole bid in an amount not to exceed **\$8,332,362.70** for McNeilus refuse body replacement parts and repair services for a **thirty-six (36) month period with two one-year options** for the Fleet Management Department.

This award consists of a price list for various McNeilus refuse truck and body replacement parts which includes but are not limited to cylinders, valves, filters, bumpers, door rails, door panel protectors, seat axles, retrofit kits, idler arms, switches, joystick handles, and coils. The Fleet Management Department will use these materials to repair and maintain McNeilus refuse truck bodies citywide. This award also includes a **\$3,858,950.00** labor component for repair services that cannot be performed by City personnel.

This project was advertised in accordance with the requirements of the State of Texas bid laws. Two prospective bidders downloaded the solicitation document from the SAP Business Network Discovery (Ariba) website, and one bid was received.

- Subsequent to receipt of the bid, the Strategic Procurement Division contacted potential bidders to determine the reason for the limited response to the ITB. Potential bidders stated that they were not in the core business of providing these services.

MWBE Subcontracting:

The bid was issued a 6% M/WBE participation goal. Siddons Martin Emergency Group, LLC submitted a Pre-Award Good Faith Effort to the Office of Business opportunity, which was approved at 0%. Therefore, Siddons Martin Emergency Group, LLC will not be required to meet the 6% M/WBE participation goal.

Hire Houston First:

The proposed award requires compliance with the City's 'Hire Houston First' (HHF) ordinance that promotes economic opportunity for Houston businesses and supports job creation. In this case, Siddons Martin Emergency Group, LLC is a designated HHF company, but they were the successful awardee without application of the HHF preference.

Fiscal Note:

Funding for this item is included in the FY2025 Adopted Budget. Therefore, no Fiscal Note is required as stated in the Financial Policies.

9/16/2024

DocuSigned by:

6121834A077C41A...

Jedediah Greenfield / Chief Procurement Officer
Finance/Strategic Procurement Division

DocuSigned by:

6CBC87A954AE4B1...

Department Approval Authority Signature

9/17/2024

Estimated Spending Authority

Department	FY2025	Out Years	Total
Fleet Management	\$1,544,682.54	\$6,787,680.16	\$8,332,362.70

Amount and Source of Funding:

\$8,332,362.70
Fleet Management Fund
Fund No.: 1005

Contact Information:

Desiree Heath	SPD	832-393-8742
Candice Gambrell	SPD	832-393-9129
Jedediah Greenfield	SPD	832-393-9126

ATTACHMENTS:

Description

MWBE GFE Waiver
Bid Tab
Ownership Form
Tax Delinquent Report
Form A
Certification of Funds
Conflict of Interest

Type

Backup Material
Backup Material
Backup Material
Backup Material
Financial Information
Financial Information
Backup Material



CITY OF HOUSTON - CITY COUNCIL

Meeting Date: 9/24/2024

ALL

Item Creation Date:

WS1186331660 - Ford Maverick Hybrids (Silsbee Ford) -
MOTION

Agenda Item#: 10.

Summary:

SILSBEE FORD for Purchase of Ford Maverick Hybrid Trucks through The Interlocal Purchasing System (TIPS) for the Fleet Management Department on behalf of the Houston Police Department - \$90,857.25 - Equipment Acquisition Consolidated Fund

Background:

S80-WS1186331660 - Approve the purchase of Ford Maverick Hybrid trucks through The Interlocal Purchasing System (TIPS) in the total amount of \$90,857.25 for the Fleet Management Department on behalf of the Houston Police Department.

Specific Explanation:

The Director of Fleet Management and the Chief Procurement Officer recommend that City Council approve the purchase of three (3) Ford Maverick Hybrid trucks from **Silsbee Ford** through The Interlocal Purchasing System (TIPS) in the amount of **\$90,857.25** for the Houston Police Department. These vehicles will be used by Department personnel to provide services to the citizens throughout the City.

These vehicles of the proposed Ford Maverick package have been vetted and approved by the Fleet Management Department.

The life expectancy of these vehicles is seven years or 100,000 miles. These new vehicles will meet the EPA's current emission standards for low emission vehicles. These vehicles will replace existing vehicles that have reached their life expectancy and will be sent to auction for disposal. This recommendation is made pursuant to subsection 271.102(c) of the Texas Local Government Code, which provides that "a local government that purchases goods or services from a cooperative purchasing program or organization satisfies any state law requiring the local government to seek competitive bids for the purchase of the goods or services."

M/WBE Participation:

Zero-percent goal document approved by the Office of Business Opportunity.

Hire Houston First:

This procurement is exempt from the City's Hire Houston First Ordinance. Bids/proposals were not solicited because the department is utilizing an Interlocal or Cooperative Purchasing

Agreement for this purchase.

Fiscal Note:

Funding for this item is included in the FY2025 Adopted Budget. Therefore, no Fiscal Note is required as stated in the Financial Policies

Jedediah Greenfield, Chief Procurement Officer
Finance/Strategic Procurement Division

Department Approval Authority

Estimated Spending Authority			
Department	FY25	Out Years	Total
Houston Police Department	\$90,857.25	\$0	\$90,857.25

Amount and Source of Funding:

\$90,857.25
Auto Dealers Fund
Fund 2200

Contact Information:

Name	Dept/Division	Phone No.:	
Lena Farris, Division Manager	Finance /SPD	(832) 393-8729	
Candice Gambrell, Assistant Director	Finance/SPD	(832) 393-9129	
Jedediah Greenfield, Chief Procurement Officer	Finance/SPD	(832) 393-9126	

ATTACHMENTS:

Description

Coversheet

Type

Signed Cover sheet



CITY OF HOUSTON - CITY COUNCIL

Meeting Date: 9/24/2024

ALL

Item Creation Date:

WS1186331660 - Ford Maverick Hybrids (Silsbee Ford) - MOTION

Agenda Item#: 20.

Summary:

NOT A REAL CAPTION

SILSBEE FORD for the purchase of Fort Maverick Hybrid trucks through the Interlocal Purchasing Systems for the Fleet Management Department on behalf of the Houston Police Department - \$90,857.25 - Equipment Acquisition Consolidated Fund

Background:

S80-WS1186331660 - Approve the purchase of Ford Maverick Hybrid trucks through The Interlocal Purchasing System (TIPS) in the total amount of \$90,857.25 for the Fleet Management Department on behalf of the Houston Police Department.

Specific Explanation:

The Director of Fleet Management and the Chief Procurement Officer recommend that City Council approve the purchase of three (3) Ford Maverick Hybrid trucks from **Silsbee Ford** through The Interlocal Purchasing System (TIPS) in the amount of **\$90,857.25** for the Houston Police Department. These vehicles will be used by Department personnel to provide services to the citizens throughout the City. The funding for these vehicles is included in the FY2025 Capital Improvement Plan.

These vehicles of the proposed Ford Maverick package have been vetted and approved by the Fleet Management Department.

The life expectancy of these vehicles is seven years or 100,000 miles. These new vehicles will meet the EPA's current emission standards for low emission vehicles. These vehicles will replace existing vehicles that have reached their life expectancy and will be sent to auction for disposal.

This recommendation is made pursuant to subsection 271.102(c) of the Texas Local Government Code, which provides that "a local government that purchases goods or services from a cooperative purchasing program or organization satisfies any state law requiring the local government to seek competitive bids for the purchase of the goods or services."

M/WBE Participation:

Zero-percent goal document approved by the Office of Business Opportunity.

Hire Houston First:

This procurement is exempt from the City's Hire Houston First Ordinance. Bids/proposals were not solicited because the department is utilizing an Interlocal or Cooperative Purchasing Agreement for this purchase.

Fiscal Note:

No significant Fiscal Operating impact is anticipated as a result of this project.

9/16/2024

DocuSigned by:

6121834A077C41A...

Jedediah Greenfield, Chief Procurement Officer
Finance/Strategic Procurement Division

DocuSigned by:

6CBC87A954AE4B1...

Department Approval Authority

9/17/2024

Estimated Spending Authority			
Department	FY25	Out Years	Total
Houston Police Department	\$90,857.25	\$0	\$90,857.25

Prior Council Action:

Appropriation Ordinance 2024-0592 approved by City Council August 14, 2024

Amount and Source of Funding:

\$90,857.25
Equipment Acquisition Consolidated Fund
Fund 1800 - **Previously appropriated by Ord.#2024-0592**

Contact Information:

Name	Dept./Division	Phone Number
------	----------------	--------------

Name	Dept/DIVISION	Phone No.:
Lena Farris, Division Manager	Finance /SPD	(832) 393-8729
Candice Gambrell, Assistant Director	Finance/SPD	(832) 393-9129
Jedediah Greenfield, Chief Procurement Officer	Finance/SPD	(832) 393-9126

ATTACHMENTS:

Description

Fiscal Form A for HPD
OBO Waiver
Delinquent Tax Report Silsbee Ford
Affidavit of Ownership - Silsbee Ford
Quote - Silsbee Ford
Co-Op Justification Form
Previous Appropriation 2024-0592

Type

Financial Information
Backup Material
Backup Material
Backup Material
Financial Information
Backup Material
Backup Material



CITY OF HOUSTON - CITY COUNCIL

Meeting Date: 9/24/2024

ALL

Item Creation Date: 7/17/2024

WS1147257886 - Network Application Services (CReed
Global Media) - MOTION

Agenda Item#: 11.

Summary:

APPROVE spending authority in the total amount of \$139,293.00 for Purchase of Network Application Services and Hardware for Houston Television from the sole source supplier, **CREED GLOBAL MEDIA, LLC dba CREED GLOBAL MEDIA** - 2 Years - State Cable TV Fund

Background:

Sole Source (P38-WS1147257886) - Approve spending authority in the total amount of \$139,293.00 for the purchase of network application services and hardware from the sole source supplier, CReed Global Media, LLC dba CReed Global Media for a two-year period for Houston Television.

Specific Explanation:

The Director of Houston Television (HTV) and the Chief Procurement Officer recommend that City Council approve spending authority for the purchase of network application services and hardware from the sole source supplier, **CReed Global Media, LLC dba CReed Global Media** in the total amount of **\$139,293.00** for HTV. These services will be provided for a period of two (2) years.

This purchase will provide HTV with a live-streamed television network enterprise package with multi-channel support, including licensing, bandwidth, hosting, and streaming service for up to four (4) channels. Additionally, the vendor will provide three (3) additional encoder stream cards for the existing HTV Teradek Prism Rack 4K 10bit encoder that provides public access to all live and streamed City Council and Council Committee meetings via SmartTV sets, Apple TV, Roku, Fire TV, Comcast Cable, Suddenlink Cable, NorthLand Cable, Facebook, YouTube, and the htvhouston.net website. The encoder cards will have a five (5) years warranty.

This recommendation is made pursuant to subsection 252.022(a)(7) of the Texas Local Government Code, which provides that "a procurement of items that are available from only one source..." is exempt from the competitive requirements for purchases.

MWBE Participation:

A 0% goal document was approved by the Office of Business Opportunity for this Agreement.

Hire Houston First:

This procurement is exempt from the City's Hire Houston First (HHF) Ordinance. Bids/proposals were not solicited because the department is utilizing a sole source vendor for this purchase.

Fiscal Note:

Funding for this item is included in the FY2025 Adopted Budget. Therefore, no Fiscal Note is required as stated in the Financial Policies.

Jedediah Greenfield
Chief Procurement Officer
Finance/Strategic Procurement Division

Department Approval Authority

Estimated Spending Authority

Department	FY2025	Out Years	Total
Mayor Houston TV	\$139,293.00	\$0	\$139,293.00

Amount and Source of Funding:

\$139,293.00 – State Cable TV (2428)

Contact Information:

Name	Dept/Division	Phone No.:
Ted Irving , Director Houston Television	MYR	(832) 393-1277
Fran Shewan, Division Manager	Finance/SPD	(832) 393-7893
Candice Gambrell, Assistant Director	Finance /SPD	(832) 393-9129
Jedediah Greenfield, Chief Procurement Officer	Finance/SPD	(832) 393-9126

ATTACHMENTS:

Description

Coversheet

Type

Signed Cover sheet



CITY OF HOUSTON - CITY COUNCIL

Meeting Date: 9/24/2024

ALL

Item Creation Date: 7/17/2024

WS1147257886 - Network Application Services (CReed Global Media) - MOTION

Agenda Item#: 13.

Background:

Sole Source (P38-WS1147257886) - Approve spending authority in the total amount of \$139,293.00 for the purchase of network application services and hardware from the sole source supplier, CReed Global Media, LLC dba CReed Global Media for a two-year period for Houston Television.

Specific Explanation:

The Director of Houston Television (HTV) and the Chief Procurement Officer recommend that City Council approve spending authority for the purchase of network application services and hardware from the sole source supplier, **CReed Global Media, LLC dba CReed Global Media** in the total amount of **\$139,293.00** for HTV. These services will be provided for a period of two (2) years.

This purchase will provide HTV with a live-streamed television network enterprise package with multi-channel support, including licensing, bandwidth, hosting, and streaming service for up to four (4) channels. Additionally, the vendor will provide three (3) additional encoder stream cards for the existing HTV Teradek Prism Rack 4K 10bit encoder that provides public access to all live and streamed City Council and Council Committee meetings via SmartTV sets, Apple TV, Roku, Fire TV, Comcast Cable, Suddenlink Cable, NorthLand Cable, Facebook, YouTube, and the htvhouston.net website. The encoder cards will have a five (5) years warranty.

This recommendation is made pursuant to subsection 252.022(a)(7) of the Texas Local Government Code, which provides that "a procurement of items that are available from only one source..." is exempt from the competitive requirements for purchases.

MWBE Participation:

A 0% goal document was approved by the Office of Business Opportunity for this Agreement.

Hire Houston First:

This procurement is exempt from the City's Hire Houston First (HHF) Ordinance. Bids/proposals were not solicited because the department is utilizing a sole source vendor for this purchase.

Fiscal Note:

Funding for this item is included in the FY2025 Adopted Budget. Therefore, no Fiscal Note is required as stated in the Financial Policies.

9/16/2024

DocuSigned by:

 6121834A077C41A...

Jedediah Greenfield

Department Approval Authority

Chief Procurement Officer
 Finance/Strategic Procurement Division

Estimated Spending Authority			
Department	FY2025	Out Years	Total
Mayor Houston TV	\$139,293.00	\$0	\$139,293.00

Amount and Source of Funding:

\$139,293.00 – State Cable TV (2428)

Contact Information:

Name	Dept/Division	Phone No.:
Ted Irving , Director Houston Television	MYR	(832) 393-1277
Fran Shewan, Division Manager	Finance/SPD	(832) 393-7893
Candice Gambrell, Assistant Director	Finance /SPD	(832) 393-9129
Jedediah Greenfield, Chief Procurement Officer	Finance/SPD	(832) 393-9126

ATTACHMENTS:

Description Type



CITY OF HOUSTON - CITY COUNCIL

Meeting Date: 9/24/2024

District C

Item Creation Date: 9/16/2024

WS1275693162 - Fertilizer (Helena Agri-Enterprises, LLC) - MOTION

Agenda Item#: 12.

Summary:

HELENA AGRI-ENTERPRISES, LLC, the Texas Local Government Purchasing Cooperative supplier for Purchase of Fertilizer for the Parks and Recreation Department - \$102,681.00 - Parks Golf Special Fund

Background:

OWS1275693162 – Approve the purchase of fertilizer through the Texas Local Government Purchasing Cooperative (BuyBoard) supplier Helena Agri-Enterprises, LLC in the total amount of \$102,681.00 for the Parks and Recreation Department.

Specific Explanation:

The Director of the Parks and Recreation Department and the Chief Procurement Officer recommend that City Council approve the purchase of fertilizer through the Texas Local Government Purchasing Cooperative (BuyBoard) supplier **Helena Agri-Enterprises, LLC** in the total amount of **\$102,681.00** for the Parks and Recreation Department.

This is for the purchase of fertilizer for the Memorial Park Golf Course, which includes Conron, Nucleus, Axio Mix, Hydra Hume, Outfront, Receptor Zypro, Renova I-Nem, Aristocracy, ENC, Brexil Multi, K-Leaf Versa, Renova, Promate, Tower and Primo Maxx Link Pak.

This recommendation is made pursuant to subsection 271.102(c) of the Texas Local Government Code, which provides that “a local government that purchases goods or services from a cooperative purchasing program or organization satisfies any state law requiring the local government to seek competitive bids for the purchase of the goods or services.

M/WBE Subcontracting:

M/WBE Zero Percentage Goal Document approved by the Office of Business Opportunity.

Hire Houston First:

This procurement is exempt from the City's Hire Houston First Ordinance. Bids/proposals were not solicited because the department is utilizing a Cooperative Purchasing Agreement for this purchase.

Fiscal Note:

Funding for this item is included in the FY25 Adopted Budget. Therefore, no Fiscal Note is required as stated in the Financial Policies.

Jedediah Greenfield
Chief Procurement Officer

Department Approval Authority

<u>Estimated Spending Authority:</u>			
Department	FY2025	Out Years	Total
Parks and Recreation Department	\$102,681.00	\$0.00	\$102,681.00

Amount and Source of Funding:

\$102,681.00
Parks Golf Special Fund
Fund 2104

Contact Information:

Jedediah Greenfield, Chief Procurement Officer – (832) 393-9126

ATTACHMENTS:

Description

Coversheet

Type

Signed Cover sheet



CITY OF HOUSTON - CITY COUNCIL

Meeting Date: 9/24/2024

District C

Item Creation Date: 9/16/2024

WS1275693162 - Fertilizer (Helena Agri-Enterprises, LLC) - MOTION

Agenda Item#: 14.

Summary:

NOT A REAL CAPTION

HELENA AGRI-ENTERPRISES, LLC for the purchase of fertilizer through the Texas Local Government Purchasing Cooperative supplier for the Parks and Recreation Department - \$102,681.00 - Parks Golf Special Fund

Background:

OWS1275693162 – Approve the purchase of fertilizer through the Texas Local Government Purchasing Cooperative (BuyBoard) supplier Helena Agri-Enterprises, LLC in the total amount of \$102,681.00 for the Parks and Recreation Department.

Specific Explanation:

The Director of the Parks and Recreation Department and the Chief Procurement Officer recommend that City Council approve the purchase of fertilizer through the Texas Local Government Purchasing Cooperative (BuyBoard) supplier **Helena Agri-Enterprises, LLC** in the total amount of **\$102,681.00** for the Parks and Recreation Department.

This is for the purchase of fertilizer for the Memorial Park Golf Course, which includes Conron, Nucleus, Axio Mix, Hydra Hume, Outfront, Receptor Zypro, Renova I-Nem, Aristocracy, ENC, Brexil Multi, K-Leaf Versa, Renova, Promate, Tower and Primo Maxx Link Pak.

This recommendation is made pursuant to subsection 271.102(c) of the Texas Local Government Code, which provides that “a local government that purchases goods or services from a cooperative purchasing program or organization satisfies any state law requiring the local government to seek competitive bids for the purchase of the goods or services.

M/WBE Subcontracting:

M/WBE Zero Percentage Goal Document approved by the Office of Business Opportunity.

Hire Houston First:

This procurement is exempt from the City's Hire Houston First Ordinance. Bids/proposals were not solicited because the department is utilizing a Cooperative Purchasing Agreement for this purchase.

Fiscal Note:

Funding for this item is included in the FY25 Adopted Budget. Therefore, no Fiscal Note is required as stated in the Financial Policies.

DocuSigned by:

6121834A077C41A...

9/18/2024

Jedediah Greenfield
Chief Procurement Officer

Department Approval Authority

Estimated Spending Authority:

Department	FY2025	Out Years	Total
Parks and Recreation Department	\$102,681.00	\$0.00	\$102,681.00

Amount and Source of Funding:

\$102,681.00
Parks Golf Special Fund
Fund 2104

Contact Information:

Jedediah Greenfield, Chief Procurement Officer – (832) 393-9126

ATTACHMENTS

ATTACHMENTS:

Description

Ownership Form
Tax Report
Cooperative Justification Form
MWBE Goal Waiver
Quote
Certification of Funds
Funding Verification

Type

Backup Material
Backup Material
Backup Material
Backup Material
Backup Material
Financial Information
Financial Information



CITY OF HOUSTON - CITY COUNCIL

Meeting Date: 9/24/2024

District C

Item Creation Date: 9/13/2024

WS1275368134 - Fertilizer and Herbicide Simplot AB Retail Inc., and Harrell's LLC) - MOTION

Agenda Item#: 13.

Summary:

SIMPLOT AB RETAIL INC - \$99,994.00 and **HARRELL'S LLC** - \$59,285.50 for Purchase of Fertilizer and Herbicide through the Texas Local Government Purchasing Cooperative (BuyBoard) suppliers for the Parks and Recreation Department - \$195,279.50 - Parks Golf Special Fund

Background:

WS1275368134 – Approve the purchase of fertilizer and herbicide through the Texas Local Government Purchasing Cooperative (BuyBoard) suppliers Simplot AB Retail Inc. and Harrell’s LLC in the total amount of \$159,279.50 for the Parks and Recreation Department.

Specific Explanation:

The Director of the Parks and Recreation Department and the Chief Procurement Officer recommend that City Council approve the purchase of fertilizer and herbicide through the Texas Local Government Purchasing Cooperative (BuyBoard) supplier **Simplot AB Retail Inc. and Harrell's LLC** in the total amount of **\$159,279.50** for the Parks and Recreation Department.

- **Simplot AB Retail Inc:** Approve the award for the purchase of fertilizer and herbicide in the amount not to exceed **\$99,994.00**.
- **Harrell’s LLC:** Approve the award for the purchase of fertilizer and herbicide in the amount not to exceed **\$59,285.50**.

This is for the purchase of fertilizer and herbicide for the Memorial Park Golf Course, which includes Nutripack, Grid Iron Plus, Ranger Pro Herbicide, Specticle Flo, YaraMila Turf Royale and Anuew EZ PGR.

This recommendation is made pursuant to subsection 271.102(c) of the Texas Local Government Code, which provides that “a local government that purchases goods or services from a cooperative purchasing program or organization satisfies any state law requiring the local government to seek competitive bids for the purchase of the goods or services.

M/WBE Subcontracting:

This procurement is exempt from the City’s MWBE subcontracting requirements as the total expenditure for each award does not exceed the \$100,000.00 threshold.

Hire Houston First:

This procurement is exempt from the City's Hire Houston First Ordinance. Bids/proposals were not solicited because the department is utilizing a Cooperative Purchasing Agreement for this purchase.

Fiscal Note:

Funding for this item is included in the FY25 Adopted Budget. Therefore, no Fiscal Note is required as stated in the Financial Policies.

Jedediah Greenfield	Department Approval Authority
Chief Procurement Officer	

<u>Estimated Spending Authority:</u>			
Department	FY2025	Out Years	Total
Parks and Recreation Department	\$159,279.50	\$0.00	\$159,279.50

Amount and Source of Funding:

\$159,279.50
Parks Golf Special Fund

Funds 201 Special Fund
Fund 2104

Contact Information:

Jedediah Greenfield, Chief Procurement Officer – (832) 393-9126

ATTACHMENTS:

Description	Type
Coversheet	Signed Cover sheet



CITY OF HOUSTON - CITY COUNCIL

Meeting Date: 9/24/2024

District C

Item Creation Date: 9/13/2024

WS1275368134 - Fertilizer and Herbicide Simplot AB Retail Inc., and Harrell's LLC) -
MOTION

Agenda Item#: 19.

Summary:

NOT A REAL CAPTION

SIMPLOT AB RETAIL INC. and **HARRELL'S LLC** for the purchase of fertilizer and herbicide through the Texas Local Government Purchasing Cooperative suppliers for the Parks and Recreation Department - \$195,279.50 - Parks Golf Special Fund

Background:

WS1275368134 – Approve the purchase of fertilizer and herbicide through the Texas Local Government Purchasing Cooperative (BuyBoard) suppliers Simplot AB Retail Inc. and Harrell's LLC in the total amount of \$159,279.50 for the Parks and Recreation Department.

Specific Explanation:

The Director of the Parks and Recreation Department and the Chief Procurement Officer recommend that City Council approve the purchase of fertilizer and herbicide through the Texas Local Government Purchasing Cooperative (BuyBoard) supplier **Simplot AB Retail Inc. and Harrell's LLC** in the total amount of **\$159,279.50** for the Parks and Recreation Department.

- **Simplot AB Retail Inc:** Approve the award for the purchase of fertilizer and herbicide in the amount not to exceed **\$99,994.00**.
- **Harrell's LLC:** Approve the award for the purchase of fertilizer and herbicide in the amount not to exceed **\$59,285.50**.

This is for the purchase of fertilizer and herbicide for the Memorial Park Golf Course, which includes Nutripack, Grid Iron Plus, Ranger Pro Herbicide, Specticle Flo, YaraMila Turf Royale and Anuew EZ PGR.

This recommendation is made pursuant to subsection 271.102(c) of the Texas Local Government Code, which provides that “a local government that purchases goods or services from a cooperative purchasing program or organization satisfies any state law requiring the local government to seek competitive bids for the purchase of the goods or services.

M/WBE Subcontracting:

This procurement is exempt from the City's MWBE subcontracting requirements as the total expenditure for each award does not exceed the \$100,000.00 threshold.

Hire Houston First:

This procurement is exempt from the City's Hire Houston First Ordinance. Bids/proposals were not solicited because the department is utilizing a Cooperative Purchasing Agreement for this purchase.

Fiscal Note:

Funding for this item is included in the FY25 Adopted Budget. Therefore, no Fiscal Note is required as stated in the Financial Policies.

9/18/2024

DocuSigned by:

Jedediah Greenfield
Chief Procurement Officer

Department Approval Authority

Estimated Spending Authority:

Department	FY2025	Out Years	Total
Parks and Recreation Department	\$159,279.50	\$0.00	\$159,279.50

Amount and Source of Funding:

\$159,279.50
Parks Golf Special Fund
Fund 2104

Contact Information:

Jedediah Greenfield, Chief Procurement Officer – (832) 393-9126

ATTACHMENTS:

Description

Ownership Form Simplot
Ownership Form Harrell's
Tax Report - Simplot
Tax Report - Harrell's
Cooperative Justification Form - Simplot
Cooperative Justification Form - Harrell's
Quote - Simplot
Quote - Harrell's
Cooperative Contract
Certification of Funds - Simplot
Certification of Funds - Harrell's
Signed Coversheet
Funding Verification

Type

Backup Material
Backup Material
Backup Material
Backup Material
Backup Material
Backup Material
Backup Material
Backup Material
Backup Material
Financial Information
Financial Information
Signed Cover sheet
Financial Information



CITY OF HOUSTON - CITY COUNCIL

Meeting Date: 9/24/2024

District C

Item Creation Date: 9/13/2024

WS127560436 - Fungicide and Insecticide (BWI Companies, Inc) - MOTION

Agenda Item#: 14.

Summary:

BWI COMPANIES, INC for Purchase of Fungicide and Insecticide through the Texas Local Government Purchasing Cooperative (BuyBoard) supplier for the Parks and Recreation Department - \$95,363.90 - Parks Golf Special Fund

Background:

WS127560436 – Approve the purchase of fungicide and insecticide through the Texas Local Government Purchasing Cooperative (BuyBoard) supplier BWI Companies, Inc in the total amount of \$95,363.90 for the Parks and Recreation Department.

Specific Explanation:

The Director of the Parks and Recreation Department and the Chief Procurement Officer recommend that City Council approve the purchase of fungicide and insecticide through the Texas Local Government Purchasing Cooperative (BuyBoard) supplier **BWI Companies, Inc** in the total amount of **\$95,363.90** for the Parks and Recreation Department.

This is for the purchase of fungicide and insecticide for the Memorial Park Golf Course, which includes Envu fungicide and Syngenta and Sapphire insecticide.

This recommendation is made pursuant to subsection 271.102(c) of the Texas Local Government Code, which provides that “a local government that purchases goods or services from a cooperative purchasing program or organization satisfies any state law requiring the local government to seek competitive bids for the purchase of the goods or services.

M/WBE Subcontracting:

This procurement is exempt from the City’s MWBE subcontracting requirements as the total expenditure does not exceed the \$100,000.00 threshold.

Hire Houston First:

This procurement is exempt from the City’s Hire Houston First Ordinance. Bids/proposals were not solicited because the department is utilizing a Cooperative Purchasing Agreement for this purchase.

Fiscal Note:

Funding for this item is included in the FY25 Adopted Budget. Therefore, no Fiscal Note is required as stated in the Financial Policies.

Jedediah Greenfield
Chief Procurement Officer

Department Approval Authority

<u>Estimated Spending Authority:</u>			
Department	FY2025	Out Years	Total
Parks and Recreation Department	\$95,363.90	\$0.00	\$95,363.90

Amount and Source of Funding:

\$95,363.90
Parks Golf Special Fund
Fund 2104

Contact Information:

Jedediah Greenfield, Chief Procurement Officer – (832) 393-9126

ATTACHMENTS:

Description

Coversheet

Type

Signed Cover sheet



CITY OF HOUSTON - CITY COUNCIL

Meeting Date: 9/24/2024

District C

Item Creation Date: 9/13/2024

WS127560436 - Fungicide and Insecticide (BWI Companies, Inc) - MOTION

Agenda Item#: 16.

Summary:

NOT A REAL CAPTION

BWI COMPANIES, INC for the purchase of fungicide and insecticide through the Texas Local Government Purchasing Cooperative supplier for the Parks and Recreation Department - \$95,363.90 - Parks Golf Special Fund

Background:

WS127560436 – Approve the purchase of fungicide and insecticide through the Texas Local Government Purchasing Cooperative (BuyBoard) supplier BWI Companies, Inc in the total amount of \$95,363.90 for the Parks and Recreation Department.

Specific Explanation:

The Director of the Parks and Recreation Department and the Chief Procurement Officer recommend that City Council approve the purchase of fungicide and insecticide through the Texas Local Government Purchasing Cooperative (BuyBoard) supplier **BWI Companies, Inc** in the total amount of **\$95,363.90** for the Parks and Recreation Department.

This is for the purchase of fungicide and insecticide for the Memorial Park Golf Course, which includes Envu fungicide and Syngenta and Sapphire insecticide.

This recommendation is made pursuant to subsection 271.102(c) of the Texas Local Government Code, which provides that “a local government that purchases goods or services from a cooperative purchasing program or organization satisfies any state law requiring the local government to seek competitive bids for the purchase of the goods or services.

M/WBE Subcontracting:

This procurement is exempt from the City's MWBE subcontracting requirements as the total expenditure does not exceed the \$100,000.00 threshold.

Hire Houston First:

This procurement is exempt from the City's Hire Houston First Ordinance. Bids/proposals were not solicited because the department is utilizing a Cooperative Purchasing Agreement for this purchase.

Fiscal Note:

Funding for this item is included in the FY25 Adopted Budget. Therefore, no Fiscal Note is required as stated in the Financial Policies.

9/18/2024

DocuSigned by:

6121834A077C41A...

Jedediah Greenfield
Chief Procurement Officer

Department Approval Authority

Estimated Spending Authority:

Department	FY2025	Out Years	Total
Parks and Recreation Department	\$95,363.90	\$0.00	\$95,363.90

Amount and Source of Funding:

\$95,363.90
Parks Golf Special Fund
Fund 2104

Contact Information:

Jedediah Greenfield, Chief Procurement Officer – (832) 393-9126

ATTACHMENTS

ATTACHMENTS:

Description

Ownership Form
Tax Report
Cooperative Justification Form
Cooperative Contract
Quote
Certification of Funds
Funding Verification

Type

Backup Material
Backup Material
Backup Material
Backup Material
Backup Material
Financial Information
Financial Information



CITY OF HOUSTON - CITY COUNCIL

Meeting Date: 9/24/2024

District C

Item Creation Date: 9/16/2024

WS127560498 - Grass Seed (Heritage PPG) - MOTION

Agenda Item#: 15.

Summary:

HERITAGE PPG for Purchase of Grass Seed through the Texas Local Government Purchasing Cooperative (BuyBoard) supplier for the Parks and Recreation Department - \$213,365.60 - Parks Golf Special Fund

Background:

WS127560498 – Approve the purchase of grass seed through the Texas Local Government Purchasing Cooperative (BuyBoard) supplier Heritage PPG in the total amount of \$213,365.60 for the Parks and Recreation Department.

Specific Explanation:

The Director of the Parks and Recreation Department and the Chief Procurement Officer recommend that City Council approve the purchase of grass seed through the Texas Local Government Purchasing Cooperative (BuyBoard) supplier **Heritage PPG** in the total amount of **\$213,365.60** for the Parks and Recreation Department.

This is for the purchase of grass seed for the Memorial Park Golf Course, which includes Champion Fine Seed Blend, Maximum POA Triva Blend, 46-0-0 Fairway and 21-0-0 Fairway grass seed.

This recommendation is made pursuant to subsection 271.102(c) of the Texas Local Government Code, which provides that “a local government that purchases goods or services from a cooperative purchasing program or organization satisfies any state law requiring the local government to seek competitive bids for the purchase of the goods or services.

M/WBE Subcontracting:

M/WBE Zero Percentage Goal Document approved by the Office of Business Opportunity.

Hire Houston First:

This procurement is exempt from the City's Hire Houston First Ordinance. Bids/proposals were not solicited because the department is utilizing a Cooperative Purchasing Agreement for this purchase.

Fiscal Note:

Funding for this item is included in the FY25 Adopted Budget. Therefore, no Fiscal Note is required as stated in the Financial Policies.

Jedediah Greenfield Chief Procurement Officer	Department Approval Authority
---	--------------------------------------

Estimated Spending Authority:			
Department	FY2025	Out Years	Total
Parks and Recreation Department	\$213,365.60	\$0.00	\$213,365.60

Amount and Source of Funding:

\$213,365.60
Parks Golf Special Fund
Fund 2104

Contact Information:

Jedediah Greenfield, Chief Procurement Officer – (832) 393-9126

ATTACHMENTS:

Description

Coversheet

Type

Signed Cover sheet



CITY OF HOUSTON - CITY COUNCIL

Meeting Date: 9/24/2024

District C

Item Creation Date: 9/16/2024

WS127560498 - Grass Seed (Heritage PPG) - MOTION

Agenda Item#: 17.

Summary:

NOT A REAL CAPTION

HERITAGE PPG for the purchase of grass seed through the Texas Local Government Purchasing Cooperative supplier for the Parks and Recreation Department - \$213,365.60 - Parks Golf Special Fund

Background:

WS127560498 – Approve the purchase of grass seed through the Texas Local Government Purchasing Cooperative (BuyBoard) supplier Heritage PPG in the total amount of \$213,365.60 for the Parks and Recreation Department.

Specific Explanation:

The Director of the Parks and Recreation Department and the Chief Procurement Officer recommend that City Council approve the purchase of grass seed through the Texas Local Government Purchasing Cooperative (BuyBoard) supplier **Heritage PPG** in the total amount of **\$213,365.60** for the Parks and Recreation Department.

This is for the purchase of grass seed for the Memorial Park Golf Course, which includes Champion Fine Seed Blend, Maximum POA Triva Blend, 46-0-0 Fairway and 21-0-0 Fairway grass seed.

This recommendation is made pursuant to subsection 271.102(c) of the Texas Local Government Code, which provides that “a local government that purchases goods or services from a cooperative purchasing program or organization satisfies any state law requiring the local government to seek competitive bids for the purchase of the goods or services.

M/WBE Subcontracting:

M/WBE Zero Percentage Goal Document approved by the Office of Business Opportunity.

Hire Houston First:

This procurement is exempt from the City's Hire Houston First Ordinance. Bids/proposals were not solicited because the department is utilizing a Cooperative Purchasing Agreement for this purchase.

Fiscal Note:

Funding for this item is included in the FY25 Adopted Budget. Therefore, no Fiscal Note is required as stated in the Financial Policies.

9/18/2024

DocuSigned by:

6121834A077C41A...

Jedediah Greenfield
Chief Procurement Officer

Department Approval Authority

Estimated Spending Authority:

Department	FY2025	Out Years	Total
Parks and Recreation Department	\$213,365.60	\$0.00	\$213,365.60

Amount and Source of Funding:

\$213,365.60
Parks Golf Special Fund
Fund 2104

Contact Information:

Jedediah Greenfield, Chief Procurement Officer – (832) 393-9126

ATTACHMENTS:

Resolution _____ Title _____

Description

Ownership Form
Tax Report
Cooperative Justification Form
Quote
MWBE Goal Waiver
Certification of Funds
Funding Verification

Type

Backup Material
Backup Material
Backup Material
Backup Material
Backup Material
Financial Information
Financial Information



CITY OF HOUSTON - CITY COUNCIL

Meeting Date: 9/24/2024

ALL

Item Creation Date:

DOC1064421390-Signposts and Associated Hardware (Canuck Power, Inc.) - MOTION

Agenda Item#: 16.

Summary:

CANUCK POWER, INC. for Signposts and associated hardware for Houston Public Works - 3 Years with 2 one-year options - \$3,003,400.00 - Special Revenue Fund

Background:

Formal Bids Received on May 30, 2024, for P04-D0C1064421390 - Approve an award to Canuck Power, Inc. in an amount not to exceed \$3,003,400.00 for signposts and associated hardware for a thirty-six (36) month period with two (2) one (1) year options for Houston Public works.

Specific Explanation:

The Chief Operating Officer of Houston Public Works and the Chief Procurement Officer recommend that City Council approve an award to **Canuck Power, Inc.** on its sole bid in the amount not to exceed **\$3,003,400.00** for signposts and associated hardware for a thirty-six (36) month period with two (2) one (1) year options for Houston Public Works.

The award encompasses various hardware items such as signposts, anchors, clamps, brackets, and sign holders. These items are intended to support the department's day-to-day business activities conducted across the city. This purchase is a critical step towards ensuring that HPW has the necessary signposts and hardware to carry out its operations effectively.

This project was advertised in accordance with the requirements of the State of Texas bid laws and one (1) bid was received as stated below:

Company	Total
Canuck Power, Inc.	\$3,003,400.00

MWBE Participation:

Zero percentage goal-document approved by the Office of Business Opportunity.

Hire Houston First:

The proposed award requires compliance with the City's 'Hire Houston First' (HHF) ordinance that promotes economic opportunity for Houston businesses and supports job creation. In this case, Canuck Power, Inc does not meet the requirements for HHF designation; no HHF firms were within three percent.

Fiscal Note:

Funding for this item is included in the FY2025 Adopted Budget. Therefore, no Fiscal Note is required as stated in the Financial Policies.

Jedediah Greenfield, Chief Procurement Officer
Finance/Strategic Procurement Division

Randall V. Macchi, Chief Operating Officer
Houston Public Works

Department	Estimated Spending Authority		Total
	FY2025	Out Years	
Houston Public Works	\$600,680.00	\$2,402,720.00	\$3,003,400.00

Amount and Source of Funding:

\$3,003,400.00

Dedicated Drainage & Street Renewal - Metro et al

Fund No.: 2312

Contact Information:

Name	Dept/Division	Phone No.:
Erika Lawton, Division Manager	HPW/SPD	(832) 395-2833
Brian Blum, Assistant Director	HPW/PFW	(832) 395-2717
Carolyn Hanahan, Assistant Chief Policy Officer	Finance/SPD	(832) 393-9127
Jedediah Greenfield, Chief Procurement Officer	Finance/SPD	(832) 393-9126

ATTACHMENTS:

Description	Type
Coversheet	Signed Cover sheet



CITY OF HOUSTON - CITY COUNCIL

Meeting Date:
ALL
Item Creation Date:

DOC1064421390-Signposts and Associated Hardware (Canuck Power, Inc.) - MOTION

Agenda Item#:

Background:

Formal Bids Received on May 30, 2024, for P04-D0C1064421390 - Approve an award to Canuck Power, Inc. in an amount not to exceed \$3,003,400.00 for signposts and associated hardware for a thirty-six (36) month period with two (2) one (1) year options for Houston Public works.

Specific Explanation:

The Chief Operating Officer of Houston Public Works and the Chief Procurement Officer recommend that City Council approve an award to **Canuck Power, Inc.** on its sole bid in the amount not to exceed **\$3,003,400.00** for signposts and associated hardware for a thirty-six (36) month period with two (2) one (1) year options for Houston Public Works.

The award encompasses various hardware items such as signposts, anchors, clamps, brackets, and sign holders. These items are intended to support the department's day-to-day business activities conducted across the city. This purchase is a critical step towards ensuring that HPW has the necessary signposts and hardware to carry out its operations effectively.

This project was advertised in accordance with the requirements of the State of Texas bid laws and one (1) bid was received as stated below:

Company	Total
Canuck Power, Inc.	\$3,003,400.00

MWBE Participation:

Zero percentage goal-document approved by the Office of Business Opportunity.

Hire Houston First:

The proposed award requires compliance with the City's 'Hire Houston First' (HHF) ordinance that promotes economic opportunity for Houston businesses and supports job creation. In this case, Canuck Power, Inc does not meet the requirements for HHF designation; no HHF firms were within three percent.

Fiscal Note:

Funding for this item is included in the FY2025 Adopted Budget. Therefore, no Fiscal Note is required as stated in the Financial Policies.

9/11/2024

DocuSigned by:

6121834A07ZC41A...

DocuSigned by:

BE463EF0DF454EB...

9/13/2024

Jedediah Greenfield, Chief Procurement Officer
Finance/Strategic Procurement Division

Randall V. Macchi, Chief Operating Officer
Houston Public Works

DS

Department	Estimated Spending Authority		Total
	FY2025	Out Years	
Houston Public Works	\$600,680.00	\$2,402,720.00	\$3,003,400.00

Amount and Source of Funding:

\$3,003,400.00
Dedicated Drainage & Street Renewal - Metro et al
Fund No.: 2312

Contact Information:

Name	Dept/Division	Phone No.:
Erika Lawton, Division Manager	HPW/SPD	(832) 395-2833
Brian Blum, Assistant Director	HPW/PFW	(832) 395-2717
Carolyn Hanahan, Assistant Chief Policy Officer	Finance/SPD	(832) 393-9127
Jedediah Greenfield, Chief Procurement Officer	Finance/SPD	(832) 393-9126

ATTACHMENTS:

Description

DOC1064421390 - Bid Tab
DOC1064421390-Ownership Form
DOC1064421390-Tax Form
DOC1064421390-MWBE Forms
DOC1064421390-Conflict of Interest
DOC1064421390 - Form A
Budget vs Actual DOC1064421390

Type

Backup Material
Backup Material
Backup Material
Backup Material
Backup Material
Financial Information
Financial Information



CITY OF HOUSTON - CITY COUNCIL

Meeting Date: 9/24/2024

ALL

Item Creation Date: 9/13/2024

MYR - TML Region 14 Ballot

Agenda Item#: 17.

Summary:

RESOLUTION of the City Council of the City of Houston casting its vote for **JOE ZIMMERMAN, MAYOR**, City of Sugar Land, Texas, for Region 14 Director on the Texas Municipal League Board of Directors

Background:

The Texas Municipal League (TML) has 15 sub-state regions (regions 2 through 16) that were formed in 1958. Regions exist to promote interests in city government on a regional level, facilitate the exchange of information among the cities in a region, and assist the TML Board of Directors in formulating policy that represents the diverse interests of the state.

Each region elects officers and conducts regional meetings at least twice each year. Each region also elects a representative to serve on the TML Board of Directors. The board representative must be an elected official from a city within the region and serves a two-year term of office with a maximum of two full terms. Each region may have only one board representative. The new term will begin on October 11, 2024, upon adjournment of the TML Annual Conference.

Two officials from the region were nominated and the City of Houston is entitled to vote for one candidate. The nominations this year are Frank W. Robinson, Councilmember, Shenandoah and Joe Zimmerman, Mayor, Sugar Land.

It is recommended that the City Council adopt a resolution casting its ballot for Mayor Joe Zimmerman for Texas Municipal League Region 14 Director.

Joshua Sanders, Mayor's Office of Intergovernmental Relations

Contact Information:

Joshua Sanders, Chief of Intergovernmental Relations
832-393-0805

ATTACHMENTS:

Description

Type

Coversheet (revised)

Signed Cover sheet



CITY OF HOUSTON - CITY COUNCIL

Meeting Date: 9/24/2024

ALL

Item Creation Date: 9/13/2024

MYR - TML Region 14 Ballot

Agenda Item#: 23.

Summary:

NOT A REAL CAPTION

RESOLUTION supporting nomination of **MAYOR JOE ZIMMERMAN, SUGAR LAND, TEXAS** to the Texas Municipal League Board of Directors

Background:

The Texas Municipal League (TML) has 15 sub-state regions (regions 2 through 16) that were formed in 1958. Regions exist to promote interests in city government on a regional level, facilitate the exchange of information among the cities in a region, and assist the TML Board of Directors in formulating policy that represents the diverse interests of the state.

Each region elects officers and conducts regional meetings at least twice each year. Each region also elects a representative to serve on the TML Board of Directors. The board representative must be an elected official from a city within the region and serves a two-year term of office with a maximum of two full terms. Each region may have only one board representative. The new term will begin on October 11, 2024, upon adjournment of the TML Annual Conference.

Two officials from the region were nominated and the City of Houston is entitled to vote for one candidate. The nominations this year are Frank W. Robinson, Councilmember, Shenandoah and Joe Zimmerman, Mayor, Sugar Land.

It is recommended that the City Council adopt a resolution casting its ballot for Mayor Joe Zimmerman for Texas Municipal League Region 14 Director.

Signed by:

Handwritten signature of Joshua Sanders in blue ink.

Joshua Sanders, Mayor's Office of Intergovernmental Relations
9/18/2024

Contact Information:

Joshua Sanders, Chief of Intergovernmental Relations
832-393-0805

ATTACHMENTS:

Description	Type
Ballot	Signed Cover sheet



CITY OF HOUSTON - CITY COUNCIL

Meeting Date: 9/24/2024
District A, District D, District K
Item Creation Date: 8/30/2024

HCD24-88 HHA PFC Resolution of Approval

Agenda Item#: 18.

Summary:

RESOLUTION confirming approval of proposed Affordable Multifamily Residential Developments seeking exemption from taxation, with each development being owned by a Public Facility Corporation created and existing under Chapter 303 of the Texas Local Government Code and located in the City of Houston, Texas - **DISTRICTS A - PECK; D - EVANS-SHABAZZ and K - CASTEX-TATUM**

Background:

The Housing and Community Development Department (HCD) recommends Council approve a Resolution of Approval for three Houston Housing Authority Public Facility Corporations (PFC's) seeking tax exemptions for the multifamily mixed-income housing developments listed below:

Development Name	Development Address	Council District	Construction Type	Target Population
Allora Med Center	10201 Main St, 77025	K	New	General Population
Ariza Park Row	1100 Blackhaw St, 77079	A	New	General Population
Orem Circle	12781 Martin Luther King Blvd, 77048	D	New	General Population

Chapter 303 of the Texas Local Government Code provides an exemption from property taxation for multifamily residential developments that meet certain requirements, including that the development be approved by the governing body of the municipality in which the development is located.

HCD has performed a threshold review and recommends a Resolution of Approval for the following reasons:

- Allora Med Center – High Opportunity Area
- Ariza Park Row – High Opportunity Area
- Orem Circle – Gulfgate TIRZ

The Houston Housing Authority will hold a public hearing for the PFCs listed above on October 15, 2024.

This item was reviewed by the Housing and Affordability Committee on September 17, 2024.

Michael Nichols, Director

Contact Information:

Roxanne Lawson
(832) 394-6307

ATTACHMENTS:

Description

Coversheet (revised)

Type

Signed Cover sheet



CITY OF HOUSTON - CITY COUNCIL

Meeting Date: 9/24/2024
 District A, District D, District K
 Item Creation Date: 8/30/2024

HCD24-88 HHA PFC Resolution of Approval

Agenda Item#: 21.

Summary:

RESOLUTION confirming approval of the proposed affordable multifamily residential developments seeking exemption from taxation, with each development being owned by a public facility corporation created and existing under Chapter 303 of the Texas Local Government Code and located in the City of Houston, Texas - **DISTRICT A - PECK; D - EVANS-SHABAZZ** and **K - CASTEX-TATUM**

Background:

The Housing and Community Development Department (HCD) recommends Council approve a Resolution of Approval for three Houston Housing Authority Public Facility Corporations (PFC's) seeking tax exemptions for the multifamily mixed-income housing developments listed below:

Development Name	Development Address	Council District	Construction Type	Target Population
Allora Med Center	10201 Main St, 77025	K	New	General Population
Ariza Park Row	1100 Blackhaw St, 77079	A	New	General Population
Orem Circle	12781 Martin Luther King Blvd, 77048	D	New	General Population

Chapter 303 of the Texas Local Government Code provides an exemption from property taxation for multifamily residential developments that meet certain requirements, including that the development be approved by the governing body of the municipality in which the development is located.

HCD has performed a threshold review and recommends a Resolution of Approval for the following reasons:

- Allora Med Center – High Opportunity Area
- Ariza Park Row – High Opportunity Area
- Orem Circle – Gulfgate TIRZ

The Houston Housing Authority will hold a public hearing for the PFCs listed above on October 15, 2024.

This item was reviewed by the Housing and Affordability Committee on September 17, 2024.

DocuSigned by:

Michael Nichols, Director

Contact Information:

Roxanne Lawson
 (832) 394-6307

ATTACHMENTS:

Description	Type
Cover Sheet	Signed Cover sheet
Signed Resolution	Ordinance/Resolution/Motion



CITY OF HOUSTON - CITY COUNCIL

Meeting Date: 9/24/2024

ALL

Item Creation Date: 9/12/2024

HHD – B & N EXPRESS EMS INC.

Agenda Item#: 19.

Summary:

RESOLUTION authorizing issuance of Letter of Approval to **B&N EXPRESS EMS INC** pursuant to Section 773.0573 of the Texas Health and Safety Code

Background:

RECOMMENDATION:

A resolution authorizing the issuance of a letter of approval to **B & N EXPRESS EMS INC** pursuant to Section 773.0573 of the Texas Health and Safety Code.

SPECIFIC EXPLANATION:

The Houston Health Department (HHD) requests City Council's approval of a resolution authorizing the issuance of a Letter of Approval (LOA) to B & N Express EMS Inc. pursuant to § 773.0573 of the Texas Health and Safety Code.

During the 83rd Legislative Session, the Texas Legislature and the Governor approved Senate Bill 8 which amended § 773.0573 of the Health and Safety Code to require that a new EMS provider seeking a state EMS license must first obtain a letter of approval from the governing body or commissioners court of the jurisdiction in which the applicant is located and intends to provide EMS services.

Section 773.0573 provides that the governing body or commissioners court may issue an LOA if it is determined that:

(1) the addition of another licensed emergency medical services provider will not interfere with or adversely affect the provision of emergency medical services by the licensed emergency medical services providers operating in the municipality or county;

Determination: The addition of these EMS providers will not adversely affect the provision of EMS services because only HFD is authorized to provide emergency medical services in the City; State licensed EMS providers are not authorized to do so except under certain, limited circumstances after providing notice to HFD. They provide private nonemergency transport services. Therefore, a new private provider would not interfere with emergency medical service providers.

(2) the addition of another licensed emergency medical services provider will remedy an existing provider shortage that cannot be resolved through the use of the licensed emergency medical services providers operating in the municipality or county; and

Determination: Citizens, hospitals, and other entities continue contacting HFD for nonemergency medical transports which takes HFD away from providing emergency transport services. In 2019, HFD provided 5070 nonemergency transports to/from dialysis facilities, doctors' offices, clinics and hospitals. There are 85 EMS providers currently licensed in the city. Additional providers will offer the community more EMS service providers for nonemergency transports which should reduce the number of nonemergency calls received by HFD.

(3) the addition of another licensed emergency medical services provider will not cause an oversupply of licensed emergency medical services providers in the municipality or county.

Determination: There are 85 EMS providers licensed by the City and HHD has not received any complaints or concerns from citizens or the stakeholder community regarding an oversupply of providers. This is a relatively low number given the city's population.

Based on the application submitted by **B & N EXPRESS EMS INC**, HHD recommends City council approve the issuance of a letter of approval to B & N Express EMS Inc.

Stephen L. Williams, M.Ed., MPA
Director - Houston Health Department

Contact Information:
Porfirio Villarreal; Health Department
832-393-5041; 713-826-5695

ATTACHMENTS:

Description

RCA Coversheet (Signed)

Type

Signed Cover sheet



CITY OF HOUSTON - CITY COUNCIL

Meeting Date: 9/24/2024

ALL

Item Creation Date: 9/12/2024

HHD – B & N EXPRESS EMS INC.

Agenda Item#: 15.

Summary:

A RESOLUTION AUTHORIZING THE ISSUANCE OF A LETTER OF APPROVAL TO B&N EXPRESS EMS INC PURSUANT TO SECTION 773.0573 OF THE TEXAS HEALTH AND SAFETY CODE; CONTAINING FINDINGS AND OTHER PROVISIONS RELATED TO THE FOREGOING SUBJECT; PROVIDING FOR SEVERABILITY; AND DECLARING AN EMERGENCY.

Background:

RECOMMENDATION:

A resolution authorizing the issuance of a letter of approval to **B & N EXPRESS EMS INC** pursuant to Section 773.0573 of the Texas Health and Safety Code.

SPECIFIC EXPLANATION:

The Houston Health Department (HHD) requests City Council's approval of a resolution authorizing the issuance of a Letter of Approval (LOA) to B & N Express EMS Inc. pursuant to § 773.0573 of the Texas Health and Safety Code.

During the 83rd Legislative Session, the Texas Legislature and the Governor approved Senate Bill 8 which amended § 773.0573 of the Health and Safety Code to require that a new EMS provider seeking a state EMS license must first obtain a letter of approval from the governing body or commissioners court of the jurisdiction in which the applicant is located and intends to provide EMS services.

Section 773.0573 provides that the governing body or commissioners court may issue an LOA if it is determined that:

(1) the addition of another licensed emergency medical services provider will not interfere with or adversely affect the provision of emergency medical services by the licensed emergency medical services providers operating in the municipality or county;

Determination: The addition of these EMS providers will not adversely affect the provision of EMS services because only HFD is authorized to provide emergency medical services in the City; State licensed EMS providers are not authorized to do so except under certain, limited circumstances after providing notice to HFD. They provide private nonemergency transport services. Therefore, a new private provider would not interfere with emergency medical service providers.

(2) the addition of another licensed emergency medical services provider will remedy an existing provider shortage that cannot be resolved through the use of the licensed emergency medical services providers operating in the municipality or county; and

Determination: Citizens, hospitals, and other entities continue contacting HFD for nonemergency medical transports which takes HFD away from providing emergency transport services. In 2019, HFD provided 5070 nonemergency transports to/from dialysis facilities, doctors' offices, clinics and hospitals. There are 85 EMS providers currently licensed in the city. Additional providers will offer the community more EMS service providers for nonemergency transports which should reduce the number of nonemergency calls received by HFD.

(3) the addition of another licensed emergency medical services provider will not cause an oversupply of licensed emergency medical services providers in the municipality or county.

Determination: There are 85 EMS providers licensed by the City and HHD has not received any complaints or concerns from citizens or the stakeholder community regarding an oversupply of providers. This is a relatively low number given the city's population.

Based on the application submitted by **B & N EXPRESS EMS INC**, HHD recommends City council approve the issuance of a letter of approval to B & N Express EMS Inc.

DocuSigned by:

Stephen Williams

A8219D332CF4498...

Stephen L. Williams, M.Ed., MPA
Director - Houston Health Department

Contact Information:

Porfirio Villarreal; Health Department

832-393-5041; 713-826-5695

ATTACHMENTS:

Description

Letter of Approval Application

Type

Contract/Exhibit



CITY OF HOUSTON - CITY COUNCIL

Meeting Date: 9/24/2024

ALL

Item Creation Date:

HHD – IMPACT EMS

Agenda Item#: 20.

Summary:

RESOLUTION authorizing issuance of Letter of Approval to **IMPACT EMS** pursuant to Section 773.0573 of the Texas Health and Safety Code

Background:

RECOMMENDATION:

A resolution authorizing the issuance of a letter of approval to **IMPACT EMS** pursuant to Section 773.0573 of the Texas Health and Safety Code.

SPECIFIC EXPLANATION:

The Houston Health Department (HHD) requests City Council's approval of a resolution authorizing the issuance of a Letter of Approval (LOA) to Impact EMS pursuant to § 773.0573 of the Texas Health and Safety Code.

During the 83rd Legislative Session, the Texas Legislature and the Governor approved Senate Bill 8 which amended § 773.0573 of the Health and Safety Code to require that a new EMS provider seeking a state EMS license must first obtain a letter of approval from the governing body or commissioners court of the jurisdiction in which the applicant is located and intends to provide EMS services.

Section 773.0573 provides that the governing body or commissioners court may issue an LOA if it is determined that:

(1) the addition of another licensed emergency medical services provider will not interfere with or adversely affect the provision of emergency medical services by the licensed emergency medical services providers operating in the municipality or county;

Determination: The addition of these EMS providers will not adversely affect the provision of EMS services because only HFD is authorized to provide emergency medical services in the City; State licensed EMS providers are not authorized to do so except under certain, limited circumstances after providing notice to HFD. They provide private nonemergency transport services. Therefore, a new private provider would not interfere with emergency medical service providers.

(2) the addition of another licensed emergency medical services provider will remedy an existing provider shortage that cannot be resolved through the use of the licensed emergency medical services providers operating in the municipality or county; and

Determination: Citizens, hospitals, and other entities continue contacting HFD for nonemergency medical transports which takes HFD away from providing emergency transport services. In 2019, HFD provided 5070 nonemergency transports to/from dialysis facilities, doctors' offices, clinics and hospitals. There are 85 EMS providers currently licensed in the city. Additional providers will offer the community more EMS service providers for nonemergency transports which should reduce the number of nonemergency calls received by HFD.

(3) the addition of another licensed emergency medical services provider will not cause an oversupply of licensed emergency medical services providers in the municipality or county.

Determination: There are 85 EMS providers licensed by the City and HHD has not received any complaints or concerns from citizens or the stakeholder community regarding an oversupply of providers. This is a relatively low number given the city's population.

Based on the application submitted by **IMPACT EMS**, HHD recommends City council approve the issuance of a letter of approval to Impact EMS.

Stephen L. Williams, M.Ed., MPA
Director - Houston Health Department

Contact Information:
Porfirio Villarreal; Health Department
832-393-5041; 713-826-5695

ATTACHMENTS:

Description

RCA Coversheet (Signed)

Type

Signed Cover sheet



CITY OF HOUSTON - CITY COUNCIL

Meeting Date: 9/24/2024

ALL

Item Creation Date:

HHD – IMPACT EMS

Agenda Item#: 15.

Summary:

A RESOLUTION AUTHORIZING THE ISSUANCE OF A LETTER OF APPROVAL TO IMPACT EMS PURSUANT TO SECTION 773.0573 OF THE TEXAS HEALTH AND SAFETY CODE; CONTAINING FINDINGS AND OTHER PROVISIONS RELATED TO THE FOREGOING SUBJECT; PROVIDING FOR SEVERABILITY; AND DECLARING AN EMERGENCY.

Background:

RECOMMENDATION:

A resolution authorizing the issuance of a letter of approval to **IMPACT EMS** pursuant to Section 773.0573 of the Texas Health and Safety Code.

SPECIFIC EXPLANATION:

The Houston Health Department (HHD) requests City Council's approval of a resolution authorizing the issuance of a Letter of Approval (LOA) to Impact EMS pursuant to § 773.0573 of the Texas Health and Safety Code.

During the 83rd Legislative Session, the Texas Legislature and the Governor approved Senate Bill 8 which amended § 773.0573 of the Health and Safety Code to require that a new EMS provider seeking a state EMS license must first obtain a letter of approval from the governing body or commissioners court of the jurisdiction in which the applicant is located and intends to provide EMS services.

Section 773.0573 provides that the governing body or commissioners court may issue an LOA if it is determined that:

(1) the addition of another licensed emergency medical services provider will not interfere with or adversely affect the provision of emergency medical services by the licensed emergency medical services providers operating in the municipality or county;

Determination: The addition of these EMS providers will not adversely affect the provision of EMS services because only HFD is authorized to provide emergency medical services in the City; State licensed EMS providers are not authorized to do so except under certain, limited circumstances after providing notice to HFD. They provide private nonemergency transport services. Therefore, a new private provider would not interfere with emergency medical service providers.

(2) the addition of another licensed emergency medical services provider will remedy an existing provider shortage that cannot be resolved through the use of the licensed emergency medical services providers operating in the municipality or county; and

Determination: Citizens, hospitals, and other entities continue contacting HFD for nonemergency medical transports which takes HFD away from providing emergency transport services. In 2019, HFD provided 5070 nonemergency transports to/from dialysis facilities, doctors' offices, clinics and hospitals. There are 85 EMS providers currently licensed in the city. Additional providers will offer the community more EMS service providers for nonemergency transports which should reduce the number of nonemergency calls received by HFD.

(3) the addition of another licensed emergency medical services provider will not cause an oversupply of licensed emergency medical services providers in the municipality or county.

Determination: There are 85 EMS providers licensed by the City and HHD has not received any complaints or concerns from citizens or the stakeholder community regarding an oversupply of providers. This is a relatively low number given the city's population.

Based on the application submitted by **IMPACT EMS**, HHD recommends City council approve the issuance of a letter of approval to Impact EMS.

DocuSigned by:

Stephen Williams

A8219D332CF4498...

Stephen L. Williams, M.Ed., MPA
Director - Houston Health Department

Contact Information:

Porfirio Villarreal; Health Department
832-393-5041; 713-826-5695



CITY OF HOUSTON - CITY COUNCIL

Meeting Date: 9/24/2024

ALL

Item Creation Date: 9/10/2024

HITS- POTS/ Analog Service Replacement Appropriation

Agenda Item#: 21.

Summary:

ORDINANCE appropriating \$100,000.00 out of FY25 Equipment Acquisition Consolidated Fund for Analog/Plain Old Telephone System Service Replacement Project for Houston Information Technology Services

Background:

Specific Explanation:

The Chief Information Officer recommends that City Council approve an ordinance to appropriate \$100,000.00 from the Equipment Acquisition Consolidated Fund (1800) for the planned Analog/Plain Old Telephone System (POTS) Service Replacement Project for Houston Information Technology Services (HITS). This Project is budgeted in the approved FY2025 Capital Improvement Plan adopted by City Council.

The Project description with allocation amount is as follows:

<u>PROJECT</u>	<u>PROJECT NO.</u>	<u>AMOUNT</u>
Analog/POTS Service Replacement	WBS# X-680108*	\$100,000.00

The planned Analog /Plain Old Telephone System (POTS) Service Replacement Project will replace plain old telephone (POTS) lines including those used by elevator emergency phones, fire alarm panels, and various other emergency uses, to a cellular with Wide Area Network (WAN) connectivity. The requested appropriation will allow for the replacement of POTS lines that can no longer be fixed or replaced by the carrier due to aged infrastructure. The planned replacement will also ensure the City is in compliance with requirements related to elevators and fire alarm panels by replacing the POTS lines with a safety rated IP based solution. HITS will leverage cooperative contract(s) and/or existing enterprise contract(s) for the purchase of hardware.

Fiscal Note:

No significant Fiscal Operating impact is anticipated because of this project.

**Lisa Kent, Chief Information Officer
Houston Information Technology Services**

Amount and Source of Funding:

\$100,000.00

FY25 Equipment Acquisition Consolidated Fund
Fund 1800

Contact Information:

Jane Wu, Deputy Director
HITS, DBM

Phone: 832.393.0013

ATTACHMENTS:

Description

Signed Coversheet

Type

Signed Cover sheet



CITY OF HOUSTON - CITY COUNCIL

Meeting Date: 9/24/2024

ALL

Item Creation Date: 9/10/2024

HITS- POTS/ Analog Service Replacement Appropriation

Agenda Item#: 25.

Background:

Specific Explanation:

The Chief Information Officer recommends that City Council approve an ordinance to appropriate \$100,000.00 from the Equipment Acquisition Consolidated Fund (1800) for the planned Analog/Plain Old Telephone System (POTS) Service Replacement Project for Houston Information Technology Services (HITS). This Project is budgeted in the approved FY2025 Capital Improvement Plan adopted by City Council.

The Project description with allocation amount is as follows:

<u>PROJECT</u>	<u>PROJECT NO.</u>	<u>AMOUNT</u>
Analog/POTS Service Replacement	WBS# X-680108*	\$100,000.00

The planned Analog /Plain Old Telephone System (POTS) Service Replacement Project will replace plain old telephone (POTS) lines including those used by elevator emergency phones, fire alarm panels, and various other emergency uses, to a cellular with Wide Area Network (WAN) connectivity. The requested appropriation will allow for the replacement of POTS lines that can no longer be fixed or replaced by the carrier due to aged infrastructure. The planned replacement will also ensure the City is in compliance with requirements related to elevators and fire alarm panels by replacing the POTS lines with a safety rated IP based solution. HITS will leverage cooperative contract(s) and/or existing enterprise contract(s) for the purchase of hardware.

Fiscal Note:

No significant Fiscal Operating impact is anticipated because of this project.

DocuSigned by:

 44FF8FE8CCB7481...

Lisa Kent, Chief Information Officer
Houston Information Technology Services

Prior Council Action:

N/A

Amount and Source of Funding:

\$100,000.00 - FY25 Equipment Acquisition Consolidated Fund (1800)

Contact Information:

Jane Wu, Deputy Director
 HITS, DBM
 832.393.0013



ATTACHMENTS:

Description	Type
COF	Financial Information
Fiscal Note	Financial Information
FMBB doc	Financial Information
SAP Form A	Financial Information



CITY OF HOUSTON - CITY COUNCIL

Meeting Date: 9/24/2024

ALL

Item Creation Date: 9/4/2024

HITS- CAD Infrastructure Refresh Appropriation

Agenda Item#: 22.

Summary:

ORDINANCE appropriating \$100,000.00 out of FY25 Equipment Acquisition Consolidated Fund for CAD Infrastructure Refresh Project for Houston Information Technology Services

Background:

Specific Explanation:

The Chief Information Officer recommends that City Council approve an ordinance to appropriate \$100,000.00 from the Equipment Acquisition Consolidated Fund (1800) for the planned CAD Infrastructure Refresh Project for Houston Information Technology Services. This Project is budgeted in the approved FY2025 Capital Improvement Plan adopted by City Council.

The Project description with allocation amount is as follows:

<u>PROJECT</u>	<u>PROJECT NO.</u>	<u>AMOUNT</u>
CAD Infrastructure Refresh	WBS# X-680096*	\$100,000.00

Communication is paramount to public safety and for the performance of our first responders. The Computer Aided Dispatch (CAD) system is a key component of the City's public safety solution enabling 911 call takers to document 911 calls for service and share critical information with first responders. This planned CAD Infrastructure Refresh Project is necessary for the City to maintain and support the City's computer and storage environment. This appropriation will allow for the purchase and replacement of CAD Infrastructure that is nearing end of life and/or end of support, to ensure this critical system continues to function with high availability. HITS will leverage cooperative contract(s) and/or existing enterprise contract(s) for the purchase of hardware, software and installation.

Fiscal Note:

No significant Fiscal Operating impact is anticipated because of this project.

Lisa Kent, Chief Information Officer
Houston Information Technology Services

Amount and Source of Funding:

\$100,000.00

FY25 Equipment Acquisition Consolidated Fund
Fund 1800

Contact Information:

Jane Wu, Deputy Director
HITS, DBM

Phone: (832)-393-0013

ATTACHMENTS:

Description

Signed Coversheet

Type

Signed Cover sheet



CITY OF HOUSTON - CITY COUNCIL

Meeting Date: 9/17/2024

ALL

Item Creation Date: 9/4/2024

HITS- CAD Infrastructure Refresh Appropriation

Agenda Item#: 35.

Background:

Specific Explanation:

The Chief Information Officer recommends that City Council approve an ordinance to appropriate \$100,000.00 from the Equipment Acquisition Consolidated Fund (1800) for the planned CAD Infrastructure Refresh Project for Houston Information Technology Services. This Project is budgeted in the approved FY2025 Capital Improvement Plan adopted by City Council.

The Project description with allocation amount is as follows:

<u>PROJECT</u>	<u>PROJECT NO.</u>	<u>AMOUNT</u>
CAD Infrastructure Refresh	WBS# X-680096*	\$100,000.00

Communication is paramount to public safety and for the performance of our first responders. The Computer Aided Dispatch (CAD) system is a key component of the City's public safety solution enabling 911 call takers to document 911 calls for service and share critical information with first responders. This planned CAD Infrastructure Refresh Project is necessary for the City to maintain and support the City's computer and storage environment. This appropriation will allow for the purchase and replacement of CAD Infrastructure that is nearing end of life and/or end of support, to ensure this critical system continues to function with high availability. HITS will leverage cooperative contract(s) and/or existing enterprise contract(s) for the purchase of hardware, software and installation.

Fiscal Note:

No significant Fiscal Operating impact is anticipated because of this project.

DocuSigned by:

44FF8FE8CCB7481...

Lisa Kent, Chief Information Officer
Houston Information Technology Services

Prior Council Action:

N/A

Amount and Source of Funding:

\$100,000.00 - FY25 Equipment Acquisition Consolidated Fund (1800)

Contact Information:

Jane Wu

Deputy Director
HITS, DBM
(832)-393-0013



ATTACHMENTS:

Description	Type
SAP Form A	Financial Information
FMBB doc	Financial Information
COF	Financial Information
Fiscal Note	Financial Information



CITY OF HOUSTON - CITY COUNCIL

Meeting Date: 9/24/2024

ALL

Item Creation Date:

Q26125.A3 - Aging and Caregiver Supportive Services-
ORDINANCE

Agenda Item#: 23.

Summary:

ORDINANCE approving and authorizing second amendment to extend contract term between City of Houston and (1) **ALPHA EYECARE ASSOCIATES PLLC**, (2) **CHINESE COMMUNITY CENTER**, (3) **ENTRAMED, INC. dba SENTIDO HEALTH**, (4) **HOME DELIVERY INCONTINENT SUPPLIES CO.**, (5) **MERC MEDICAL SUPPLY**, (6) **MONARCH ENDEAVORS LLC dba SYNERGY OF NORTHWEST HOUSTON**, (7) **TEXAS SOUTHERN UNIVERSITY**, (8) **UNIVERSITY OF TEXAS HEALTH SCIENCE CENTER AT HOUSTON**, (9) **MJC AUDIOLOGY CONSULTANT, LLC** (10) **INTERFAITH CARE PARTNERS**, (11) **ALZHEIMER'S DISEASE AND RELATED DISORDERS**, (12) **BAKERRIPLEY**, (13) **DINSMORE MEDICAL SYSTEMS LLC**, (14) **EVELYN RUBENSTEIN JEWISH COMMUNITY CENTER-VISITING**, (15) **HEARING AID EXPRESS**, (16) **HEIGHT HEARING AIDS, LLC**, (17) **MONTROSE COUNSELING CENTER**, (18) **PERRY LEE HOME HEALTH**, (19) **SYNERGY- KATY- HASELDEN HOMECARE LLC**, (20) **SYNERGY CONROE-MOSHER INITIATIVES INC**, for Aging and Caregiver Supportive Services to senior adults through the Harris County Area Agency on Aging for the Houston Health Department

Background:

P19-Q26125.A-3 - Approve an Ordinance authorizing a second amendment to the contracts between the City of Houston and (1) Alpha Eyecare Associates PLLC, (2) Chinese Community Center, (3) Entramed, Inc. Db a Sentido Health, (4) Home Delivery Incontinent Supplies Co., (5) MERC Medical Supply, (6) Monarch Endeavors LLC Db a Synergy of Northwest Houston, (7) Texas Southern University, (8) University of Texas Health Science Center at Houston, (9) MJC Audiology Consultant, LLC (10) Interfaith Care Partners, (11) Alzheimer's Disease and Related Disorders, (12) BakerRipley, (13) Dinsmore Medical Systems LLC, (14) Evelyn Rubenstein Jewish Community Center-Visiting, (15) Hearing Aid Express, (16) Height Hearing Aids, LLC, (17) Montrose Counseling Center, (18) Perry Lee Home Health, (19) Synergy- Katy- Haselden Homecare LLC, (20) Synergy Conroe- Mosher Initiatives Inc., (approved by Ord. #2018-1032 on December 18, 2018) to extend contracts term from September 30, 2024 to September 30, 2025 for aging and caregiver supportive services to senior adults through the Harris County Area Agency on Aging for the Houston Health Department.

Specific Explanation:

The Director of the Houston Health Department and the Chief Procurement Officer recommend that City Council approve an ordinance authorizing a second amendment to extend contracts term from September 30, 2024, to September 30, 2025, for contracts between the City of Houston and (1) Alpha Eyecare Associates PLLC, (2) Chinese Community Center, (3) Entramed, Inc. Dba Sentido Health, (4) Home Delivery Incontinent Supplies Co., (5) MERC Medical Supply, (6) Monarch Endeavors LLC Dba Synergy of Northwest Houston, (7) Texas Southern University, (8) University of Texas Health Science Center at Houston, (9) MJC Audiology Consultant, LLC (10) Interfaith Care Partners, (11) Alzheimer’s Disease and Related Disorders, (12) BakerRipley, (13) Dinsmore Medical Systems LLC, (14) Evelyn Rubenstein Jewish Community Center- Visiting, (15) Hearing Aid Express, (16) Height Hearing Aids, LLC, (17) Montrose Counseling Center, (18) Perry Lee Home Health, (19) Synergy- Katy- Haselden Homecare LLC, (20) Synergy Conroe-Mosher Initiatives for aging and caregiver supportive services to senior adults through the Harris County Area Agency on Aging (HCAAA) for the Houston Health Department (HHD).

On December 19, 2018, Ordinance No. 2018-1032 awarded (25) twenty-five contracts for three years with two one-year renewal options in the cumulative award amount of \$11,141,736.17. On March 31, 2021, Ordinance No. 2021-0235 increased the maximum award amount to \$11,497,808.00. On November 1, 2023, Ordinance No. 2023-924 increased the maximum award amount to \$25,759,544.17 and extended the contracts terms from September 30, 2023 to September 30, 2024. This amendment extends the contract terms for (20) twenty contracts to September 30, 2025, and allows for the completion of the RFP process and awarding new contracts.

Five of the twenty-five (25) contracts will not be extended and will expire on September 30, 2024, because one vendor was taken over by one of the other awarded vendors, the department is no longer using three vendors, and one vendor has been awarded a new contract.

The COVID-19 pandemic created a need for local and statewide compensation funding to address unexpected service gaps. These gaps included the need to provide additional supportive services, take on new referrals, deliver incontinent supplies and nutritional supplements, and increase caregiver information services, in-home services, and respite services, to name a few. Increased funding from the Older Americans Acts of 1965 enables contractors to meet the unexpected supportive service's elevated demand.

The program is grant-funded by the Older Americans Act of 1965 (OAA), and HCAAA coordinates supportive services for adults ages 60 and older in Harris County through a direct or community-based services delivery system.

Contract No.

Contractor

4600015184	Alpha Eyecare Associates PLLC
4600015186	Chinese Community Center
4600015197	Entramed Inc. dba Sentido Health
4600015221	Home Delivery Incontinent Supplies Co., Inc.
4600015199	MERC Medical Supply
4600015202	Monarch Endeavors LLC dba Synergy of Northwest Houston
4600015193	Texas Southern University

4600015194	University of Texas Health Science Center at Houston
4600015195	MPJ Audiology Consultant, LLC
4600015213	Interfaith Care Partners
4600015183	Alzheimer's Disease and Related Disorders
4600015185	BakerRipley
4600015187	Dinsmore Medical Systems LLC
4600015188	Evelyn Rubenstein Jewish Community Center- Visiting
4600015189	Hearing Aid Express
4600015190	Heights Hearing Aids, LLC
4600015192	Montrose Counseling Center
4600015196	Perry Lee Home Health
4600015201	Synergy-Katy Haselden Homecare LLC
4600015203	Synergy-Conroe- Mosher Initiatives Inc.

The scope of work requires the contractors to provide the following but not limited to:

Option 1: Support Services

Emergency Responses
Evidence-Based Interventions
Ombudsman Services

Option 2: Family Caregiver Support Services

Caregiver Information Services
Caregiver Respite Care-In Home

Option 3: Health Promotion Services

Dental Services Hearing Services
Vision Services
Medical Supply Provider
Mental Health Provider

Option 4: In-Home Services

Personal Assistance Visiting

M/WBE Participation:

M/WBE zero-percentage goal document approved by the Office of Business Opportunity.

Fiscal Note:

No Fiscal Note is required on grant items.

Jedediah Greenfield
Chief Procurement Officer
Finance/Strategic Procurement Division

Department Approval Authority

Prior Council Action:

Ordinance No. 2018-1032 passed on December 19, 2018
Ordinance No. 2021-0235 passed on March 31, 3021
Ordinance No. 2023-924 passed on November 1, 2023

Amount and Source of Funding:

NO FUDNING REQUIRE

Contact Information:

Name	Dept./Division	Phone No.:
Sheila Baker, Division Manager	Finance/SPD	(832) 393-8108
Carolyn Hanahan, Assistant Chief Policy Officer	Finance /SPD	(832) 393-9127
Jedediah Greenfield, Chief Procurement Officer	Finance/SPD	(832) 393-9126

ATTACHMENTS:

Description

Coversheet

Type

Signed Cover sheet



CITY OF HOUSTON - CITY COUNCIL

Meeting Date: 9/24/2024

ALL

Item Creation Date:

Q26125.A3 - Aging and Caregiver Supportive Services- ORDINANCE

Agenda Item#: 45.

Background:

P19-Q26125.A-3 - Approve an Ordinance authorizing a second amendment to the contracts between the City of Houston and (1) Alpha Eyecare Associates PLLC, (2) Chinese Community Center, (3) Entramed, Inc. Dba Sentido Health, (4) Home Delivery Incontinent Supplies Co., (5) MERC Medical Supply, (6) Monarch Endeavors LLC Dba Synergy of Northwest Houston, (7) Texas Southern University, (8) University of Texas Health Science Center at Houston, (9) MJC Audiology Consultant, LLC (10) Interfaith Care Partners, (11) Alzheimer’s Disease and Related Disorders, (12) BakerRipley, (13) Dinsmore Medical Systems LLC, (14) Evelyn Rubenstein Jewish Community Center- Visiting, (15) Hearing Aid Express, (16) Height Hearing Aids, LLC, (17) Montrose Counseling Center, (18) Perry Lee Home Health, (19) Synergy- Katy- Haselden Homecare LLC, (20) Synergy Conroe- Mosher Initiatives Inc., (approved by Ord. #2018-1032 on December 18, 2018) to extend contracts term from September 30, 2024 to September 30, 2025 for aging and caregiver supportive services to senior adults through the Harris County Area Agency on Aging for the Houston Health Department.

Specific Explanation:

The Director of the Houston Health Department and the Chief Procurement Officer recommend that City Council approve an ordinance authorizing a second amendment to extend contracts term from September 30, 2024, to September 30, 2025, for contracts between the City of Houston and (1) Alpha Eyecare Associates PLLC, (2) Chinese Community Center, (3) Entramed, Inc. Dba Sentido Health, (4) Home Delivery Incontinent Supplies Co., (5) MERC Medical Supply, (6) Monarch Endeavors LLC Dba Synergy of Northwest Houston, (7) Texas Southern University, (8) University of Texas Health Science Center at Houston, (9) MJC Audiology Consultant, LLC (10) Interfaith Care Partners, (11) Alzheimer’s Disease and Related Disorders, (12) BakerRipley, (13) Dinsmore Medical Systems LLC, (14) Evelyn Rubenstein Jewish Community Center- Visiting, (15) Hearing Aid Express, (16) Height Hearing Aids, LLC, (17) Montrose Counseling Center, (18) Perry Lee Home Health, (19) Synergy- Katy- Haselden Homecare LLC, (20) Synergy Conroe- Mosher Initiatives for aging and caregiver supportive services to senior adults through the Harris County Area Agency on Aging (HCAAA) for the Houston Health Department (HHD).

On December 19, 2018, Ordinance No. 2018-1032 awarded (25) twenty-five contracts for three years with two one-year renewal options in the cumulative award amount of \$11,141,736.17. On March 31, 2021, Ordinance No. 2021-0235 increased the maximum award amount to \$11,497,808.00. On November 1, 2023, Ordinance No. 2023-924 increased the maximum award amount to \$25,759,544.17 and extended the contracts terms from September 30, 2023 to September 30, 2024. This amendment extends the contract terms for (20) twenty contracts to September 30, 2025, and allows for the completion of the RFP process and awarding new contracts.

Five of the twenty-five (25) contracts will not be extended and will expire on September 30, 2024, because one vendor was taken over by one of the other awarded vendors, the department is no longer using three vendors, and one vendor has been awarded a new contract.

The COVID-19 pandemic created a need for local and statewide compensation funding to address unexpected service gaps. These gaps included the need to provide additional supportive services, take on new referrals, deliver incontinent supplies and nutritional supplements, and increase caregiver information services, in-home services, and respite services, to name a few. Increased funding from the Older Americans Acts of 1965 enables contractors to meet the unexpected supportive service’s elevated demand.

The program is grant-funded by the Older Americans Act of 1965 (OAA), and HCAAA coordinates supportive services for adults ages 60 and older in Harris County through a direct or community-based services delivery system.

Contract No.	Contractor
4600015184	Alpha Eyecare Associates PLLC
4600015186	Chinese Community Center
4600015197	Entramed Inc. dba Sentido Health
4600015221	Home Delivery Incontinent Supplies Co., Inc.
4600015199	MERC Medical Supply
4600015202	Monarch Endeavors LLC dba Synergy of Northwest Houston

- 4600015193 Texas Southern University
- 4600015194 University of Texas Health Science Center at Houston
- 4600015195 MPJ Audiology Consultant, LLC
- 4600015213 Interfaith Care Partners
- 4600015183 Alzheimer's Disease and Related Disorders
- 4600015185 BakerRipley
- 4600015187 Dinsmore Medical Systems LLC
- 4600015188 Evelyn Rubenstein Jewish Community Center- Visiting
- 4600015189 Hearing Aid Express
- 4600015190 Heights Hearing Aids, LLC
- 4600015192 Montrose Counseling Center
- 4600015196 Perry Lee Home Health
- 4600015201 Synergy-Katy Haselden Homecare LLC
- 4600015203 Synergy-Conroe- Mosher Initiatives Inc.

The scope of work requires the contractors to provide the following but not limited to:

Option 1: Support Services

- Emergency Responses
- Evidence-Based Interventions
- Ombudsman Services

Option 2: Family Caregiver Support Services

- Caregiver Information Services
- Caregiver Respite Care-In Home

Option 3: Health Promotion Services

- Dental Services Hearing Services
- Vision Services

- Medical Supply Provider
- Mental Health Provider

Option 4: In-Home Services

- Personal Assistance Visiting

M/WBE Participation:

M/WBE zero-percentage goal document approved by the Office of Business Opportunity.

Fiscal Note:

There is no impact to the fiscal budget or no additional spending authority. Therefore, no Fiscal Note is required as stated in the Financial Policies.

9/13/2024

DocuSigned by:

 6121834A077C41A...

 Jedediah Greenfield
 Chief Procurement Officer
 Finance/Strategic Procurement Division

DocuSigned by:

 A8219D332CF4498...

 Department Approval Authority

9/13/2024

Prior Council Action:

- Ordinance No. 2018-1032 passed on December 19, 2018
- Ordinance No. 2021-0235 passed on March 31, 2021
- Ordinance No. 2023-924 passed on November 1, 2023

Amount and Source of Funding:

NO FUDNING REQUIRE

Contact Information:

Name	Dept./Division	Phone No.:
Sheila Baker, Division Manager	Finance/SPD	(832) 393-8108
Carolyn Hanahan, Assistant Chief Policy Officer	Finance /SPD	(832) 393-9127
Jedediah Greenfield, Chief Procurement Officer	Finance/SPD	(832) 393-9126



CITY OF HOUSTON - CITY COUNCIL

Meeting Date: 9/24/2024

ALL

Item Creation Date: 9/6/2024

Doc1047861584 - Financial Advisory Services (Masterson Advisor, LLC) - ORDINANCE

Agenda Item#: 24.

Summary:

ORDINANCE approving and awarding Professional Services Agreement between City of Houston and **MASTERSON ADVISORS, LLC** for Financial Advisory Services for the Finance Department; providing a maxim contract amount - 3 Years with 2 one-year options - \$4,845,000.00 - Enterprise and Other Funds

Background:

Request for Proposals received June 6, 2024, for P15-Doc1047861584 - Approve an ordinance awarding a contract to Masterson Advisors, LLC in the maximum contract amount of \$4,845,000.00 for financial advisory services for three-year with two one-year options for the Finance Department.

Specific Explanation:

The Director of the Finance Department and the Chief Procurement Officer recommend that City Council approve an ordinance awarding a **three-year contract, with two one-year options** to **Masterson Advisors, LLC** in the maximum contract amount not to exceed **\$4,845,000.00** for financial advisory services for the Finance Department. The Director of Finance may terminate this contract at any time upon thirty (30) days written notice to the contractor.

The scope of work requires the contractor to provide financial advisory services including, but not limited to, new-money and refunding bonds sold on a competitive and negotiated basis, pre-pricing and post-pricing analysis of competitive and negotiated sales, refunding analysis and other debt restructurings, managing the process for securing and negotiating new credit facilities, re-investment analysis, development of debt management policies and procedures, monitoring of secondary-market activities, training, assistance in the procurement of debt management-related services, and analysis of debt management-related fees.

The Request for Proposals (RFP) was advertised in accordance with the requirements of the state of Texas bid laws and as a result, proposals were received from Frasca Associates, LLC, Masterson Advisors, LLC, and PFM Financial Advisors, LLC. The evaluation committee consisted of employees from the Finance Department, Houston Airport System, the City Controller's Office, Houston Public Works, and Houston First Corporation.

The proposals were evaluated based upon the following criteria:

1. Responsiveness
2. Technical Competence
3. Price Proposal

Masterson Advisors, LLC received the highest overall score and was deemed the most qualified to perform the required services as outlined in the RFP.

M/WBE Subcontracting:

The RFP solicitation was advertised with a **6%** goal for M/WBE participation. Masterson Advisors, LLC has submitted a plan indicating that it will utilize itself for 3% at the prime level and will utilize the below-named company as its certified M/WBE subcontractor.

Vendor Name	Type of Work	Percentage
Masterson Advisors, LLC	Financial Advisor	3%
TKG & Associates	Co-Financial Advisor	12%
Total		15%

Pay or Play Program:

The proposed contract requires compliance with the City's 'Pay or Play' ordinance regarding health benefits for employees of City contractors. In this case, the contractor will provide health benefits to eligible employees in compliance with City policy.

Hire Houston First (HHF):

The proposed contract requires compliance with the City's 'Hire Houston First' ordinance that promotes economic opportunity for Houston businesses and supports job creation. In this case, Masterson Advisors, LLC is a designated HHF company; however, they were the successful awardee without application of the HHF preference.

Fiscal Note:

Funding for this item is included in the FY25 Adopted Budget. Therefore, no Fiscal Note is required as stated in the Financial Policies.

Jedediah Greenfield, Chief Procurement Officer

Department Approval Authority

Estimated Spending Authority:			
Department	FY2025	Out Years	Total
General Gov't	\$293,000.00	\$1,172,000.00	\$1,465,000.00
Houston Airport System	\$293,000.00	\$1,172,000.00	\$1,465,000.00
Houston Public Works	\$293,000.00	\$1,172,000.00	\$1,465,000.00
Convention and Entertainment	\$90,000.00	\$360,000.00	\$450,000.00
Total	\$969,000.00	\$3,876,000.00	\$4,845,000.00

Amount and Source of Funding:

\$1,465,000.00 – General Debt Service Admin Fund (3000)
\$1,465,000.00 – HAS Revenue Fund (8001)
\$1,465,000.00 – HPW Combined Utility System Gen Pur Fund (8305)
\$450,000.00 – C&E – Civic Center Facility Revenue Fund (8601)
\$4,845,000.00 - Total

Contact Information:

Alma Tamborello, Deputy Director	Finance/SPD (832)393-9099
Adeola Otukoya, Division Manager	Finance/SPD (832) 393-8786
Candice Gambrell, Assistant Director	Finance/SPD (832) 393-9129
Jedediah Greenfield, Chief Procurement Officer	Finance/SPD (832)393-9126

ATTACHMENTS:

Description	Type
Coversheet	Signed Cover sheet
Coversheet	Signed Cover sheet



CITY OF HOUSTON - CITY COUNCIL

Meeting Date:

ALL

Item Creation Date: 9/6/2024

Doc1047861584 - Financial Advisory Services (Masterson Advisor, LLC) - ORDINANCE

Agenda Item#:

Background:

Request for Proposals received June 6, 2024, for P15-Doc1047861584 - Approve an ordinance awarding a contract to Masterson Advisors, LLC in the maximum contract amount of \$4,485,000.00 for financial advisory services for three-year with two one-year options for the Finance Department.

Specific Explanation:

The Director of the Finance Department and the Chief Procurement Officer recommend that City Council approve an ordinance awarding a **three-year contract, with two one-year options** to **Masterson Advisors, LLC** in the maximum contract amount not to exceed **\$4,845,000.00** for financial advisory services for the Finance Department. The Director of Finance may terminate this contract at any time upon thirty (30) days written notice to the contractor.

The scope of work requires the contractor to provide financial advisory services including, but not limited to, new-money and refunding bonds sold on a competitive and negotiated basis, pre-pricing and post-pricing analysis of competitive and negotiated sales, refunding analysis and other debt restructurings, managing the process for securing and negotiating new credit facilities, re-investment analysis, development of debt management policies and procedures, monitoring of secondary-market activities, training, assistance in the procurement of debt management-related services, and analysis of debt management-related fees.

The Request for Proposals (RFP) was advertised in accordance with the requirements of the state of Texas bid laws and as a result, proposals were received from Frasca Associates, LLC, Masterson Advisors, LLC, and PFM Financial Advisors, LLC. The evaluation committee consisted of employees from the Finance Department, Houston Airport System, the City Controller's Office, Houston Public Works, and Houston First Corporation.

The proposals were evaluated based upon the following criteria:

1. Responsiveness
2. Technical Competence
3. Price Proposal

Masterson Advisors, LLC received the highest overall score and was deemed the most qualified to perform the required services as outlined in the RFP.

M/WBE Subcontracting:

The RFP solicitation was advertised with a **6%** goal for M/WBE participation. Masterson Advisors, LLC has submitted a plan indicating that it will utilize itself for 3% at the prime level and will utilize the below-named company as its certified M/WBE subcontractor.

Vendor Name	Type of Work	Percentage
Masterson Advisors, LLC	Financial Advisor	3%
TKG & Associates	Co-Financial Advisor	12%
Total		15%

Pay or Play Program:

The proposed contract requires compliance with the City's 'Pay or Play' ordinance regarding health benefits for employees of City contractors. In this case, the contractor will provide health benefits to eligible employees in compliance with City policy.

Hire Houston First (HHF):

The proposed contract requires compliance with the City's 'Hire Houston First' ordinance that promotes economic opportunity for Houston businesses and supports job creation. In this case, Masterson Advisors, LLC is a designated HHF company; however, they were the successful awardee without application of the HHF preference.

Fiscal Note:

Funding for this item is included in the FY25 Adopted Budget. Therefore, no Fiscal Note is required as stated in the Financial Policies.

9/11/2024

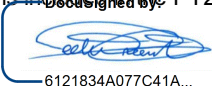
6121834A077C41A...

Jedediah Greenfield, Chief Procurement Officer

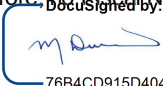
76B4CD915D404C7...

Department Approval Authority

9/16/2024

DS

Estimated Spending Authority:			
Department	FY2025	Out Years	Total
General Gov't	\$293,000.00	\$1,172,000.00	\$1,465,000.00
Houston Airport System	\$293,000.00	\$1,172,000.00	\$1,465,000.00
Houston Public Works	\$293,000.00	\$1,172,000.00	\$1,465,000.00
Convention and Entertainment	\$90,000.00	\$360,000.00	\$450,000.00
Total	\$969,000.00	\$3,876,000.00	\$4,845,000.00

Amount and Source of Funding:

- \$1,465,000.00 – General Debt Service Admin Fund (3000)
- \$1,465,000.00 – HAS Revenue Fund (8001)
- \$1,465,000.00 – HPW Combined Utility System Gen Pur Fund (8305)
- \$450,000.00 – C&E – Civic Center Facility Revenue Fund (8601)
- \$4,845,000.00 - Total**

Contact Information:

- Alma Tamborello, Deputy Director Finance/SPD (832)393-9099
- Adeola Otukoya, Division Manager Finance/SPD (832) 393-8786
- Candice Gambrell, Assistant Director Finance/SPD (832) 393-9129
- Jedediah Greenfield, Chief Procurement Officer Finance/SPD (832)393-9126

ATTACHMENTS:

Description	Type
Ownership Form	Backup Material
Clear Tax Report	Backup Material
CIQ Endorsement	Backup Material
COF - Finance	Financial Information
MWBE Contract Specific Request	Backup Material
Secretary of State1	Backup Material
Secretary of State2	Backup Material
Drug Forms - Masterson	Backup Material
Certificate of Insurance	Backup Material
POP 1	Backup Material
POP 2	Backup Material
POP 3	Backup Material
MWBE Participating Plan	Backup Material



CITY OF HOUSTON - CITY COUNCIL

Meeting Date:

ALL

Item Creation Date: 9/6/2024

Doc1047861584 - Financial Advisory Services (Masterson Advisor, LLC) - ORDINANCE

Agenda Item#:

Background:

Request for Proposals received June 6, 2024, for P15-Doc1047861584 - Approve an ordinance awarding a contract to Masterson Advisors, LLC in the maximum contract amount of \$4,485,000.00 for financial advisory services for three-year with two one-year options for the Finance Department.

Specific Explanation:

The Director of the Finance Department and the Chief Procurement Officer recommend that City Council approve an ordinance awarding a **three-year contract, with two one-year options** to **Masterson Advisors, LLC** in the maximum contract amount not to exceed **\$4,845,000.00** for financial advisory services for the Finance Department. The Director of Finance may terminate this contract at any time upon thirty (30) days written notice to the contractor.

The scope of work requires the contractor to provide financial advisory services including, but not limited to, new-money and refunding bonds sold on a competitive and negotiated basis, pre-pricing and post-pricing analysis of competitive and negotiated sales, refunding analysis and other debt restructurings, managing the process for securing and negotiating new credit facilities, re-investment analysis, development of debt management policies and procedures, monitoring of secondary-market activities, training, assistance in the procurement of debt management-related services, and analysis of debt management-related fees.

The Request for Proposals (RFP) was advertised in accordance with the requirements of the state of Texas bid laws and as a result, proposals were received from Frasca Associates, LLC, Masterson Advisors, LLC, and PFM Financial Advisors, LLC. The evaluation committee consisted of employees from the Finance Department, Houston Airport System, the City Controller's Office, Houston Public Works, and Houston First Corporation.

The proposals were evaluated based upon the following criteria:

1. Responsiveness
2. Technical Competence
3. Price Proposal

Masterson Advisors, LLC received the highest overall score and was deemed the most qualified to perform the required services as outlined in the RFP.

M/WBE Subcontracting:

The RFP solicitation was advertised with a **6%** goal for M/WBE participation. Masterson Advisors, LLC has submitted a plan indicating that it will utilize itself for 3% at the prime level and will utilize the below-named company as its certified M/WBE subcontractor.

Vendor Name	Type of Work	Percentage
Masterson Advisors, LLC	Financial Advisor	3%
TKG & Associates	Co-Financial Advisor	12%
Total		15%

Pay or Play Program:

The proposed contract requires compliance with the City's 'Pay or Play' ordinance regarding health benefits for employees of City contractors. In this case, the contractor will provide health benefits to eligible employees in compliance with City policy.

Hire Houston First (HHF):

The proposed contract requires compliance with the City's 'Hire Houston First' ordinance that promotes economic opportunity for Houston businesses and supports job creation. In this case, Masterson Advisors, LLC is a designated HHF company; however, they were the successful awardee without application of the HHF preference.

Fiscal Note:

Funding for this item is included in the FY25 Adopted Budget. Therefore, no Fiscal Note is required as stated in the Financial Policies.

9/11/2024

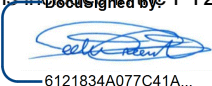

6121834A077C41A...

Jedediah Greenfield, Chief Procurement Officer

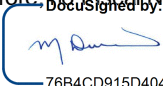

76B4CD915D404C7...

Department Approval Authority

9/16/2024

ds
at

Estimated Spending Authority:			
Department	FY2025	Out Years	Total
General Gov't	\$293,000.00	\$1,172,000.00	\$1,465,000.00
Houston Airport System	\$293,000.00	\$1,172,000.00	\$1,465,000.00
Houston Public Works	\$293,000.00	\$1,172,000.00	\$1,465,000.00
Convention and Entertainment	\$90,000.00	\$360,000.00	\$450,000.00
Total	\$969,000.00	\$3,876,000.00	\$4,845,000.00

Amount and Source of Funding:

- \$1,465,000.00 – General Debt Service Admin Fund (3000)
- \$1,465,000.00 – HAS Revenue Fund (8001)
- \$1,465,000.00 – HPW Combined Utility System Gen Pur Fund (8305)
- \$450,000.00 – C&E – Civic Center Facility Revenue Fund (8601)
- \$4,845,000.00 - Total**

Contact Information:

- Alma Tamborello, Deputy Director Finance/SPD (832)393-9099
- Adeola Otukoya, Division Manager Finance/SPD (832) 393-8786
- Candice Gambrell, Assistant Director Finance/SPD (832) 393-9129
- Jedediah Greenfield, Chief Procurement Officer Finance/SPD (832)393-9126

ATTACHMENTS:

Description	Type
Ownership Form	Backup Material
Clear Tax Report	Backup Material
CIQ Endorsement	Backup Material
COF - Finance	Financial Information
MWBE Contract Specific Request	Backup Material
Secretary of State1	Backup Material
Secretary of State2	Backup Material
Drug Forms - Masterson	Backup Material
Certificate of Insurance	Backup Material
POP 1	Backup Material
POP 2	Backup Material
POP 3	Backup Material
MWBE Participating Plan	Backup Material



CITY OF HOUSTON - CITY COUNCIL

Meeting Date: 9/24/2024

ALL

Item Creation Date: 9/6/2024

T28853.A2 - Disaster Debris Monitoring Services (Thompson Consulting Services, LLC) - ORDINANCE

Agenda Item#: 25.

Summary:

PULLED - This item will not be considered on Wednesday September 25

ORDINANCE amending Ordinance No. 2022-0678 to increase maximum contract amount for Professional Services Agreement between City of Houston and **THOMPSON CONSULTING SERVICES, LLC.**, for continued Disaster Debris Monitoring Services for the Solid Waste Department - \$16,000,000.00 - General Fund

Background:

P74-T28853.A2 - Approve an amending ordinance to Ordinance No. 2022-678 (approved on September 7, 2022) to increase the maximum contract amount from \$5,000,000.00 to \$21,000,000.00 for Contract No. 4600015771 between the City of Houston and Thompson Consulting Services, LLC for continued disaster debris monitoring services for the Solid Waste Management Department.

Specific Explanation:

The Director of the Solid Waste Management Department (SWMD) and the Chief Procurement Officer recommend that City Council approve an amending ordinance to increase the maximum contract amount from **\$5,000,000.00 to \$21,000,000.00** for the contract between the City of Houston and **Thompson Consulting Services, LLC** for continued disaster debris monitoring services for the Solid Waste Management Department.

The pre-positioned contract was awarded on June 19, 2019, by Ordinance No. 2019-476. By Ordinance No. 2022-678 (approved on September 7, 2022), the Thompson Consulting Services, LLC contract was activated for a three-year term with two one-year options to renew and was given a maximum contract amount of \$5,000,000.00. As of August 20, 2024, total invoices received from Thompson Consulting Services, LLC for the Derecho Storm and Hurricane Beryl amount to \$3,833,548.70. SWMD is increasing the maximum contract amount and adding additional spending authority in response to the debris cleanup efforts caused by Hurricane Beryl. This increase is expected to carry SWMD through the initial term of the contract, which ends on September 8, 2025.

The scope of work requires the Contractor to provide debris monitoring services to assist the City with monitoring the operations of the Debris Management Contractor(s) (DMC) in disaster debris removal and disposal. The Contractor shall observe, monitor and document the DMC's removal, processing, and disposal operations, including maintaining documentation regarding debris types, quantities, reduction methods, and pick-up and disposal locations to certify all debris collection and disposal services comply with all applicable law, including Federal Emergency Management Agency (FEMA) regulations, policies and guidelines to maximize reimbursements from FEMA and other federal, state and local agencies.

MWBE Participation:

The contract was awarded with a 39.99% M/WBE participation goal. Thompson Consulting Services, LLC is currently achieving 70.24% of the required MWBE participation on the contract.

Disaster Recovery Note:

This item is related to the impact of the May 2024 Derecho storm DR-4781 and Hurricane Beryl DR-4798, and it is the City's intent to seek reimbursement from FEMA and other eligible sources for such expenditures.

Fiscal Note:

Funding for this item is included in the FY25 Adopted Budget. Therefore, no Fiscal note is required as stated in the Financial Policies.

Estimated Spending Authority			
Department	FY25	Out-Years	Award Amount
Solid Waste Management Department	\$15,000,000.00	\$1,000,000.00	\$16,000,000.00

Prior Council Action:

Ordinance No. 2019-476 - approved by City Council on June 19, 2019
Ordinance No. 2022-678 - approved by City Council on September 7, 2022

Amount and Source of Funding:

\$16,000,000.00
General Fund
Fund 1000

Contact Information:

Name	Dept/Division	Phone No.
Barbara Fisher, Division Manager	FIN/ SPD	(832) 393-8722
Candice Gambrell, Assistant Director	FIN/SPD	(832) 393-9129
Jedediah Greenfield, Chief Procurement Officer	FIN/SPD	(832) 393-9126

ATTACHMENTS:

Description	Type
Coversheet	Signed Cover sheet



CITY OF HOUSTON - CITY COUNCIL

Meeting Date:

ALL

Item Creation Date: 9/6/2024

T28853.A2 - Disaster Debris Monitoring Services (Thompson Consulting Services, LLC) -
ORDINANCE

Agenda Item#:

Summary:

AN ORDINANCE AMENDING ORDINANCE NO. 2022-0678 TO INCREASE THE MAXIMUM CONTRACT AMOUNT FOR THE PROFESSIONAL SERVICES AGREEMENT BETWEEN THE CITY OF HOUSTON AND THOMPSON CONSULTING SERVICES, LLC., FOR CONTINUED DISASTER DEBRIS MONITORING SERVICES FOR THE SOLID WASTE DEPARTMENT; CONTAINING PROVISIONS RELATING TO THE SUBJECT; AND DECLARING AN EMERGENCY.

Background:

P74-T28853.A2 - Approve an amending ordinance to Ordinance No. 2022-678 (approved on September 7, 2022) to increase the maximum contract amount from \$5,000,000.00 to \$21,000,000.00 for Contract No. 4600015771 between the City of Houston and Thompson Consulting Services, LLC for continued disaster debris monitoring services for the Solid Waste Management Department.

Specific Explanation:

The Director of the Solid Waste Management Department (SWMD) and the Chief Procurement Officer recommend that City Council approve an amending ordinance to increase the maximum contract amount from **\$5,000,000.00 to \$21,000,000.00** for the contract between the City of Houston and **Thompson Consulting Services, LLC** for continued disaster debris monitoring services for the Solid Waste Management Department.

The pre-positioned contract was awarded on June 19, 2019, by Ordinance No. 2019-476. By Ordinance No. 2022-678 (approved on September 7, 2022), the Thompson Consulting Services, LLC contract was activated for a three-year term with two one-year options to renew and was given a maximum contract amount of \$5,000,000.00. As of August 20, 2024, total invoices received from Thompson Consulting Services, LLC for the Derecho Storm and Hurricane Beryl amount to \$3,833,548.70. SWMD is increasing the maximum contract amount and adding additional spending authority in response to the debris cleanup efforts caused by Hurricane Beryl. This increase is expected to carry SWMD through the initial term of the contract, which ends on September 8, 2025.

The scope of work requires the Contractor to provide debris monitoring services to assist the City with monitoring the operations of the Debris Management Contractor(s) (DMC) in disaster debris removal and disposal. The Contractor shall observe, monitor and document the DMC's removal, processing, and disposal operations, including maintaining documentation regarding debris types, quantities, reduction methods, and pick-up and disposal locations to certify all debris collection and disposal services comply with all applicable law, including Federal Emergency Management Agency (FEMA) regulations, policies and guidelines to maximize reimbursements from FEMA and other federal, state and local agencies.

MWBE Participation:

The contract was awarded with a 39.99% MWBE participation goal. Thompson Consulting Services, LLC is currently achieving 70.24% of the required MWBE participation on the contract.

Disaster Recovery Note:

This item is related to the impact of the May 2024 Derecho storm DR-4781 and Hurricane Beryl DR-4798, and it is the City's intent to seek reimbursement from FEMA and other eligible sources for such expenditures.

Fiscal Note:

Funding for this item is included in the FY25 Adopted Budget. Therefore, no Fiscal note is required as stated in the Financial Policies.

DocuSigned by:

6121834A077C41A...

Jedediah Greenfield
Chief Procurement Officer

DocuSigned by:

7F55A496448148A...

Department Approval Authority

9/12/2024

Estimated Spending Authority			
Department	FY25	Out-Years	Award Amount
Solid Waste Management Department	\$15,000,000.00	\$1,000,000.00	\$16,000,000.00

Prior Council Action:

Ordinance No. 2019-476 - approved by City Council on June 19, 2019
 Ordinance No. 2022-678 - approved by City Council on September 7, 2022

Amount and Source of Funding:

\$16,000,000.00 – General Fund (1000)

Contact Information:

Name	Dept/Division	Phone No.
Barbara Fisher, Division Manager	FIN/ SPD	(832) 393-8722
Candice Gambrell, Assistant Director	FIN/SPD	(832) 393-9129
Jedediah Greenfield, Chief Procurement Officer	FIN/SPD	(832) 393-9126

ATTACHMENTS:

Description	Type
Ord. No. 2019-476	Backup Material
Ord. No. 2022-678	Backup Material
RCA Ord. No. 2019-476	Backup Material
RCA Ord. No. 2022-678	Backup Material
Fully Executed Contract 4600015771	Backup Material
Notice to Proceed 9.9.2022 Ord. No. 2022-678	Backup Material
Clear Tax Report	Backup Material
Form A	Financial Information
MWBE Verification	Backup Material
Ordinance	Signed Cover sheet



CITY OF HOUSTON - CITY COUNCIL

Meeting Date: 9/24/2024

ALL

Item Creation Date:

WS983346726 - Cyberlab Laboratory Information System
Service (Aspyra, LLC) - ORDINANCE

Agenda Item#: 26.

Summary:

ORDINANCE approving and authorizing Sole Source Agreement between City of Houston and **ASPYRA, LLC** for Hardware, Software, Maintenance, and Support Services for Cyberlab Laboratory Information System for the Houston Health Department; providing a maximum contract amount - 1 Year with 4 one-year terms - \$504,468.52 - Laboratory Services Fund

Background:

Sole Source (P35-WS983346726) - Approve an ordinance authorizing a sole source agreement between the City of Houston and Aspyra, LLC in an amount not to exceed \$504,468.52 for hardware, software, maintenance, and support services for the Cyberlab Laboratory Information System for a one-year term with four one-year automatic renewals for the Houston Health Department (HHD).

Specific Explanation:

The Director of the Houston Health Department and the Chief Procurement Officer recommend that the City Council approve an ordinance authorizing a sole source agreement between the City of Houston and **Aspyra, LLC** in an amount not to exceed **\$504,468.52** for the purchase of hardware, software, equipment maintenance, and support services for the Houston Health Department's Cyberlab testing process system. The contract is for a **one-year term with four one-year automatic renewals** and is effective on the countersignature date.

The Cyberlab system is used to track HHD laboratory testing. According to this agreement, Aspyra will provide the following services: 1) enhance, adapt, modify, and maintain the software; 2) repair or replace specified parts; and 3) all repairs necessary to keep the equipment in good operating condition by the applicable functional specifications. The HHD laboratory performs approximately 185 different types of tests, which are utilized by clinics, hospitals, government agencies, and public health surveillance initiatives for the Houston Health Department.

This recommendation is made pursuant to subsection 252.022(a)(7) of the Texas Local Government Code, which provides that "a procurement of items that are available from only one source..." is exempt from the competitive requirements for purchases.

MWBE Participation:

The Sole Source agreement has a 0% M/WBE participation goal approved by the Office of Business Opportunity.

Pay or Play:

The proposed contracts requires compliance with the City’s Pay or Play ordinance regarding health benefits for employees of City contractors. In this case, the contractor provides health benefits to eligible employees in compliance with City policy.

Hire Houston First:

This procurement requires compliance with the City’s “Hire Houston First” ordinance. Bids/proposals were not solicited because the department is utilizing a sole source vendor for this purchase.

Fiscal Note:

Funding for this item is included in the FY2025 Adopted Budget. Therefore, no Fiscal Note is required as stated in the Financial Policies.

Jedediah Greenfield, Chief Procurement Officer
Finance/Strategic Procurement Division

Department Approval Authority

Estimated Spending Authority			
Department	FY2025	Out-Years	Award Amount
Houston Health Department	\$87,130.61	\$417,337.91	\$504,468.52

Amount and Source of Funding:

\$504,468.52

Laboratory Services Fund
Fund No.: 2008

Contact Information:

Sheila Baker, Division Manager	Finance/SPD	(832)393-8109
Carolyn Hanahan, Assistant Chief Policy Officer	Finance/SPD	(832)393-9127
Jedediah Greenfield, Chief Procurement Officer	Finance/SPD	(832)393-9126

ATTACHMENTS:

Description

Coversheet

Type

Signed Cover sheet



CITY OF HOUSTON - CITY COUNCIL

Meeting Date:

ALL

Item Creation Date:

WS983346726 - Cyberlab Laboratory Information System Service (Aspyra, LLC) -
ORDINANCE

Agenda Item#:

Summary:

AN ORDINANCE APPROVING AND AUTHORIZING A SOLE SOURCE AGREEMENT BETWEEN THE CITY OF HOUSTON AND ASPYRA, LLC FOR HARDWARE, SOFTWARE, MAINTENANCE, AND SUPPORT SERVICES FOR THE CYBERLAB LABORATORY INFORMATION SYSTEM FOR THE HOUSTON HEALTH DEPARTMENT; PROVIDING A MAXIMUM CONTRACT AMOUNT; CONTAINING PROVISIONS RELATING TO THE SUBJECT; AND DECLARING AN EMERGENCY.

Background:

Sole Source (P35-WS983346726) - Approve an ordinance authorizing a sole source agreement between the City of Houston and Aspyra, LLC in an amount not to exceed \$504,468.52 for hardware, software, maintenance, and support services for the Cyberlab Laboratory Information System for a one-year term with four one-year automatic renewals for the Houston Health Department (HHD).

Specific Explanation:

The Director of the Houston Health Department and the Chief Procurement Officer recommend that the City Council approve an ordinance authorizing a sole source agreement between the City of Houston and **Aspyra, LLC** in an amount not to exceed **\$504,468.52** for the purchase of hardware, software, equipment maintenance, and support services for the Houston Health Department's Cyberlab testing process system. The contract is for a **one-year term with four one-year automatic renewals** and is effective on the countersignature date.

The Cyberlab system is used to track HHD laboratory testing. According to this agreement, Aspyra will provide the following services: 1) enhance, adapt, modify, and maintain the software; 2) repair or replace specified parts; and 3) all repairs necessary to keep the equipment in good operating condition by the applicable functional specifications. The HHD laboratory performs approximately 185 different types of tests, which are utilized by clinics, hospitals, government agencies, and public health surveillance initiatives for the Houston Health Department.

This recommendation is made pursuant to subsection 252.022(a)(7) of the Texas Local Government Code, which provides that "a procurement of items that are available from only one source..." is exempt from the competitive requirements for purchases.

MWBE Participation:

The Sole Source agreement has a 0% MWBE participation goal approved by the Office of Business Opportunity.

Pay or Play:

The proposed contracts requires compliance with the City's Pay or Play ordinance regarding health benefits for employees of City contractors. In this case, the contractor provides health benefits to eligible employees in compliance with City policy.

Hire Houston First:

This procurement requires compliance with the City's "Hire Houston First" ordinance. Bids/proposals were not solicited because the department is utilizing a sole source vendor for this purchase.

Fiscal Note:

Funding for this item is included in the FY2025 Adopted Budget. Therefore, no Fiscal Note is required as stated in the Financial Policies.

9/4/2024

DocuSigned by:

6121834A077C41A...

Jerediah Greenfield, Chief Procurement Officer
Finance/Strategic Procurement Division

DocuSigned by:

A8219D332CF4498...

Department Approval Authority

9/4/2024

Estimated Spending Authority			
Department	FY2025	Out-Years	Award Amount
Houston Health Department	\$87,130.61	\$417,337.91	\$504,468.52

Amount and Source of Funding:

\$504,468.52

Laboratory Services Fund

Fund No.: 2008

Contact Information:

Sheila Baker, Division Manager	Finance/SPD	(832)393-8109
Carolyn Hanahan, Assistant Chief Policy Officer	Finance/SPD	(832)393-9127
Jedediah Greenfield, Chief Procurement Officer	Finance/SPD	(832)393-9126

ATTACHMENTS:

Description	Type
ASPYRA Signed Agreement	Backup Material
POP Forms 1	Backup Material
POP Forms 2	Backup Material
Conflict of Interest Questionnaire	Backup Material
Drug Forms	Backup Material
Sole Source Justification	Backup Material
COF	Backup Material
Form A	Backup Material
OA 4600018391	Backup Material
PR 10329590	Backup Material
MWBE Wavier	Backup Material
COI	Backup Material
Affidavit of Ownership and Control	Backup Material
TAX REPORT	Backup Material



CITY OF HOUSTON - CITY COUNCIL

Meeting Date: 9/24/2024

Item Creation Date:

WS1188918296 - Airport Concessions Loyalty Rewards Program
(Thanks Again, LLC, DBA GlidePathCX) - ORDINANCE

Agenda Item#: 27.

Summary:

ORDINANCE approving and authorizing Sole Source Agreement between City of Houston and **THANKS AGAIN, LLC d/b/a GLIDEPATHCX** for Airport Concessions Loyalty Rewards Program for the Houston Airport System; providing a maximum contract amount - 2 Years with 1 one-year option - \$1,200,000.00 - Enterprise Fund

Background:

Sole Source (S19-WS1188918296) – Approve an ordinance awarding a sole source agreement with Thanks Again, LLC d/b/a GlidePathCX for the maximum contract amount of \$1,200,000.00 for the airport concessions loyalty rewards program for a two-year (2) term with one (1) one-year option for the Houston Airport System (HAS).

Specific Explanation

The Director of the Houston Airport System and the Chief Procurement Officer recommend that City Council approve an ordinance awarding a sole source contract for **a two-year (2) term with one (1) one-year option** to **Thanks Again, LLC d/b/a GlidePathCX** in an amount not to exceed **\$1,200,000.00** for Airport Concessions Loyalty Rewards Program for the Houston Airport System.

The Houston Airport System endeavors to increase passengers' awareness and patronage of available concessions options for parking, shopping, and dining at both Bush Intercontinental and William P. Hobby Airports. GlidePathCX by Thank Again, LLC is a proprietary program that allows airports to develop loyalty rewards for customer purchases while on airport property (parking and in-terminal sales) and in day-to-day consumer spending with airport vendors and other participating businesses. The result is an increase in non-aeronautical revenue for both commercial airports and higher loyalty to HAS concession partners in and away from terminal facilities. The platform also queries customers about their experience after patronizing airport concessions to provide direct feedback to vendors about service growth opportunities.

Under this partnership, the Contractor shall respond to HAS multiple strategic priorities by building platforms for future success by increasing non-aeronautical revenue and contributing to HAS's fiscal responsibility and viability over the course of the contract, make our passengers happy by providing a loyalty rewards program that is of value by partnering with vendors that matters to our customers, and invest in partnerships and employees by using the platform to increase brand awareness of airport vendors and having a positive impact on their net revenues.

This recommendation is made pursuant to Chapter 252, Section 252.022 (a) (7) (A) "a procurement of items that are available from only one source, including items that are available from only one source because of patents, copyrights, secret processes, or natural monopolies" of the Texas Local Government Code for exempted procurements.

MWBE Participation

MWBE participation zero-percentage goal document approved by the Office of Business Opportunity.

Pay or Play

The proposed contract requires compliance with the City’s ‘Pay or ‘Play ordinance regarding health benefits for employees of City contractors. In this case, Thanks Again, LLC d/b/a GlidePathCX has elected to pay in the Contractor Responsibility Fund in compliance with City policy.

Hire Houston First

This procurement is exempt from the City’s Hire Houston First Ordinance. Bids/proposals were not solicited because the department is utilizing a sole source for this purchase.

Fiscal Note

Funding for this item is included in the FY2025 Adopted Budget. Therefore, no Fiscal Note is required as stated in the Financial Policies.

Jedediah Greenfield
Chief Procurement Officer
Finance/Strategic Procurement Division

Department Approval Authority Signature

Estimated Spending Authority			
Department	FY2025	Out Years	Total
Houston Airport System (HAS)	\$400,000.00	\$800,000.00	\$1,200,000.00

Amount and Source of Funding:

\$1,200,000.00

HAS Revenue Fund

Fund No. 8001

Contact Information:

Name:	Dept./Division	Phone Number
Barbara Fisher, Division Manager	Finance/SPD	832.393.8722
Carolyn Hanahan, Assistant Chief Policy Officer	Finance/SPD	832.393.9127
Jedediah Greenfield, Chief Procurement Officer	Finance/SPD	832.393.9126

ATTACHMENTS:

Description

Coversheet

Type

Signed Cover sheet



CITY OF HOUSTON - CITY COUNCIL

Meeting Date:

Item Creation Date:

WS1188918296 - Airport Concessions Loyalty Rewards Program (Thanks Again, LLC, DBA GlidePathCX) - ORDINANCE

Agenda Item#:

Background:

Sole Source (S19-WS1188918296) – Approve an ordinance awarding a sole source agreement with Thanks Again, LLC d/b/a GlidePathCX for the maximum contract amount of \$1,200,000.00 for the airport concessions loyalty rewards program for a two-year (2) term with one (1) one-year option for the Houston Airport System (HAS).

Specific Explanation

The Director of the Houston Airport System and the Chief Procurement Officer recommend that City Council approve an ordinance awarding a sole source contract for a **two-year (2) term with one (1) one-year option to Thanks Again, LLC d/b/a GlidePathCX** in an amount not to exceed **\$1,200,000.00** for Airport Concessions Loyalty Rewards Program for the Houston Airport System.

The Houston Airport System endeavors to increase passengers’ awareness and patronage of available concessions options for parking, shopping, and dining at both Bush Intercontinental and William P. Hobby Airports. GlidePathCX by Thank Again, LLC is a proprietary program that allows airports to develop loyalty rewards for customer purchases while on airport property (parking and in-terminal sales) and in day-to-day consumer spending with airport vendors and other participating businesses. The result is an increase in non-aeronautical revenue for both commercial airports and higher loyalty to HAS concession partners in and away from terminal facilities. The platform also queries customers about their experience after patronizing airport concessions to provide direct feedback to vendors about service growth opportunities.

Under this partnership, the Contractor shall respond to HAS multiple strategic priorities by building platforms for future success by increasing non-aeronautical revenue and contributing to HAS’s fiscal responsibility and viability over the course of the contract, make our passengers happy by providing a loyalty rewards program that is of value by partnering with vendors that matters to our customers, and invest in partnerships and employees by using the platform to increase brand awareness of airport vendors and having a positive impact on their net revenues.

This recommendation is made pursuant to Chapter 252, Section 252.022 (a) (7) (A) “a procurement of items that are available from only one source, including items that are available from only one source because of patents, copyrights, secret processes, or natural monopolies” of the Texas Local Government Code for exempted procurements.

MWBE Participation

MWBE participation zero-percentage goal document approved by the Office of Business Opportunity.

Pay or Play

The proposed contract requires compliance with the City’s ‘Pay or ‘Play ordinance regarding health benefits for employees of City contractors. In this case, Thanks Again, LLC d/b/a GlidePathCX has elected to pay in the Contractor Responsibility Fund in compliance with City policy.

Hire Houston First

This procurement is exempt from the City’s Hire Houston First Ordinance. Bids/proposals were not solicited because the department is utilizing a sole source for this purchase.

Fiscal Note

Funding for this item is included in the FY2025 Adopted Budget. Therefore, no Fiscal Note is required as stated in the Financial Policies.

8/21/2024

DocuSigned by:

6121834A077C41A...

Jedediah Greenfield
Chief Procurement Officer
Finance/Strategic Procurement Division

Department Approval Authority Signature

Estimated Spending Authority			
Department	FY2025	Out Years	Total
Houston Airport Svsstem	\$400,000.00	\$800,000.00	\$1,200,000.00

(HAS)

Amount and Source of Funding:

\$1,200,000.00

HAS Revenue Fund

Fund No. 8001

Contact Information:

Name:	Dept./Division	Phone Number
Barbara Fisher, Division Manager	Finance/SPD	832.393.8722
Carolyn Hanahan, Assistant Chief Policy Officer	Finance/SPD	832.393.9127
Jedediah Greenfield, Chief Procurement Officer	Finance/SPD	832.393.9126

ATTACHMENTS:

Description

Ownership Information Form
Conflict of Interest Questionnaire
Form 1295
MWBE Waiver
POP 1
POP 2
POP 3
Drug Policy Forms
COI and Endorsements
Contract
Funding

Type

Backup Material
Backup Material
Backup Material
Backup Material
Backup Material
Backup Material
Backup Material
Backup Material
Backup Material
Contract/Exhibit
Financial Information



CITY OF HOUSTON - CITY COUNCIL

Meeting Date: 9/24/2024

ALL

Item Creation Date: 8/23/2024

WS1236492287 - Administration and Management of the
Nurse-Family Partnership Program (Nurse-Family
Partnership) - ORDINANCE

Agenda Item#: 28.

Summary:

ORDINANCE approving and authorizing contract between City of Houston and **NURSE-FAMILY PARTNERSHIP** for Administration and Management of Nurse Family Partnership Program for the Houston Health Department; providing a maximum contract amount - 1 Year with 4 one-year options - \$425,000.00 - Grant Fund

Background:

Sole Source (P43 – WS1236492287) – Approve an ordinance authorizing a contract to the Nurse-Family Partnership in an amount not to exceed \$425,000.00 for the administration and management of the Nurse-Family Partnership Program for one (1) year with four (4) one-year renewal options for the Houston Health Department.

Specific Explanation:

The Director of the Houston Health Department and the Chief Procurement Officer recommend that the City Council approve an ordinance authorizing a contract in an amount not to exceed **\$425,000.00** to the **Nurse-Family Partnership** for the administration and management of the Nurse-Family Partnership Program for one (1) year with four (4) one-year renewal options for a maximum five-year contract term.

The Houston Health Department (HHD) is partnered with Nurse-Family Partnership (NFP), an evidence-based program developed through randomized controlled trial research. The program offers registered nurse home visits to low-income, unmarried, and teenage pregnant women with no previous live births. Nurses visit the women once to twice monthly during their pregnancy and the first two years of their children's lives. The program teaches positive health-related behaviors, competent care of children, and maternal personal development, including family planning, educational achievement, and economic self-sufficiency.

The Department of Family and Protective Services (DFPS) leverages funds from the Texas Nurse-Family Partnership (TNFP) competitive grant program to award grants to community-based organizations for the implementation and operation of the NFP program. Funding from this grant is cost reimbursement for meeting program objectives and will allow HHD to provide community support through the program's benefits.

This recommendation is made pursuant to subsection 252.022(a)(4) of the Texas Local Government Code, which provides that "a procurement for personal, professional, or planning services" is exempt from the competitive requirements for purchases.

M/WBE Participation:

M/WBE zero-percentage goal approved by the Office of Business Opportunity.

Hire Houston First:

This Procurement is exempt from the City's Hire Houston First Ordinance. Bids/Proposals were not solicited because the City is utilizing a sole source vendor for this purchase.

Fiscal Note:

No Fiscal Note is required for grant-funded items.

Jedediah Greenfield, Chief Procurement Officer
Authority
Finance/ Strategic Procurement Division

Department Approval

Estimated Spending Authority			
Departments	FY2025	Out-Years	Total
Houston Health Department	\$170,000.00	\$255,000.00	\$425,000.00

Amount and Source of Funding:

\$425,000.00
 Federal/Local/State/Pass Grant Fund
 Fund 5030

Contact Information:

Name	Dept./Division	Phone No.:
Sheila Baker, Division Manager	Finance/SPD	(832) 393-8109
Carolyn Hanahan, Assistant Chief Policy Officer	Finance /SPD	(832) 393-9127
Jedediah Greenfield, Chief Procurement Officer	Finance/SPD	(832) 393-9126

ATTACHMENTS:

Description	Type
Coversheet	Signed Cover sheet



CITY OF HOUSTON - CITY COUNCIL

Meeting Date:

ALL

Item Creation Date: 8/23/2024

WS1236492287 - Administration and m-Management of the Nurse-Family Partnership Program (Nurse-Family Partnership) - ORDINANCE

Agenda Item#:

Summary:

NOT A REAL CAPTION

ORDINANCE approving and authorizing contract between the City and **NURSE-FAMILY PARTNERSHIP** for Administration and Management of a Nurse Family Partnership Program; providing a maximum contract amount - 1 year with four additional one-year terms - \$425,000.00 - Grant Fund

Background:

Sole Source (P43 – WS1236492287) – Approve an ordinance authorizing a contract to the Nurse-Family Partnership in an amount not to exceed \$425,000.00 for the administration and management of the Nurse-Family Partnership Program for one (1) year with four (4) one-year renewal options for the Houston Health Department.

Specific Explanation:

The Director of the Houston Health Department and the Chief Procurement Officer recommend that the City Council approve an ordinance authorizing a contract in an amount not to exceed **\$425,000.00** to the **Nurse-Family Partnership** for the administration and management of the Nurse-Family Partnership Program for one (1) year with four (4) one-year renewal options for a maximum five-year contract term.

The Houston Health Department (HHD) is partnered with Nurse-Family Partnership (NFP), an evidence-based program developed through randomized controlled trial research. The program offers registered nurse home visits to low-income, unmarried, and teenage pregnant women with no previous live births. Nurses visit the women once to twice monthly during their pregnancy and the first two years of their children's lives. The program teaches positive health-related behaviors, competent care of children, and maternal personal development, including family planning, educational achievement, and economic self-sufficiency.

The Department of Family and Protective Services (DFPS) leverages funds from the Texas Nurse-Family Partnership (TNFP) competitive grant program to award grants to community-based organizations for the implementation and operation of the NFP program. Funding from this grant is cost reimbursement for meeting program objectives and will allow HHD to provide community support through the program's benefits.

This recommendation is made pursuant to subsection 252.022(a)(4) of the Texas Local Government Code, which provides that "a procurement for personal, professional, or planning services" is exempt from the competitive requirements for purchases.

M/WBE Participation:

M/WBE zero-percentage goal approved by the Office of Business Opportunity.

Hire Houston First:

This Procurement is exempt from the City's Hire Houston First Ordinance. Bids/Proposals were not solicited because the City is utilizing a sole source vendor for this purchase.

Fiscal Note:

No Fiscal Note is required for grant-funded items.

8/30/2024

6121834A077C41A...

Jedediah Greenfield, Chief Procurement Officer
Finance/ Strategic Procurement Division

DocuSigned by:

A8219D332CF4498...

Department Approval Authority

8/30/2024

Estimated Spending Authority			
Departments	FY2025	Out-Years	Total
Houston Health Department	\$170,000.00	\$255,000.00	\$425,000.00

Amount and Source of Funding:

\$425,000.00

Federal/Local/State/Pass Grant Fund

Fund 5030

Contact Information:

Name	Dept./Division	Phone No.:
Sheila Baker, Division Manager	Finance/SPD	(832) 393-8109
Carolyn Hanahan, Assistant Chief Policy Officer	Finance /SPD	(832) 393-9127
Jedediah Greenfield, Chief Procurement Officer	Finance/SPD	(832) 393-9126

ATTACHMENTS:

Description	Type
COF	Financial Information
Form A	Financial Information
Delinquent Tax Report	Backup Material
Ownership Information Form	Backup Material
Form 1295	Backup Material
Form CIQ	Backup Material
Justification Form	Backup Material
MWBE Goal	Backup Material
SAMS	Backup Material



CITY OF HOUSTON - CITY COUNCIL

Meeting Date: 9/24/2024

ALL

Item Creation Date: 9/10/2024

MYR - TIRZ Appropriation Harris County, Ft. Bend County,
Community College, ISD \$17,245,906.03

Agenda Item#: 29.

Summary:

ORDINANCE appropriating \$17,245,906.03 out of City of Houston, Texas, Tax Increment Funds for **REINVESTMENT ZONES TWO (MIDTOWN ZONE), THREE (MAIN STREET/MARKET SQUARE ZONE), ELEVEN (GREATER GREENSPOINT ZONE), FIFTEEN (EAST DOWNTOWN ZONE), and TWENTY-FIVE (HIRAM CLARKE FORT BEND ZONE)**, for payment to **HARRIS COUNTY, TEXAS**, for Affordable Housing, Payment of Administrative Expenses, and Payments to certain Redevelopment Authorities as provided herein

Background:

The appropriation of \$17,245,906.03 results from tax increment payments received in the City's tax year 2023 from the Houston Community College, Harris County, Harris County Flood Control, Lone Star College, Aldine Independent School District, and Fort Bend County for transfer to the various TIRZs.

As shown in the attached spreadsheet, \$281,400.15 will be transferred to the Harris County Community Services Department and \$84,487.20 will be transferred to the General Fund for TIRZ administrative costs. The remaining appropriation, \$16,880,018.68, will be paid to the various redevelopment authorities on behalf of the TIRZ.

All tri-party agreements and creation documents can be found on the following website:
<http://www.houstontx.gov/ecodev/>

Gwendolyn Tillotson - Bell, Chief Economic Development Officer

Prior Council Action:

Ordinance No. 2023-660, 8/23/23

Contact Information:

__ Jennifer D. Curley, Assistant Director
Phone: (832) 393 - 0981

ATTACHMENTS:

Description

Coversheet

Backup (2)

Type

Signed Cover sheet

Backup Material



CITY OF HOUSTON - CITY COUNCIL

Meeting Date: 9/24/2024

ALL

Item Creation Date: 9/10/2024

MYR - TIRZ Appropriation Harris County, Ft. Bend County, Community College, ISD
\$17,245,906.03

Agenda Item#: 49.

Background:

The appropriation of \$17,245,906.03 results from tax increment payments received in the City's tax year 2023 from the Houston Community College, Harris County, Harris County Flood Control, Lone Star College, Aldine Independent School District, and Fort Bend County for transfer to the various TIRZs.

As shown in the attached spreadsheet, \$281,400.15 will be transferred to the Harris County Community Services Department and \$84,487.20 will be transferred to the General Fund for TIRZ administrative costs. The remaining appropriation, \$16,880,018.68, will be paid to the various redevelopment authorities on behalf of the TIRZ.

All tri-party agreements and creation documents can be found on the following website:
<http://www.houstontx.gov/ecodev/>

DocuSigned by:

Gwendolyn Tillotson - Bell, Chief Economic Development Officer

Prior Council Action:

Ordinance No. 2023-660, 8/23/23

Contact Information:

Jennifer D. Curley, Assistant Director
Phone: (832) 393 - 0981

ATTACHMENTS:

Description

PCA 2023-660

Type

Backup Material

#	TIRZ	Jurisdiction New/Old	Fund #	Increment Payments	Harris County Affordable Housing	Administrative Transfer to General Fund	Net Increment due to Redevelopment Authority	Payee	SAP Budget
2	Midtown		7550	\$ 2,012,109.62		\$ 25,000.00	\$ 1,987,109.62	Midtown RA	101004979
	Houston	300		\$ 1,186,596.37		\$ 8,333.33	\$ 1,178,263.04		
	Community	302		\$ 529,395.77		\$ 8,333.33	\$ 521,062.44		
	College	304		\$ 296,117.48		\$ 8,333.34	\$ 287,784.14		
3	Main Street		7551	\$ 189,744.00		\$ 9,487.20	\$ 180,256.80	Market Square RA	101004980
	Harris County	280/267		\$ 174,304.00		\$ 8,715.20	\$ 165,588.80		
	Harris County Flood Control	259		\$ 15,440.00		\$ 772.00	\$ 14,668.00		
11	Greenspoint			\$ 12,710,877.66		\$ 50,000.00	\$ 12,660,877.66	Greenspoint RA	101004981
	Lone Star College		7559	\$ 1,591,497.00		\$ 25,000.00	\$ 1,566,497.00		
	Aldine ISD			\$ 11,119,380.66		\$ 25,000.00	\$ 11,094,380.66		
15	East Downtown		7563	\$ 1,876,001.00	\$ 281,400.15	\$ - (1)	\$ 1,594,600.85	Special Pay	101004982
	Harris County	923/596		\$ 469,435.00	\$ 70,415.25	\$ - (2)	\$ 399,019.75		
		929/938		\$ 1,406,566.00	\$ 210,984.90	\$ -	\$ 1,195,581.10		
25	Hiram Clarke		7582	457,173.75		-	457,173.75	Hiram Clarke RA	101004984
	Ft. Bend County			457,173.75		-	457,173.75		
	Total			\$ 17,245,906.03	\$ 281,400.15	\$ 84,487.20	\$ 16,880,018.68		

Notes:

- 1) County does not contribute to the Administrative Fee per the Interlocal Agreement.
- 2) Amount of affordable housing set-aside to be transferred to Harris County's Homeless Housing Program (15%)

Special Pay Instructions:

Transfer Harris County Affordable Housing to Harris County Community Services Department	\$ 281,400.15
Transfer net increment to East Downtown Redevelopment Authority	\$ 1,594,600.85
Total East Downtown Increment	\$ 1,876,001.00



CITY OF HOUSTON - CITY COUNCIL

Meeting Date: 9/24/2024

ALL

Item Creation Date: 9/10/2024

MYR - TIRZ Appropriation 2025 HISD Pass Through
\$27,102,306

Agenda Item#: 30.

Summary:

ORDINANCE appropriating \$27,102,306.00 out of City of Houston, Texas Tax Increment Funds for **REINVESTMENT ZONE NUMBERS ONE (SAINT GEORGE PLACE ZONE), TWO (MIDTOWN ZONE), THREE (MAIN STREET/MARKET SQUARE ZONE), SIX (EASTSIDE ZONE), SEVEN (OLD SPANISH TRAIL/ALMEDA CORRIDORS ZONE), EIGHT (GULFGATE ZONE), TWELVE (CITY PARK ZONE), THIRTEEN (OLD SIXTH WARD ZONE), FOURTEEN (FOURTH WARD ZONE), FIFTEEN (EAST DOWNTOWN ZONE), SIXTEEN (UPTOWN ZONE), AND EIGHTEEN (FIFTH WARD ZONE)**, City of Houston, Texas, for payment of affordable housing costs, payments to **HOUSTON INDEPENDENT SCHOOL DISTRICT**, and payments to certain redevelopment authorities as provided herein

Background:

The appropriation of \$27,102,306 results from tax increment payments received in the City's Fiscal Year 2025 from HISD for transfer to the various TIRZs.

As shown in the attached spreadsheet, \$2,468,359 will be transferred to the City's Affordable Housing Fund; \$20,727,916.61 will be paid to HISD for Educational Facilities Project Costs, \$3,906,030.39 will be paid to the Midtown Redevelopment Authority for their affordable housing program.

All tri-party agreements and creation documents can be found on the following website:
<http://www.houstontx.gov/ecodev/>

Gwendolyn Tillotson-Bell, Chief Economic Development Officer

Prior Council Action:

Ordinance No. 2023-702, 8/30/23

Contact Information:

____ Jennifer D. Curley, Assistant Director
Phone: (832) 393-0981

ATTACHMENTS:

Description

Coversheet

Backup

Type

Signed Cover sheet

Backup Material



CITY OF HOUSTON - CITY COUNCIL

Meeting Date: 9/24/2024

ALL

Item Creation Date: 9/10/2024

MYR - TIRZ Appropriation 2025 HISD Pass Through \$27,102,306

Agenda Item#: 50.

Background:

The appropriation of \$27,102,306 results from tax increment payments received in the City's Fiscal Year 2025 from HISD for transfer to the various TIRZs.

As shown in the attached spreadsheet, \$2,468,359 will be transferred to the City's Affordable Housing Fund; \$20,727,916.61 will be paid to HISD for Educational Facilities Project Costs, \$3,906,030.39 will be paid to the Midtown Redevelopment Authority for their affordable housing program.

All tri-party agreements and creation documents can be found on the following website:

<http://www.houstontx.gov/ecodev/>

DocuSigned by:

A handwritten signature in blue ink that reads "Gwendolyn Tillotson-Bell".

Gwendolyn Tillotson-Bell, Chief Economic Development Officer

Prior Council Action:

Ordinance No. 2023-702, 8/30/23

DS

Contact Information:

Jennifer D. Curley, Assistant Director

Phone: (832) 393-0981

ATTACHMENTS:

Description	Type
PCA 2023-702	Backup Material

**Fiscal Year 2025 Houston ISD
Pass Through Increment**

Zone	TIRZ	Fund	Houston ISD Pass Through Funds	City Affordable Housing	Zone/RDA Affordable Housing	Payment Amount to Houston ISD for Educational Facilities	SAP Document
1	St Georges Place	7512	991,447.00	330,482.00	-	660,965.00	
2	Midtown	7550	9,554,419.00	-	3,906,030.39	5,648,388.61	
3	Main Street	7551	3,509,884.00	-	-	3,509,884.00	
6	Eastside	7554	4,228,460.00	-	-	4,228,460.00	
7	Old Spanish Trail	7555	1,040,471.00	-	-	1,040,471.00	
8	Gulfgate	7556	595,077.00	-	-	595,077.00	
12	City Park	7560	263,923.00	-	-	263,923.00	
13	Old Sixth Ward	7561	284,407.00	94,802.00		189,605.00	
14	Fourth Ward	7562	662,578.00	220,859.00	-	441,719.00	
15	East Downton	7563	410,339.00			410,339.00	
16	Uptown	7564	5,466,649.00	1,822,216.00	-	3,644,433.00	
18	Fifth Ward	7566	94,652.00			94,652.00	
			27,102,306.00	2,468,359.00	3,906,030.39	20,727,916.61	

The following sets forth several requested appropriations: a) FY2025 Houston ISD pass through b) Transfer of affordable housing proceeds to Fund 2409 and Midtown Redevelopment Authority.



CITY OF HOUSTON - CITY COUNCIL

Meeting Date: 9/24/2024

District D

Item Creation Date:

PLN - Protected Landmark Designation: Braswell Building at
5613 Almeda Road

Agenda Item#: 31.

Summary:

ORDINANCE designating the property municipally known as **5613 Almeda Road, Houston, TX 77004** and also known as “Braswell Building” being located within the City of Houston, Texas, as a Protected Landmark; containing findings and other provisions related to the foregoing subject; providing for a penalty - **DISTRICT D - EVANS-SHABAZZ**

Background:

Chapter 33, Section 33-222 of the Code of Ordinances allows for City Council to designate a Landmark or Protected Landmark upon application by property owner.

This application for **Protected Landmark** designation of Braswell Building at 5613 Almeda Road was initiated by the owners. Property ownership documents were submitted and verified by the Legal Department.

A public hearing was held on December 14, 2023 by the Houston Archaeological and Historical Commission. Two persons attended the hearing and expressed opposition to the designation. The Houston Archaeological and Historical Commission had no objections and determined that the application satisfied applicable criteria of the ordinance and unanimously recommended approval of the Protected Landmark designation.

City Council held a public hearing on the designation request on Wednesday, June 26, 2024, 9:00 a.m., in the City Hall Council Chambers. Notice of the public hearing date was published in a local newspaper of general circulation. Four persons attended the hearing. Three spoke in support of the designation; and one person spoke in opposition, and also read comments from an additional opponent to the designation.

The Planning and Development Department recommends that City Council approve the designation of 5613 Almeda Road as a Protected Landmark.

Jennifer Ostlind, AICP
Interim Director

Planning and Development Department

Contact Information:

Anna Sedillo, Council Liaison
832-393-6578

Cara Quigley, Planner I
832-393-6562

ATTACHMENTS:

Description

RCA

Type

Signed Cover sheet



CITY OF HOUSTON - CITY COUNCIL

Meeting Date: 7/23/2024

District D

Item Creation Date:

PLN - Protected Landmark Designation: Braswell Building at 5613 Almeda Road

Agenda Item#: 32.

Summary:

NOT A REAL CAPTION

ORDINANCE designating the property municipally known as 5613 Almeda Road and also known as the "*Braswell Building*" being located within the City of Houston, Texas, as a protected landmark; containing findings and other provisions related to the foregoing subject; providing for a penalty - **DISTRICT D - EVANS-SHABAZZ**

Background:

Chapter 33, Section 33-222 of the Code of Ordinances allows for City Council to designate a Landmark or Protected Landmark upon application by property owner.

This application for **Protected Landmark** designation of Braswell Building at 5613 Almeda Road was initiated by the owners. Property ownership documents were submitted and verified by the Legal Department.

A public hearing was held on December 14, 2023 by the Houston Archaeological and Historical Commission. Two persons attended the hearing and expressed opposition to the designation. The Houston Archaeological and Historical Commission had no objections and determined that the application satisfied applicable criteria of the ordinance and unanimously recommended approval of the Protected Landmark designation.

City Council held a public hearing on the designation request on Wednesday, June 26, 2024, 9:00 a.m., in the City Hall Council Chambers. Notice of the public hearing date was published in a local newspaper of general circulation. Four persons attended the hearing. Three spoke in support of the designation; and one person spoke in opposition, and also read comments from an additional opponent to the designation.

The Planning and Development Department recommends that City Council approve the designation of 5613 Almeda Road as a Protected Landmark.

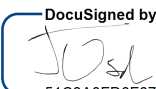
DocuSigned by:

5163A0FD6F6743D
Jennifer Ostlind, AICP
Interim Director
Planning and Development Department

Contact Information:

Anna Sedillo, Council Liaison
832-393-6578

Cara Quigley, Planner I
832-393-6562

ATTACHMENTS:

Description	Type
Designation Report	Backup Material
Legal Notice	Backup Material



CITY OF HOUSTON - CITY COUNCIL

Meeting Date: 9/24/2024

ETJ

Item Creation Date: 8/20/2024

HPW - 20WR514 – Petition Addition (34.1226) Porter
Municipal Utility District

Agenda Item#: 32.

Summary:

ORDINANCE consenting to the addition of 34.1226 acres of land to **PORTER MUNICIPAL UTILITY DISTRICT**, for inclusion in its district

Background:

SUBJECT: Petition for the City's consent to the addition of 34.1226 acres to Porter Municipal Utility District.

RECOMMENDATION: Petition for the City's consent to the addition of 34.1226 acres to Porter Municipal Utility District be approved.

SPECIFIC EXPLANATION: Porter Municipal Utility District (the "District") was created through the TCEQ in 1978, and currently consists of 4,035.0174 acres within Montgomery County. The District is within the extraterritorial jurisdiction of the City of Houston (the "City") and has petitioned the City for consent to add 34.1226 acres of vacant land, proposed to be developed as multi-family residential and commercial property, to the District. The proposed annexation tract is located in the vicinity of Auburn Fields Drive, FM 1314, and US Highway 59. The addition of land to the District does not release it from the City's extraterritorial jurisdiction.

The Utility District Review Committee has evaluated the application with respect to wastewater collection and treatment, potable water distribution, storm water conveyance, and other public services.

The District has a wastewater collection system and treatment facility. The annexation tract will be provided with wastewater treatment by the Porter Municipal Utility District Wastewater Treatment Facility. This regional plant also provides wastewater treatment to Porter Special Utility District and Woodridge Municipal Utility District. Potable water is provided by the Porter Special Utility District.

The nearest major drainage facility for Porter Municipal Utility District is Ben's Branch, which flows into San Jacinto River, and finally into the Houston Ship Channel. Ben's Branch is within the San Jacinto River watershed. The proposed annexation tract is not within the 100- or 500-year floodplain.

By executing the Petition for Consent, the District has acknowledged that all plans for the

construction of water conveyance, wastewater collection, and storm water collection systems within the District must be approved by the City prior to their construction.

The Utility District Review Committee recommends that the subject petition be approved.

Randall V. Macchi
Chief Operating Officer
Houston Public Works

Contact Information:

Name	Service Line	Contact No.
Roberto Medina, Interim Chief of Staff	DO-HPW Government Relations	832.395.2456
Maria Perez, HPW Agenda Coordinator	DO-HPW Government Relations	832.395.2282
Ekaterina Fitos, HPW Planning Director	HPW Houston Water	832.395.2712

ATTACHMENTS:

Description

Signed Coversheet
Maps

Type

Signed Cover sheet
Backup Material



CITY OF HOUSTON - CITY COUNCIL

Meeting Date:

ETJ

Item Creation Date: 8/20/2024

HPW - 20WR514 – Petition Addition (34.1226) Porter Municipal Utility District

Agenda Item#:

Background:

SUBJECT: Petition for the City’s consent to the addition of 34.1226 acres to Porter Municipal Utility District.

RECOMMENDATION: Petition for the City’s consent to the addition of 34.1226 acres to Porter Municipal Utility District be approved.

SPECIFIC EXPLANATION: Porter Municipal Utility District (the “District”) was created through the TCEQ in 1978, and currently consists of 4,035.0174 acres within Montgomery County. The District is within the extraterritorial jurisdiction of the City of Houston (the “City”) and has petitioned the City for consent to add 34.1226 acres of vacant land, proposed to be developed as multi-family residential and commercial property, to the District. The proposed annexation tract is located in the vicinity of Auburn Fields Drive, FM 1314, and US Highway 59. The addition of land to the District does not release it from the City’s extraterritorial jurisdiction.

The Utility District Review Committee has evaluated the application with respect to wastewater collection and treatment, potable water distribution, storm water conveyance, and other public services.

The District has a wastewater collection system and treatment facility. The annexation tract will be provided with wastewater treatment by the Porter Municipal Utility District Wastewater Treatment Facility. This regional plant also provides wastewater treatment to Porter Special Utility District and Woodridge Municipal Utility District. Potable water is provided by the Porter Special Utility District.

The nearest major drainage facility for Porter Municipal Utility District is Ben’s Branch, which flows into San Jacinto River, and finally into the Houston Ship Channel. Ben’s Branch is within the San Jacinto River watershed. The proposed annexation tract is not within the 100- or 500-year floodplain.

By executing the Petition for Consent, the District has acknowledged that all plans for the construction of water conveyance, wastewater collection, and storm water collection systems within the District must be approved by the City prior to their construction.

The Utility District Review Committee recommends that the subject petition be approved.

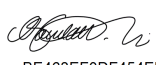
DocuSigned by:

 9/9/2024
 BE463EF0DF454EB...

Randall V. Macchi
 Chief Operating Officer
 Houston Public Works

Contact Information:

Name	Service Line	Contact No.
Roberto Medina, Interim Chief of Staff	DO-HPW Government Relations	832.395.2456
Maria Perez, HPW Agenda Coordinator	DO-HPW Government Relations	832.395.2282
Ekaterina Fitos, HPW Planning Director	HPW Houston Water	832.395.2712

ATTACHMENTS:

Description	Type
Maps	Backup Material
Application	Backup Material
Petition	Backup Material
Fact Sheet	Backup Material

Z:\2022\U22-00034\PHASE IV ANNEX 34.122 Oakfield MF\DWG\U22-00034 Porter MUD Annexation_BNDY_TB7 VICINITY MAP.dwg

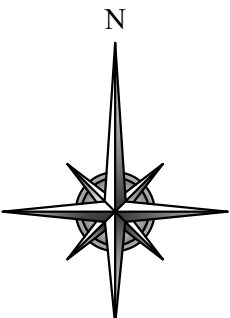
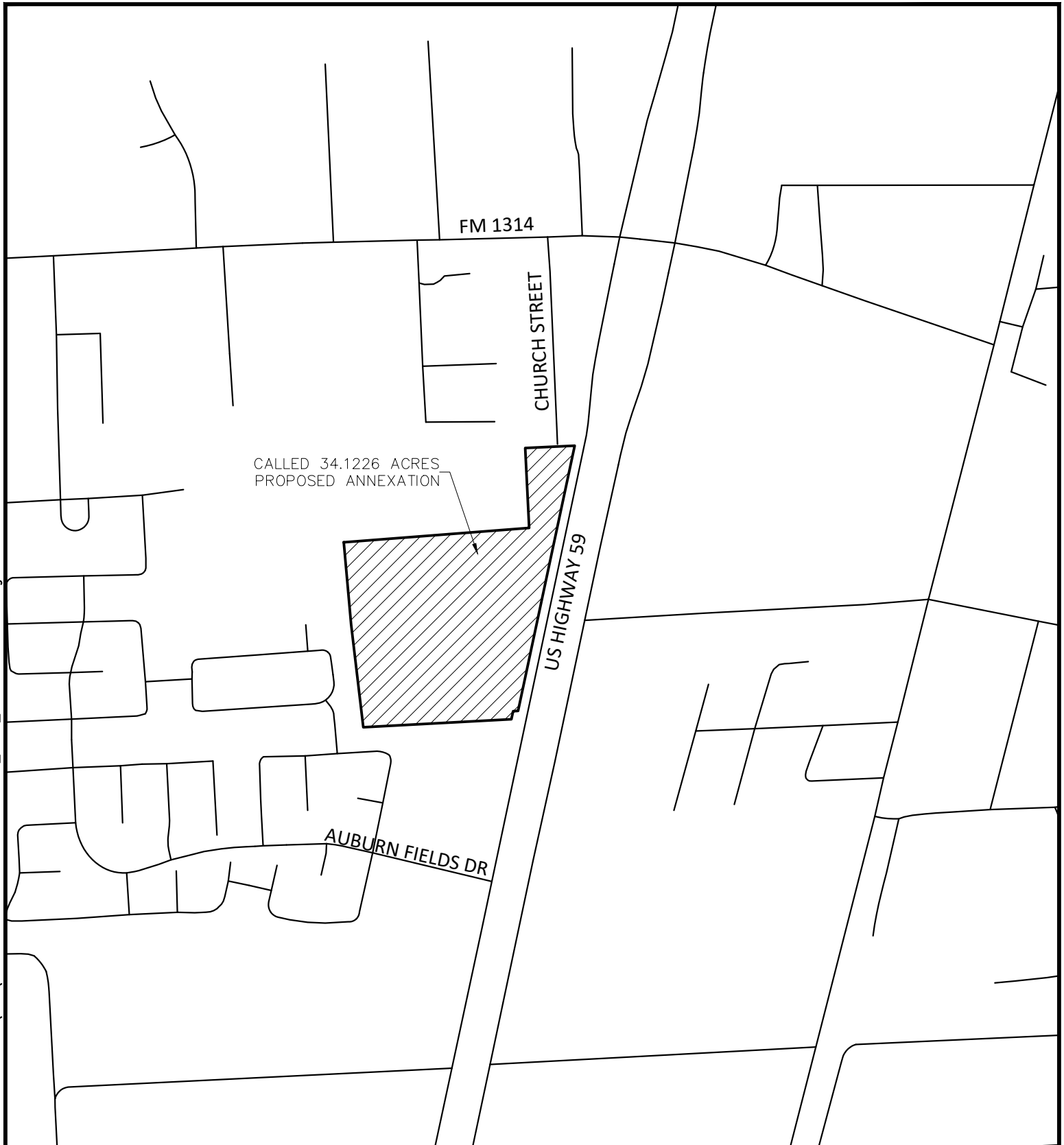

VICINITY MAP
NOT TO SCALE

PORTER MUNICIPAL
UTILITY DISTRICT
ACREAGE: 4,035.0174

 PROPOSED





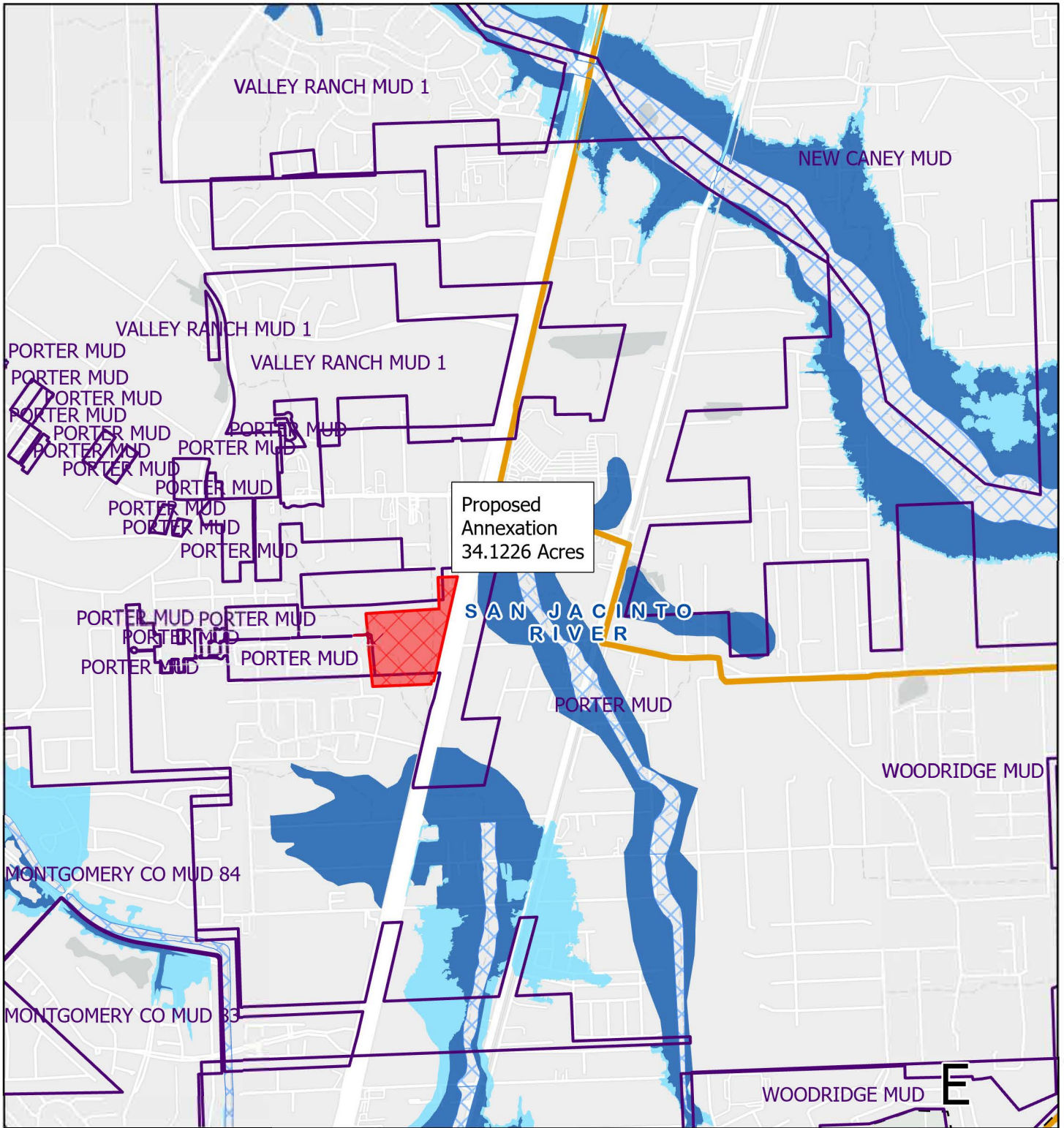



CORE
 LAND SURVEYING TBPLS REG NO. 10194560
 10210 GROGANS MILL ROAD, SUITE 120
 THE WOODLANDS, TX 77380
 T: 224.828.1208
 corelandsurveying.com

Porter Municipal Utility District (34.1226 acres)



6/6/2024 3:17 PM

1:26,842

- | | |
|--|---|
|  Watersheds |  500 Year Floodplain |
|  Texas Senate Districts |  Floodway |
|  Texas House Districts |  City Limits |
| Flood Hazard Zones |  Council Districts |
|  100 Year Floodplain |  Existing District |

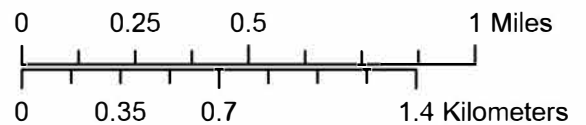



CITY OF HOUSTON - CITY COUNCIL

Meeting Date: 9/24/2024

ETJ

Item Creation Date:

HPW - 20WR525 - Petition Addition (0.717) Harris County
Municipal Utility District No. 477

Agenda Item#: 33.

Summary:

ORDINANCE consenting to the addition of 0.717 acres of land to **HARRIS COUNTY MUNICIPAL UTILITY DISTRICT NO. 477**, for inclusion in its district

Background:

SUBJECT: Petition for the City's consent to the addition of 0.717 acres to Harris County Municipal Utility District No. 477.

RECOMMENDATION: Petition for the City's consent to the addition of 0.717 acres to Harris County Municipal Utility District No. 477 be approved.

SPECIFIC EXPLANATION: Harris County Municipal Utility District No. 477 (the "District") was created through the TCEQ in 2008, and currently consists of 444.294 acres within Harris County. The District is within the extraterritorial jurisdiction of the City of Houston (the "City") and has petitioned the City for consent to add 0.717 acres of vacant land, proposed to be developed as other property which will consist of landscape and open space to the District. The proposed annexation tract is located in the vicinity of Baethe Road, US 290, Warren Ranch Road and Katy Hockley Road. The addition of land to the District does not release it from the City's extraterritorial jurisdiction.

The Utility District Review Committee has evaluated the application with respect to wastewater collection and treatment, potable water distribution, storm water conveyance, and other public services.

The District will have a wastewater collection system and treatment facility. The annexation tract will be provided with wastewater treatment by the Harris County Municipal Utility District 477 Wastewater Treatment Facility. Potable water is provided by the District.

The nearest major drainage facility for Harris County Municipal Utility District No. 477 is Cypress Creek, which flows into Spring Creek, then to the San Jacinto River, and finally into Lake Houston. The proposed annexation tract is not within the 100- or 500-year floodplain.

By executing the Petition for Consent, the District has acknowledged that all plans for the construction of water conveyance, wastewater collection, and storm water collection systems within

the District must be approved by the City prior to their construction.

The Utility District Review Committee recommends that the subject petition be approved.

Randall V. Macchi
Chief Operating Officer
Houston Public Works

Contact Information:

Point of Contact:

Name	Service Line	Contact No.
Roberto Medina, Interim Chief of Staff	DO-HPW Government Relations	832.395.2456
Maria Perez, HPW Agenda Coordinator	DO-HPW Government Relations	832.395.2282
Ekaterina Fitos, Planning Director	HPW Houston Water	832.395.2712

ATTACHMENTS:

Description

Signed Coversheet
Maps

Type

Signed Cover sheet
Backup Material



CITY OF HOUSTON - CITY COUNCIL

Meeting Date:

ETJ

Item Creation Date:

HPW - 20WR525 - Petition Addition (0.717) Harris County Municipal Utility District No. 477

Agenda Item#:

Background:

SUBJECT: Petition for the City’s consent to the addition of 0.717 acres to Harris County Municipal Utility District No. 477.

RECOMMENDATION: Petition for the City’s consent to the addition of 0.717 acres to Harris County Municipal Utility District No. 477 be approved.

SPECIFIC EXPLANATION: Harris County Municipal Utility District No. 477 (the “District”) was created through the TCEQ in 2008, and currently consists of 444.294 acres within Harris County. The District is within the extraterritorial jurisdiction of the City of Houston (the “City”) and has petitioned the City for consent to add 0.717 acres of vacant land, proposed to be developed as other property which will consist of landscape and open space to the District. The proposed annexation tract is located in the vicinity of Baethe Road, US 290, Warren Ranch Road and Katy Hockley Road. The addition of land to the District does not release it from the City’s extraterritorial jurisdiction.

The Utility District Review Committee has evaluated the application with respect to wastewater collection and treatment, potable water distribution, storm water conveyance, and other public services.

The District will have a wastewater collection system and treatment facility. The annexation tract will be provided with wastewater treatment by the Harris County Municipal Utility District 477 Wastewater Treatment Facility. Potable water is provided by the District.

The nearest major drainage facility for Harris County Municipal Utility District No. 477 is Cypress Creek, which flows into Spring Creek, then to the San Jacinto River, and finally into Lake Houston. The proposed annexation tract is not within the 100- or 500-year floodplain.

By executing the Petition for Consent, the District has acknowledged that all plans for the construction of water conveyance, wastewater collection, and storm water collection systems within the District must be approved by the City prior to their construction.

The Utility District Review Committee recommends that the subject petition be approved.

DocuSigned by:

 9/9/2024
BE463EF0DF454EB...

Randall V. Macchi
Chief Operating Officer
Houston Public Works

Contact Information:

Point of Contact:

Name	Service Line	Contact No.
Roberto Medina, Interim Chief of Staff	DO-HPW Government Relations	832.395.2456
Maria Perez, HPW Agenda Coordinator	DO-HPW Government Relations	832.395.2282
Ekaterina Fitos, Planning Director	HPW Houston Water	832.395.2712

ATTACHMENTS:

Description	Type
Maps	Backup Material
Application	Backup Material
Petition	Backup Material
Backup Material	Backup Material
Fact Sheet	Backup Material

HARRIS COUNTY MUD NO. 477

KEY MAPS: 323D, 324A, 324B, 324C, 324D, 323H, 324E, 324F, 324G, 324H, 323M, 324J, 324K, 324L, 324M, 323R, 324N, 324P, 324Q, 324R, 323V, 324S, 324T, 324U, 324V

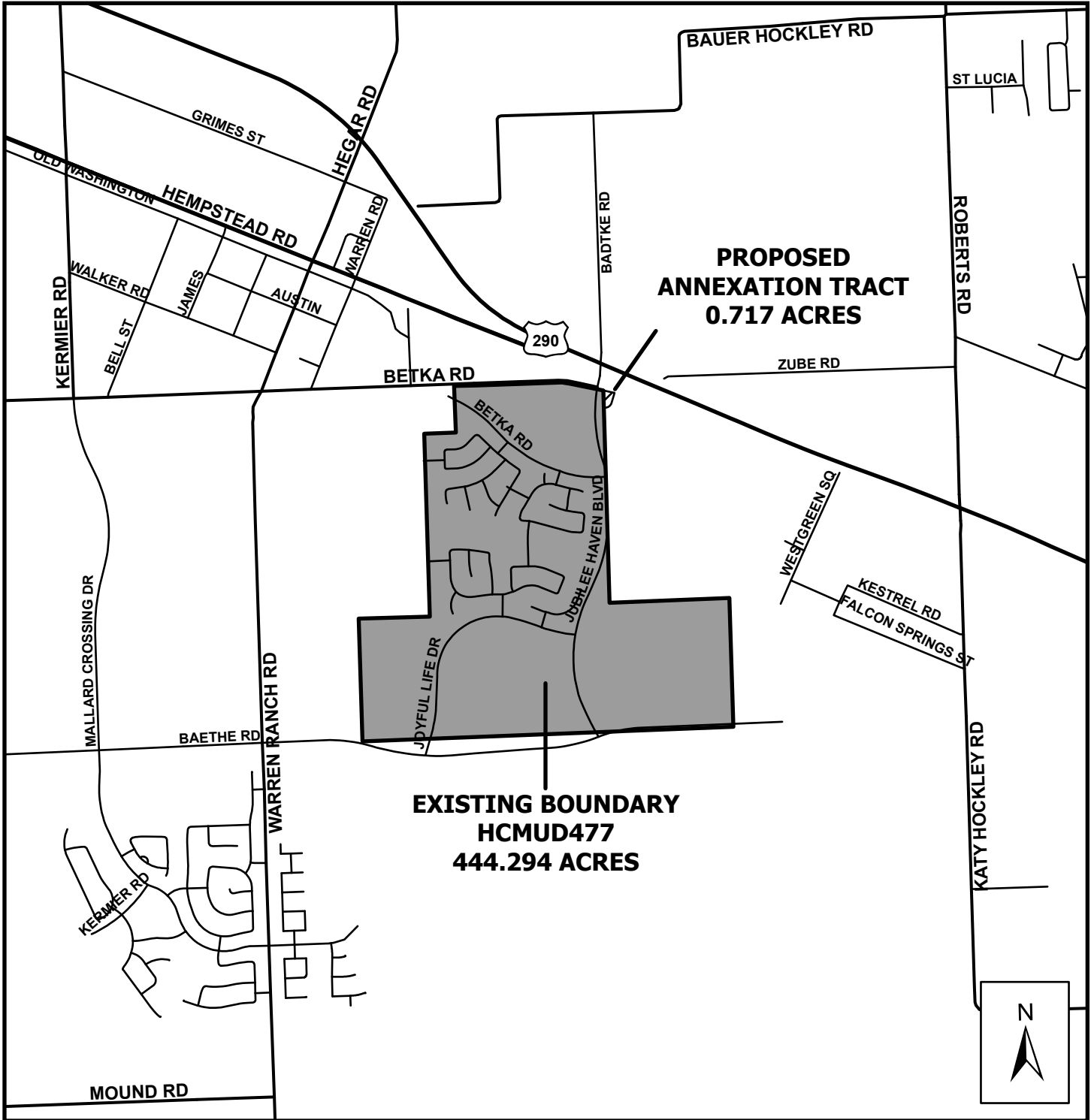

VICINITY EXHIBIT

N.T.S.

Harris County Municipal Utility District No. 477 (0.717 acres)



8/7/2024 2:03 PM

1:9,682

- Watersheds
- Texas Senate Districts
- Texas House Districts
- Flood Hazard Zones**
- 100 Year Floodplain
- 500 Year Floodplain
- Floodway
- City Limits
- Council Districts
- Existing District

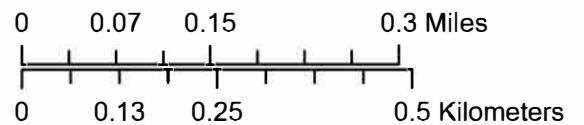



CITY OF HOUSTON - CITY COUNCIL

Meeting Date: 9/24/2024

ALL

Item Creation Date: 8/23/2024

20FMS90 - Settlement Agreement - Calcium Nitrate
(Evoqua Water Technologies, LLC) - ORDINANCE

Agenda Item#: 34.

Summary:

ORDINANCE approving and authorizing Full and Final Settlement, Indemnity Agreement and Release between City of Houston and **EVOQUA WATER TECHNOLOGIES, LLC** for Calcium Nitrate for Houston Public Works; providing a settlement amount - \$198,569.52 - Enterprise Fund

Background:

20FMS90- Adopt an Ordinance approving and authorizing a full and final settlement, confidentiality and indemnity agreement and release between the City of Houston and Evoqua Water Technologies, LLC in the total amount of \$198,569.52 for calcium nitrate for Houston Public Works.

Specific Explanation:

The Chief Operating Officer of Houston Public Works (HPW) recommends that City Council approve and authorize a full and final settlement, and confidentiality agreement and release between the City of Houston and Evoqua Water Technologies, LLC in the total amount of \$198,569.52 for the supply of calcium nitrate for Houston Public Works.

Motion No. 2019-0379 was approved by City Council on July 17, 2019, in the amount of \$2,692,800.00 for the supply of liquid calcium nitrate. Liquid Calcium Nitrate is used to control hydrogen sulfide odors caused by raw domestic wastewater conveyance through the sanitary sewer lines. Odor control is necessary to bring hydrogen sulfide levels below public nuisance levels. By Motion No. 2023-0048, dated July 18, 2023, City Council increased the spending authority by \$1,077,120.00 for a total of \$3,769,920.00. The vendor continued to provide this chemical past the contract expiration date. Upon final accounting, it was confirmed that HPW had exceeded the contract target value by \$198,569.52. The City and Evoqua Water Technologies, LLC agree that \$198,569.52 is owed to Evoqua for the chemical supplied.

Fiscal Note:

Funding for this item is included in the FY25 Adopted Budget. Therefore, no Fiscal note is required as stated in the Financial Policies.

Randall V. Macchi, Chief Operating Officer
Houston Public Works

<u>Estimated Spending Authority:</u>			
Department	FY2025	Out Years	Total
Houston Public Works	\$198,569.52	\$0	\$198,569.52

Prior Council Action:

Motion #2019-0379, dated July 17, 2019
Motion #2023-0048, dated January 18, 2023

Amount and Source of Funding:

\$198,569.52
Water & Sewer System Operating Fund
Fund: 8300

Contact Information:

Brian Blum, Assistant Director HPW/PFW (832) 395-2717

ATTACHMENTS:

Description	Type
Signed Coversheet	Signed Cover sheet



CITY OF HOUSTON - CITY COUNCIL

Meeting Date:

ALL

Item Creation Date: 8/23/2024

20FMS90 - Settlement Agreement - Calcium Nitrate (Evoqua Water Technologies, LLC) - ORDINANCE

Agenda Item#:

Background:

20FMS90- Adopt an Ordinance approving and authorizing a full and final settlement, confidentiality and indemnity agreement and release between the City of Houston and Evoqua Water Technologies, LLC in the total amount of \$198,569.52 for calcium nitrate for Houston Public Works.

Specific Explanation:

The Chief Operating Officer of Houston Public Works (HPW) recommends that City Council approve and authorize a full and final settlement, and confidentiality agreement and release between the City of Houston and Evoqua Water Technologies, LLC in the total amount of \$198,569.52 for the supply of calcium nitrate for Houston Public Works.

Motion No. 2019-0379 was approved by City Council on July 17, 2019, in the amount of \$2,692,800.00 for the supply of liquid calcium nitrate. Liquid Calcium Nitrate is used to control hydrogen sulfide odors caused by raw domestic wastewater conveyance through the sanitary sewer lines. Odor control is necessary to bring hydrogen sulfide levels below public nuisance levels. By Motion No. 2023-0048, dated July 18, 2023, City Council increased the spending authority by \$1,077,120.00 for a total of \$3,769,920.00. The vendor continued to provide this chemical past the contract expiration date. Upon final accounting, it was confirmed that HPW had exceeded the contract target value by \$198,569.52. The City and Evoqua Water Technologies, LLC agree that \$198,569.52 is owed to Evoqua for the chemical supplied.

Fiscal Note:

Funding for this item is included in the FY25 Adopted Budget. Therefore, no Fiscal note is required as stated in the Financial Policies.

DocuSigned by:

Randall E. Macchi, Chief Operating Officer
Houston Public Works

Estimated Spending Authority:

Department	FY2025	Out Years	Total
Houston Public Works	\$198,569.52	\$0	\$198,569.52

Prior Council Action:

Motion #2019-0379, dated July 17, 2019
Motion #2023-0048, dated January 18, 2023

Amount and Source of Funding:

\$198,569.52
Water & Sewer System Operating Fund
Fund: 8300

Contact Information:

Brian Blum, Assistant Director HPW/PFW (832) 395-2717

ATTACHMENTS:

Description	Type
Prior Motion	Backup Material
Prior Motion 2023-0048	Backup Material
Invoices	Backup Material
Form A	Financial Information
Agreement	Backup Material

Ownership Information
Tax Form
Conflict of Interest
S28794 signed coversheet
S28794.A1 signed coversheet

Backup Material
Backup Material
Backup Material
Backup Material
Backup Material



CITY OF HOUSTON - CITY COUNCIL

Meeting Date: 9/24/2024

District B

Item Creation Date: 5/28/2024

HPW – 20INF2427 Contractual Agreement for Right-of-Way Utility Adjustments / Sunoco Pipeline L.P. and ETP Crude LLC

Agenda Item#: 35.

Summary:

ORDINANCE appropriating \$1,412,558.00 out of Dedicated Drainage and Street Renewal Capital Fund – Ad Valorem Tax; approving and authorizing agreement for Right-of-Way Utility Adjustments between City of Houston, **SUNOCO PIPELINE L.P.**, and **ETP CRUDE LLC** for relocation of two 8-inch pipelines to accommodate the widening of Greens Road; providing funding for CIP Cost Recovery - **DISTRICT B - JACKSON**

Background:

SUBJECT: Contractual Agreement for Right-of-Way Utility Adjustments between the City of Houston, Sunoco Pipeline L.P., and ETP Crude LLC for Greens Road from John F. Kennedy Boulevard to US 59.

RECOMMENDATION: Adopt an ordinance approving and authorizing a Contractual Agreement for Right-of-Way Utility Adjustments between the City of Houston, Sunoco Pipeline L.P., and ETP Crude LLC and appropriate funds.

LOCATION: The project area is generally bound by Hardy Toll Road on the north, Beltway 8 on the south, Aldine Westfield Road on the east, and US 59 on the west.

SCOPE OF THE AGREEMENT AND FEE: The agreement between the City of Houston, Sunoco Pipeline L.P., and ETP Crude LLC entails the dual relocation of two 8-inch pipelines to accommodate the widening of Greens Road. Upon approval of the agreement by Council, a Notice to Proceed will be issued to both Sunoco Pipeline L.P. and ETP Crude LLC to begin their relocation. The City will not be responsible for cost exceeding \$1,345,293.14.

The total requested amount of \$1,412,558.00 is to be appropriated as follows: \$1,345,293.14 for cost of the project and \$67,264.86 CIP Cost Recovery.

FISCAL NOTE: No significant Fiscal Operating Impact is anticipated as a result of this project.

Randall V. Macchi, Chief Operating Officer

WBS No. N-000664-0002-7

Amount and Source of Funding:

\$1,412,558.00 from Fund No. 4046 – Dedicated Drainage and Street Renewal Capital Fund - Ad Valorem Tax

Contact Information:

<u>Name</u>	<u>Service Line</u>	<u>Contact Number</u>
Roberto Medina, Interim Chief of Staff	DO-HPW Government Relations	832.395.2456
Maria Perez, HPW Agenda Coordinator	DO-HPW Government Relations	832.395.2282
Tanu Hiremath, P.E., CFM, ENV SP Assistant Director	HPW Capital Projects	832.395.2291

ATTACHMENTS:

Description

Signed Coversheet
Maps

Type

Signed Cover sheet
Backup Material



CITY OF HOUSTON - CITY COUNCIL

Meeting Date: 9/24/2024

District B

Item Creation Date: 5/28/2024

HPW – 20INF2427 Contractual Agreement for Right-of-Way Utility Adjustments / Sunoco Pipeline L.P. and ETP Crude LLC

Agenda Item#: 3.

Background:

SUBJECT: Contractual Agreement for Right-of-Way Utility Adjustments between the City of Houston, Sunoco Pipeline L.P., and ETP Crude LLC for Greens Road from John F. Kennedy Boulevard to US 59.

RECOMMENDATION: Adopt an ordinance approving and authorizing a Contractual Agreement for Right-of-Way Utility Adjustments between the City of Houston, Sunoco Pipeline L.P., and ETP Crude LLC and appropriate funds.

LOCATION: The project area is generally bound by Hardy Toll Road on the north, Beltway 8 on the south, Aldine Westfield Road on the east, and US 59 on the west.

SCOPE OF THE AGREEMENT AND FEE: The agreement between the City of Houston, Sunoco Pipeline L.P., and ETP Crude LLC entails the dual relocation of two 8-inch pipelines to accommodate the widening of Greens Road. Upon approval of the agreement by Council, a Notice to Proceed will be issued to both Sunoco Pipeline L.P. and ETP Crude LLC to begin their relocation. The City will not be responsible for cost exceeding \$1,345,293.14.

The total requested amount of \$1,412,558.00 is to be appropriated as follows: \$1,345,293.14 for cost of the project and \$67,264.86 CIP Cost Recovery.

FISCAL NOTE: No significant Fiscal Operating Impact is anticipated as a result of this project.

DocuSigned by:

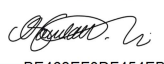
 9/6/2024
BE463EF0DF454EB...
Randall V. Macchi, Chief Operating Officer

WBS No. N-000664-0002-7

Amount and Source of Funding:

\$1,412,558.00 from Fund No. 4046 – Dedicated Drainage and Street Renewal Capital Fund - Ad Valorem Tax

Contact Information:

<u>Name</u>	<u>Service Line</u>	<u>Contact Number</u>
Roberto Medina, Interim Chief of Staff	DO-HPW Government Relations	832.395.2456
Maria Perez, HPW Agenda Coordinator	DO-HPW Government Relations	832.395.2282
Tanu Hiremath, P.E., CFM, ENV SP Assistant Director	HPW Capital Projects	832.395.2291

ATTACHMENTS:

Description	Type
SAP Documents	Financial Information
Maps	Backup Material

FILE PATH: L:\Legacy\USHOU1FS001\Prod\Projects\PWD\City Of Houston\60331306 - GreensRD-East\Phase-2\900 Cadd\Exhibits\240417 Greens Rd Vicinity Map\60331306-Vicinity_Map_Exhibit.dwg PLOTTED: 4/18/2024 10:32 AM PLOT STYLE: COH.ctb



PROJECT LOCATION

APPROXIMATE LOCATION OF EX SUNOCO PIPELINES

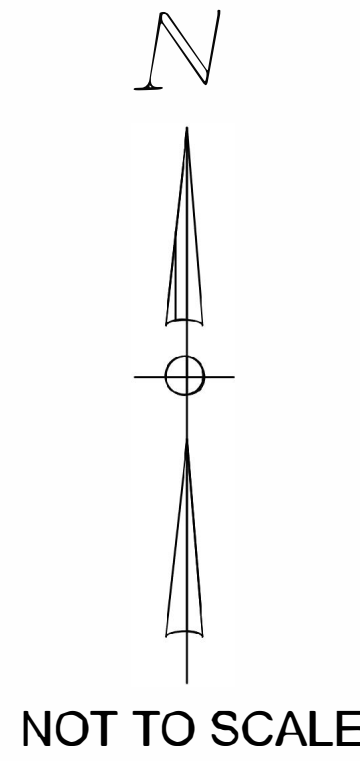

VICINITY MAP
NTS
KEY MAP NO. 374P, Q, R, 375N

GREENS ROAD (JFK BLVD TO US 59)
COUNCIL DISTRICT B
KEY MAP PAGE & GRID 374P,Q,R, 375N



19219 KATY FREEWAY
SUITE 100
HOUSTON, TX 77094
TEL: 281-646-2400
TBPE REG NO. F-3580

SCALE: NOT TO SCALE | WBS NO.: N-000664-0002-7 | DATE: APRIL, 2024

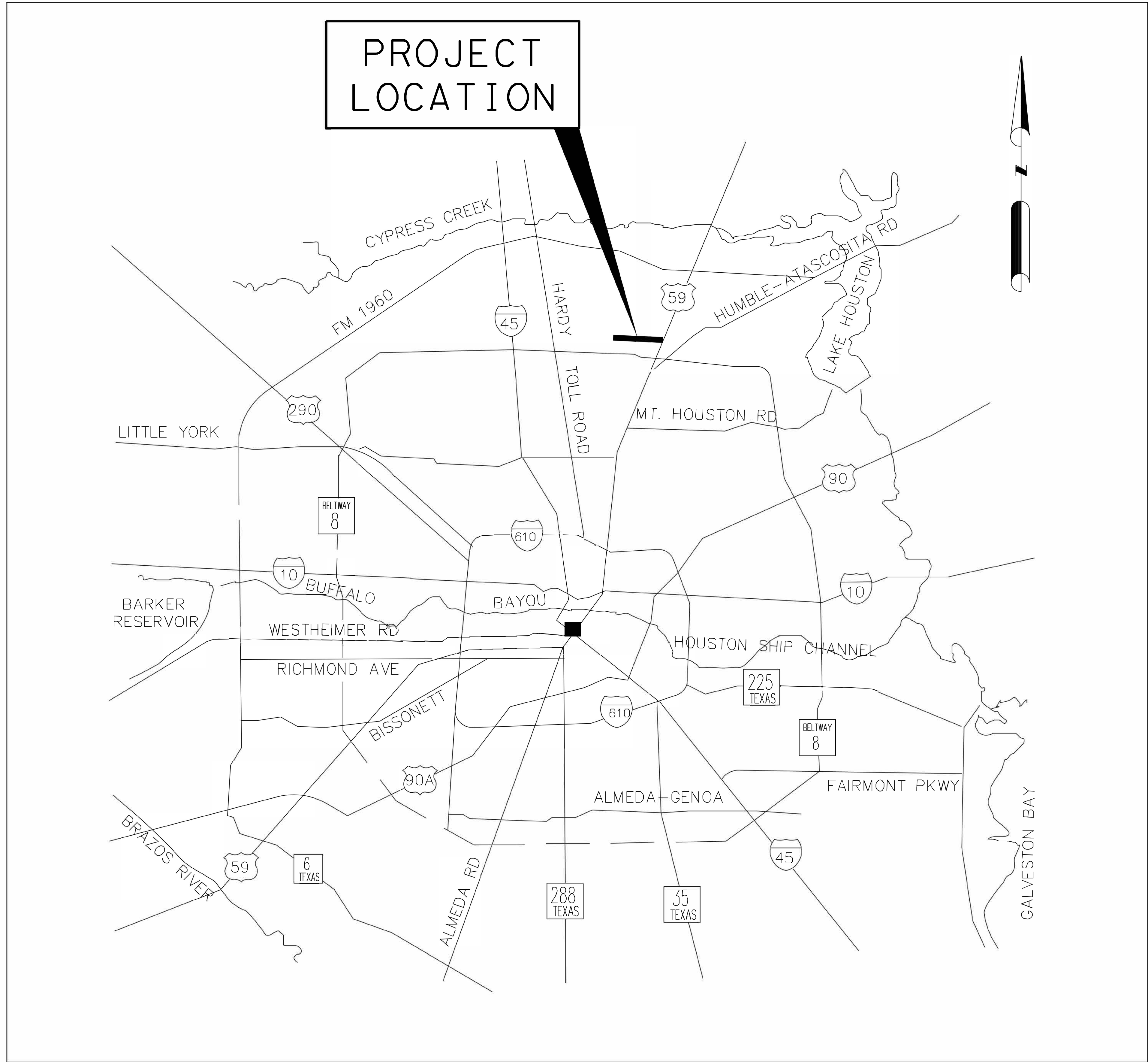

PROJECT
LOCATION

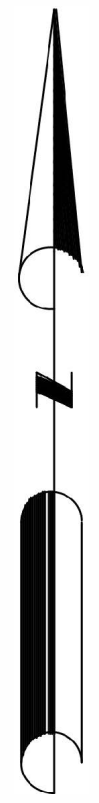

LOCATION MAP
NTS

GREENS ROAD (JFK BLVD TO US 59)
COUNCIL DISTRICT B
KEY MAP PAGE & GRID 374P,Q,R, 375N



19219 KATY FREEWAY
SUITE 100
HOUSTON, TX 77094
TEL: 281-646-2400
TBPE REG NO. F-3580



CITY OF HOUSTON - CITY COUNCIL

Meeting Date: 9/24/2024

ALL

Item Creation Date: 5/16/2024

HPW – 20MSD11 PS / Tanko Streetlighting, Inc.

Agenda Item#: 36.

Summary:

ORDINANCE awarding Professional Services Contract to **TANKO STREETLIGHTING, INC** for Nationwide Streetlight Ownership and Maintenance Plan for Houston Public Works; providing a maximum contract amount - 2 Years with 2 one-year options - \$265,552.00 - Dedicated Drainage and Street Renewal Fund – Metro et al

Background:

20MSD11 – Approve an ordinance awarding a professional services contract to Tanko Streetlighting, Inc. in the maximum contract amount not to exceed \$265,552.00 for a nationwide streetlighting ownership and maintenance plan for Houston Public Works.

SPECIFIC EXPLANATION: The Chief Operating Officer of Houston Public Works and the Chief Procurement Officer recommend that City Council approve an ordinance awarding a professional services contract to **Tanko Streetlighting, Inc.** for a **two-year term with two one-year options** to renew for a nationwide streetlighting ownership and maintenance plan in the maximum contract amount not to exceed **\$265,552.00** for Houston Public Works.

This project is part of the Transportation and Drainage Operations program and is required to assess and evaluate the City's streetlight model. It consists of conducting nationwide research on streetlight ownership and maintenance models of similar-sized municipalities and local government agencies and composing a report on the advantages and disadvantages of the City's current model to provide recommendations.

Under the scope of the Contract, the Consultant will perform Phase I Services. Phase I is based on the cost of time and materials with a not-to-exceed agreed-upon amount.

This recommendation is made pursuant to subsection 252.022(a)(4) of the Texas Local Government Code, which provides that "a procurement for personal, professional, or planning services" is exempt from the competitive requirements for purchases.

M/WBE Participation: The standard M/WBE goal set for the project is 26.00%. The Consultant has proposed a 26.36% M/WBE plan to meet the goal.

<u>Name of Firm</u>	<u>Work Description</u>	<u>Amount</u>	<u>% of Total Contract</u>
1. Van Brunt &	Needs assessment	<u>\$70,000.00</u>	<u>26.36%</u>

Associates, Inc. support, data collection

TOTAL

\$70,000.00

26.36%

HIRE HOUSTON FIRST: This procurement is exempt from the City's Hire Houston First (HHF) Ordinance. Bids/proposals were not solicited because the department is utilizing a professional services contractor for this contract.

PAY OR PLAY PROGRAM: The proposed contract requires compliance with the City's 'Pay or Play' ordinance regarding health benefits for employees of City contractors. In this case, the Consultant has elected to pay into the Contractor Responsibility Fund in compliance with City policy.

FISCAL NOTE: Funding for this item is included in the FY2025 Adopted Budget. Therefore, no Fiscal Note is required as stated in the Financial Policies.

Jedediah Greenfield
Chief Procurement Officer

Randall V. Macchi, Chief Operating Officer
Houston Public Works

Estimated Spending Authority			
Department	Current FY25	Out Years	Total
Houston Public Works	\$265,552.00	\$0.00	\$265,552.00

Amount and Source of Funding:

\$265,552.00

Dedicated Drainage and Street Renewal Fund – Metro et al
Fund 2312

Contact Information:

<u>Name</u>	<u>Service Line</u>	<u>Contact Number</u>
Roberto Medina, Interim Chief of Staff	DO-HPW Government Relations	832.395.2456
Maria Perez, HPW Agenda Coordinator	DO-HPW Government Relations	832.395.2282
Akhter Hussain, Supervising Engineer	HPW Houston Water	832.395.2294
Jedediah Greenfield, Chief Procurement Officer	Finance/SPD	832-393-9126

ATTACHMENTS:

Description

Signed Coversheet

Type

Signed Cover sheet



CITY OF HOUSTON - CITY COUNCIL

Meeting Date:

ALL

Item Creation Date: 5/16/2024

HPW – 20MSD11 PES / Tanko Streetlighting, Inc.

Agenda Item#:

Background:

20MSD11 – Approve an ordinance awarding a professional services contract to Tanko Streetlighting, Inc. in the maximum contract amount not to exceed \$265,552.00 for a nationwide streetlighting ownership and maintenance plan for Houston Public Works.

SPECIFIC EXPLANATION: The Chief Operating Officer of Houston Public Works and the Chief Procurement Officer recommend that City Council approve an ordinance awarding a professional services contract to **Tanko Streetlighting, Inc.** for a **two-year term with two one-year options** to renew for a nationwide streetlighting ownership and maintenance plan in the maximum contract amount not to exceed **\$265,552.00** for Houston Public Works.

This project is part of the Transportation and Drainage Operations program and is required to assess and evaluate the City’s streetlight model. It consists of conducting nationwide research on streetlight ownership and maintenance models of similar-sized municipalities and local government agencies and composing a report on the advantages and disadvantages of the City’s current model to provide recommendations.

Under the scope of the Contract, the Consultant will perform Phase I Services. Phase I is based on the cost of time and materials with a not-to-exceed agreed-upon amount.

This recommendation is made pursuant to subsection 252.022(a)(4) of the Texas Local Government Code, which provides that “a procurement for personal, professional, or planning services” is exempt from the competitive requirements for purchases.

M/WBE Participation: The standard M/WBE goal set for the project is 26.00%. The Consultant has proposed a 26.36% M/WBE plan to meet the goal.

<u>Name of Firm</u>	<u>Work Description</u>	<u>Amount</u>	<u>% of Total Contract</u>
1. Van Brunt & Associates, Inc.	Needs assessment support, data collection	\$70,000.00	26.36%
TOTAL		\$70,000.00	26.36%

HIRE HOUSTON FIRST: This procurement is exempt from the City’s Hire Houston First (HHF) Ordinance. Bids/proposals were not solicited because the department is utilizing a professional services contractor for this contract.

PAY OR PLAY PROGRAM: The proposed contract requires compliance with the City’s ‘Pay or Play’ ordinance regarding health benefits for employees of City contractors. In this case, the Consultant has elected to pay into the Contractor Responsibility Fund in compliance with City policy.

FISCAL NOTE: Funding for this item is included in the FY2025 Adopted Budget. Therefore, no Fiscal Note is required as stated in the Financial Policies.

DocuSigned by:

 6121834A077C41A...

Jedediah Greenfield
 Chief Procurement Officer

DocuSigned by:

 BE463EF0DF454EB...

Randall V. Macchi, Chief Operating Officer
 Houston Public Works

Estimated Spending Authority			
Department	Current FY25	Out Years	Total
Houston Public Works	\$265,552.00	\$0.00	\$265,552.00

Amount and Source of Funding:

\$265,552.00

Dedicated Drainage and Street Renewal Fund – Metro et al
Fund 2312

Contact Information:

<u>Name</u>	<u>Service Line</u>	<u>Contact Number</u>
Roberto Medina, Interim Chief of Staff	DO-HPW Government Relations	832.395.2456
Maria Perez, HPW Agenda Coordinator	DO-HPW Government Relations	832.395.2282
Akhter Hussain, Supervising Engineer	HPW Houston Water	832.395.2294
Jedediah Greenfield, Chief Procurement Officer	Finance/SPD	832-393-9126

ATTACHMENTS:

Description

SAP Documents
Map
OBO Documents
Form B
Ownership Information Form and Tax Report
Pay or Play
Form 1295

Type

Financial Information
Backup Material
Backup Material
Backup Material
Backup Material
Backup Material
Backup Material



CITY OF HOUSTON - CITY COUNCIL

Meeting Date: 9/24/2024

District B

Item Creation Date: 6/7/2024

HPW – 20FAC2452 PES / Lockwood, Andrews & Newnam,
Inc.

Agenda Item#: 37.

Summary:

ORDINANCE appropriating \$4,454,854.00 out of Water & Sewer System Consolidated Construction Fund; approving and authorizing Professional Engineering Services Contract between City of Houston and **LOCKWOOD, ANDREWS & NEWNAM, INC** for Capacity Remedial Measures Plan (CRMP) Package 8 – Area 1 – Basin IB043; providing funding for CIP Cost Recovery relating to construction of facilities financed by the Water & Sewer System Consolidated Construction Fund - **DISTRICT B - JACKSON**

Background:

SUBJECT: Professional Engineering Services Contract between the City and Lockwood, Andrews & Newnam, Inc. for Capacity Remedial Measures Plan (CRMP) Package 8 - Area 1 - Basin IB043.

RECOMMENDATION: An ordinance approving a Professional Engineering Services Contract with Lockwood, Andrews & Newnam, Inc. for Capacity Remedial Measures Plan (CRMP) Package 8 - Area 1 - Basin IB043 and appropriate funds.

PROJECT NOTICE/JUSTIFICATION: This project is part of the Capital Improvement Plan (CIP) and is required to develop and provide mitigation recommendations for the Capacity Remedial Measures Plan (CRMP).

The work to be performed under this contract award is necessary to maintain compliance with Houston's wastewater consent decree with the EPA and TCEQ.

DESCRIPTION/SCOPE: This project consists of the design of 84-inch diameter gravity sanitary sewer in Area 1 within sanitary sewer Basin IB043.

LOCATION: The project area is generally bound by Denmark Street on the north, and Pickfair Street on the south along Lockwood Drive.

SCOPE OF CONTRACT AND FEE: Under the scope of the Contract, the Consultant will perform Phase I - Preliminary Design, Phase II – Final Design, Phase III - Construction Phase Services and Additional Services. Basic Services Fee for Phase I is based on cost of time and materials with a not-to-exceed agreed upon amount. The Basic Services fees for Phase II and Phase III are based on a negotiated lump sum amount. The total Basic Services appropriation is \$2,487,773.00.

The Contract also includes certain Additional Services to be paid either as a lump sum or on a reimbursable basis. The total Additional Services appropriation is \$1,754,945.00.

The negotiated maximum for Phase I Services is \$389,267.00.

The total cost of this project is \$4,454,854.00 to be appropriated as follows: \$4,242,718.00 for Contract services and \$212,136.00 for CIP Cost Recovery.

PAY OR PLAY PROGRAM: The proposed contract requires compliance with the City’s ‘Pay or Play’ ordinance regarding health benefits for employees of City contractors. In this case, the Consultant provides health benefits to eligible employees in compliance with City policy.

M/WBE PARTICIPATION: The standard M/WBE goal set for the project is 26.00%. The Consultant has proposed a 26.02% MWBE plan to meet the goal.

<u>Name of Firms</u>	<u>Work Description</u>	<u>Amount</u>	<u>% of Total Contract</u>
1. Associated Testing Laboratories, Inc.	Testing laboratories	\$ 275,000.00	6.48%
2. GRIS Engineering, dba Global Resilient Infrastructure Solutions	Civil engineering services	\$ 140,000.00	3.30%
3. InduSri Consulting, LLC	Civil engineering services	\$ 330,000.00	7.78%
4. ASV Consulting Group, Inc.	Engineering consulting services	\$ 64,000.00	1.51%
5. Landtech Inc., DBA Landtech Consultants, Inc.	Land surveying services	<u>\$ 295,000.00</u>	<u>6.95%</u>
TOTAL		\$1,104,000.00	26.02%

FISCAL NOTE: No significant Fiscal Operating impact is anticipated as a result of this project.

 Randall V. Macchi, Chief Operating Officer
 Houston Public Works

WBS No. R-001000-0033-3

Amount and Source of Funding:

\$4,454,854.00 from Fund No. 8500 – Water and Sewer System Consolidated Construction

Contact Information:

<u>Name</u>	<u>Service Line</u>	<u>Contact Number</u>
Roberto Medina, Interim Chief of Staff	DO-HPW Government Relations	832.395.2456
Maria Perez, HPW Agenda Coordinator	DO-HPW Government Relations	832.395.2282
Markos E. Mengesha P.E., CCM Assistant Director	HPW-Capital Projects	832.395.2356

ATTACHMENTS:

Description

Signed Coversheet

Maps

Type

Signed Cover sheet

Backup Material



CITY OF HOUSTON - CITY COUNCIL

Meeting Date:

District B

Item Creation Date: 6/7/2024

HPW – 20FAC2452 PES / Lockwood, Andrews & Newnam, Inc.

Agenda Item#:

Background:

SUBJECT: Professional Engineering Services Contract between the City and Lockwood, Andrews & Newnam, Inc. for Capacity Remedial Measures Plan (CRMP) Package 8 - Area 1 - Basin IB043.

RECOMMENDATION: An ordinance approving a Professional Engineering Services Contract with Lockwood, Andrews & Newnam, Inc. for Capacity Remedial Measures Plan (CRMP) Package 8 - Area 1 - Basin IB043 and appropriate funds.

PROJECT NOTICE/JUSTIFICATION: This project is part of the Capital Improvement Plan (CIP) and is required to develop and provide mitigation recommendations for the Capacity Remedial Measures Plan (CRMP).

The work to be performed under this contract award is necessary to maintain compliance with Houston's wastewater consent decree with the EPA and TCEQ.

DESCRIPTION/SCOPE: This project consists of the design of 84-inch diameter gravity sanitary sewer in Area 1 within sanitary sewer Basin IB043.

LOCATION: The project area is generally bound by Denmark Street on the north, and Pickfair Street on the south along Lockwood Drive.

SCOPE OF CONTRACT AND FEE: Under the scope of the Contract, the Consultant will perform Phase I - Preliminary Design, Phase II – Final Design, Phase III - Construction Phase Services and Additional Services. Basic Services Fee for Phase I is based on cost of time and materials with a not-to-exceed agreed upon amount. The Basic Services fees for Phase II and Phase III are based on a negotiated lump sum amount. The total Basic Services appropriation is \$2,487,773.00.

The Contract also includes certain Additional Services to be paid either as a lump sum or on a reimbursable basis. The total Additional Services appropriation is \$1,754,945.00.

The negotiated maximum for Phase I Services is \$389,267.00.

The total cost of this project is \$4,454,854.00 to be appropriated as follows: \$4,242,718.00 for Contract services and \$212,136.00 for CIP Cost Recovery.

PAY OR PLAY PROGRAM: The proposed contract requires compliance with the City's 'Pay or Play' ordinance regarding health benefits for employees of City contractors. In this case, the Consultant provides health benefits to eligible employees in compliance with City policy.

MWBE PARTICIPATION: The standard MWBE goal set for the project is 26.00%. The Consultant has proposed a 26.02% MWBE plan to meet the goal.

Name of Firms	Work Description	Amount	% of Total Contract
1. Associated Testing Laboratories, Inc.	Testing laboratories	\$ 275,000.00	6.48%
2. GRIS Engineering, dba Global Resilient Infrastructure Solutions	Civil engineering services	\$ 140,000.00	3.30%
3. InduSri Consulting, LLC	Civil engineering services	\$ 330,000.00	7.78%
4. ASV Consulting Group, Inc.	Engineering consulting services	\$ 64,000.00	1.51%
5. Landtech Inc., DBA Landtech Consultants, Inc.	Land surveying services	<u>\$ 295,000.00</u>	<u>6.95%</u>
TOTAL		\$1,104,000.00	26.02%

-

FISCAL NOTE: No significant Fiscal Operating impact is anticipated as a result of this project.

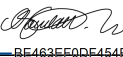
DocuSigned by:

BE4635E0DF454EB

9/9/2024

Randall V. Macchi, Chief Operating Officer
Houston Public Works

WBS No. R-001000-0033-3

Amount and Source of Funding:

\$4,454,854.00 from Fund No. 8500 – Water and Sewer System Consolidated Construction

Contact Information:

<u>Name</u>	<u>Service Line</u>	<u>Contact Number</u>
Roberto Medina, Interim Chief of Staff	DO-HPW Government Relations	832.395.2456
Maria Perez, HPW Agenda Coordinator	DO-HPW Government Relations	832.395.2282
Markos E. Mengesha P.E., CCM Assistant Director	HPW-Capital Projects	832.395.2356

ATTACHMENTS:

Description	Type
SAP Documents	Financial Information
Maps	Backup Material
OBO docs	Backup Material
Form B	Backup Material
Ownership Information Form & Tax Report	Backup Material
Pay or Play	Backup Material
Form 1295	Backup Material



HOUSTON PUBLIC WORKS

PROPOSED PROJECT LOCATION MAP

WBS NO. R-001000-0033-3

CAPACITY REMEDIAL MEASURES
PLAN (CRMP) PACKAGE 8 - AREA 1

KEY MAP GRID(S): 454U, Q, L, G, C, B & X
COUNCIL DISTRICT(S): B



1 IN = 15,000 FT

Legend

- █ PROPOSED 84" PARALLEL TRUNK (PACKAGE 6): APPROX. 7,900 LF
- █ PROPOSED 84" PARALLEL TRUNK (PACKAGE 7): APPROX. 7,200 LF
- █ PROPOSED 84" PARALLEL TRUNK (PACKAGE 8): APPROX. 8,000 LF (THIS PROJECT)
- █ COUNCIL DISTRICT A
- █ COUNCIL DISTRICT B
- █ COUNCIL DISTRICT C
- █ COUNCIL DISTRICT D
- █ COUNCIL DISTRICT E
- █ COUNCIL DISTRICT F
- █ COUNCIL DISTRICT G
- █ COUNCIL DISTRICT H
- █ COUNCIL DISTRICT I
- █ COUNCIL DISTRICT J
- █ COUNCIL DISTRICT K



**Lockwood, Andrews
& Newnam, Inc.**
A LEO A DALY COMPANY

TBPE Firm No. 2614

2925 Briarpark Drive • Houston, TX 77042-3720
T 713.266.6900 • F 713.266.2089
www.lan-inc.com • info@lan-inc.com

5/14/2024

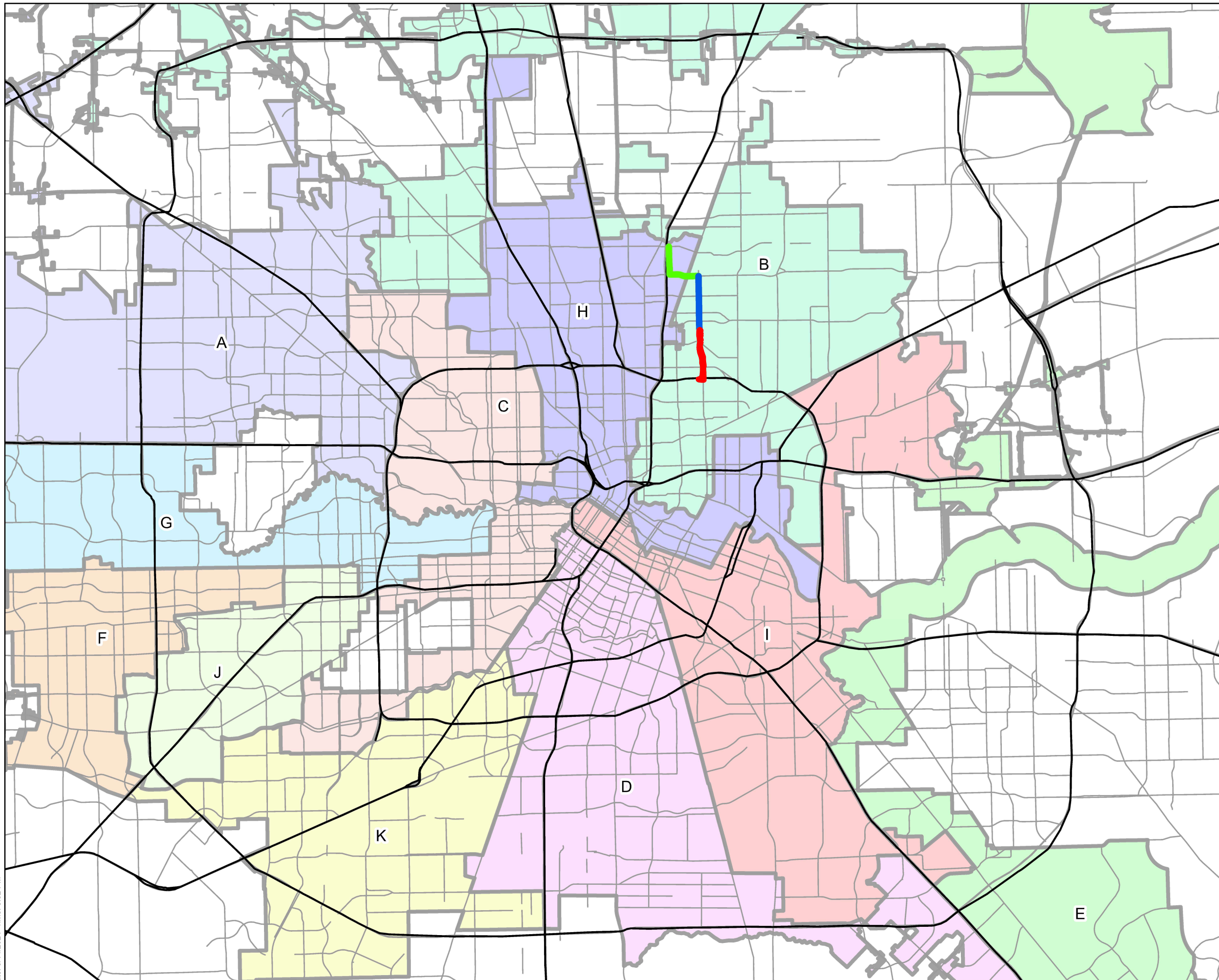

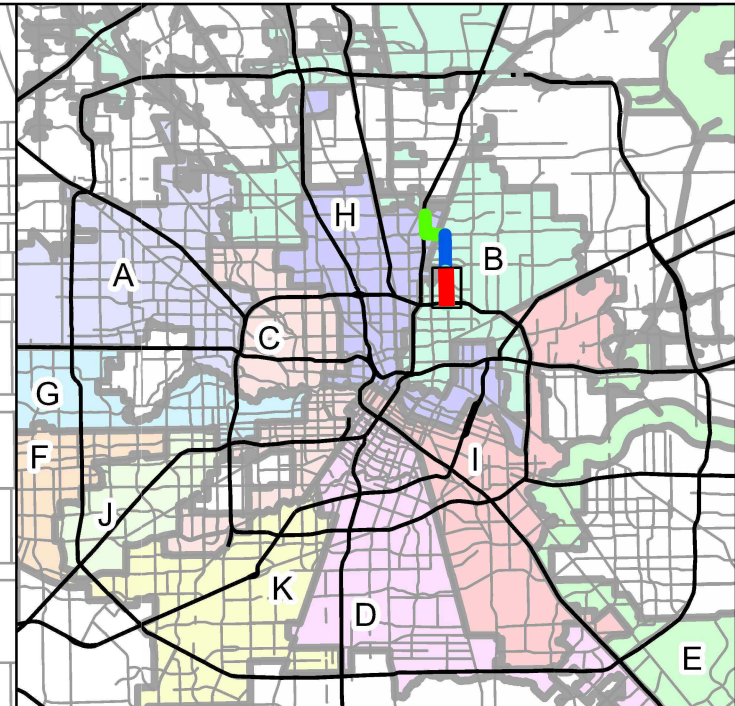
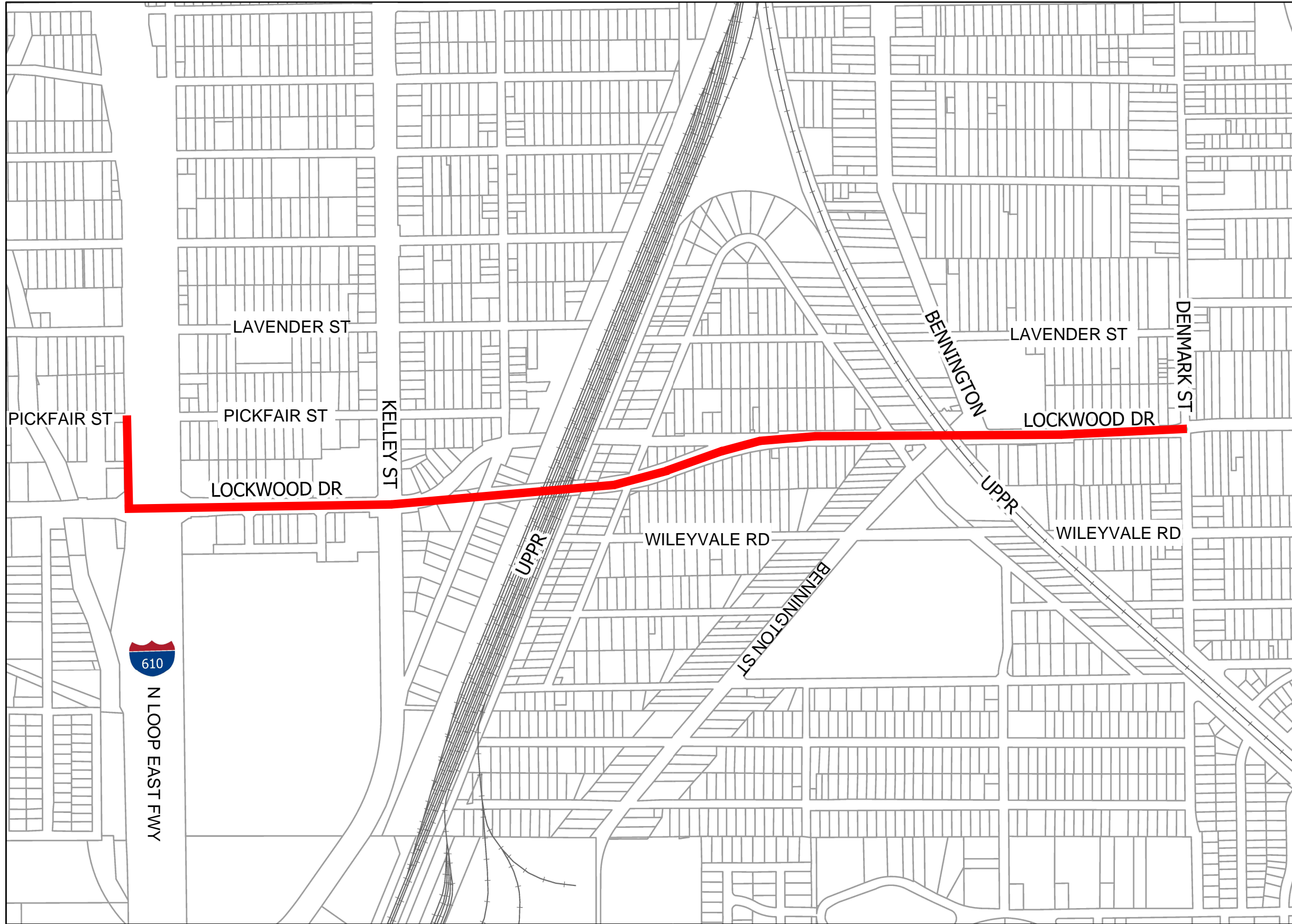

KEY GRID #: 454L, 454Q, & 454U
 COUNCIL DISTRICT: B

PROJECT LOCATION MAP

Legend

 **CRMP PACKAGE 8 - AREA 1
 PROPOSED 84-INCH
 GRAVITY SEWER**

CITY OF HOUSTON
 CAPACITY REMEDIAL MEASURES PLAN (CRMP) PACKAGE 8 - AREA 1
 WBS NO. R-001000-0033-3

VICINITY MAP

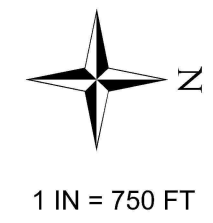

APPROVED: GJH
 CHECKED: BA
 PREPARED: GRS

lan Lockwood, Andrews & Newnam, Inc.
 A LEO A DALY COMPANY
 TBPE Firm No. 2614
 2925 Briarpark Drive • Houston, TX 77042-3720
 T 713.266.6900 • F 713.266.2089
 www.lan-inc.com • info@lan-inc.com

5/15/2024

C:\Users\GFSchulz\OneDrive - LEO A DALY\Computer\Profile\Desktop\CPMRP Package 8 - Area 1\CPMRP Package 8 - Area 1.aprx
 Date: 5/15/2024 Time: 9:16 AM



CITY OF HOUSTON - CITY COUNCIL

Meeting Date: 9/24/2024

District I

Item Creation Date: 5/22/2024

HPW – 20WWP10 Amendment / Omega Engineers, Inc.

Agenda Item#: 38.

Summary:

PULLED - This item will not be considered on Wednesday September 25

ORDINANCE appropriating \$1,376,874.75 out of Water & Sewer System Consolidated Construction Fund; approving and authorizing first amendment to Professional Engineering Services Contract between City of Houston and **OMEGA ENGINEERS, INC** for Work Order Engineering Services for Capacity Remedial Measures Plan for Package #2 (as approved by Ordinance No. 2021-0244) - **DISTRICT I - MARTINEZ**

Background:

SUBJECT: First Amendment to the Professional Engineering Services contract between the City and Omega Engineers, Inc. for Work Order Engineering Services for Capacity Remedial Measures Plan (CRMP) for Package 02.

RECOMMENDATION: Approve the First Amendment to the Professional Engineering Services contract with Omega Engineers, Inc. and appropriate funds.

PROJECT NOTICE/JUSTIFICATION: This project is part of the CRMP for the City of Houston and is required to identify improvements necessary to address Recognized Capacity Constraints Areas (RCCAs). The work to be performed under this contract is necessary to maintain compliance with Houston's proposed wastewater consent decree with the EPA and TCEQ.

DESCRIPTION/SCOPE: The project is located within the Sims Bayou North and Sims Bayou South Wastewater Treatment Plant (WWTP) Service Areas for different capacity constraint areas including but not limited to Areas 5 (Upstream of Eddington Area), 6 (Downstream of Eddington Area), Area 7 (YMCA Area in Sims Bayou) and Area 10 (Wheeler-Telephone Road Area). The consultant shall provide services related to the CRMP, prepare engineering and technical documentation and collaborate with the City of Houston and its contractors.

LOCATION: The project area is in the City of Houston generally bound by Polk Street on the north, Interstate 610 on the south, Broadway Street on the east and Mykawa Rd on the west.

PREVIOUS HISTORY AND SCOPE: City Council approved the original contract on April 07, 2021 under Ordinance No. 2021-0244. The scope of services under the original contract consisted of evaluating the capacity of the existing Wastewater Collection and Transmission Systems (WCTS) within the study area. In addition, the scope of services included the consultant identifying improvements necessary to address RCCAs to be implemented immediately and identifying improvements in the WCTS that are hydraulically connected to the RCCAs, which would be implemented in future phases as set forth in the wastewater consent decree with the EPA and TCEQ. The scope of work under this work order contract also consisted of the consultant performing Phase I - Preliminary Engineering Services based on the cost of time and materials with a not-to-exceed agreed upon amount.

Under this contract, the Consultant has accomplished identification of capacity constraints areas for the Sims Bayou WWTP and Sims Bayou South Service areas and recommended resolutions that generated two (2) Houston Public Works Capital Projects for an estimated construction cost of \$44 million. These projects have been submitted to the EPA for approval on schedule as per Consent Decree and transferred to Houston Public Works Capital Projects to complete design and construction phases. Houston Public Works Capital Projects has selected an Engineer of

Record (EOR) for each project.

SCOPE OF THIS AMENDMENT AND FEE: Under the scope of this First Amendment, the Consultant will accomplish the following: Since the transfer of the previously mentioned projects to Houston Public Works Capital Projects, the need has been identified to keep the CRMP consultant until the EORs complete design phases. The CRMP consultant will be responsible to provide required communication and bridge services to all EORs and the City of Houston so that all recommended projects, as submitted to the EPA under the Consent Decree, would stay in their scope, budget and schedule. During Phase I - Preliminary Design and Phase II – Final Design, CRMP consultant will participate with the Stakeholders, EORs, and other agencies as needed.

The total requested appropriation for contract services is \$1,376,874.75.

PAY OR PLAY PROGRAM: The proposed contract requires compliance with the City's 'Pay or Play' ordinance regarding health benefits for employees of City Contractors. In this case, the Contractor provides health benefits to eligible employees in compliance with City policy.

M/WBE PARTICIPATION: The M/WBE goal advertised for this project was 24.00%. The original contract amount totals \$1,431,210.00. The Consultant has been paid \$1,188,870.00 (83.07%). Of this amount, \$389,025.00 (32.72%) has been paid to M/WBE sub-contractors to date. Assuming approval of the requested additional appropriation, the contract amount will increase to \$2,808,084.75. The Office of Business Opportunity will continue to monitor this contract for M/WBE compliance. The Consultant proposes the following plan to meet the M/WBE goal.

<u>Name of Firms</u>	<u>Work Description</u>	<u>Amount</u>	<u>% of Total Contract</u>
Paid Prior M/WBE Commitment		\$389,025.00	13.85%
Unpaid Prior M/WBE Commitment		\$143,957.60	5.13%
1. Red Fox Infrastructure Inc.	Computer Aided Design for Engineering projects	\$357,987.44	12.75%
	TOTAL	<u>\$890,970.04</u>	<u>31.73%</u>

FISCAL NOTE: No significant Fiscal Operating impact is anticipated as a result of this project.

Randy Macchi, Chief Operating Officer
Houston Public Works

WBS No. R-000020-0073-3

Prior Council Action:

Ordinance No. 2021-0244, dated 04-07-2021

Amount and Source of Funding:

\$1,376,874.75 - Fund No. 8500 - Water and Sewer System Consolidated Construction Fund

Original appropriation of \$1,502,770.50 from Fund No. 8500 – Water and Sewer System Consolidated Construction Fund.

Contact Information:

Name	Service Line	Contact No.
Roberto Medina, Interim Chief of Staff	DO-HPW Government Relations	832.395.2456
Maria Perez, HPW Agenda Coordinator	DO-HPW Government Relations	832.395.2282
Akhter Hussain, Supervising Engineer	HPW Houston Water	832.395.2294

ATTACHMENTS:

Description

Signed Coversheet
Maps

Type

Signed Cover sheet
Backup Material



CITY OF HOUSTON - CITY COUNCIL

Meeting Date:

District I

Item Creation Date: 5/22/2024

HPW – 20WWP10 Amendment / Omega Engineers, Inc.

Agenda Item#:

Background:

SUBJECT: First Amendment to the Professional Engineering Services contract between the City and Omega Engineering, Inc. for Work Order Engineering Services for Capacity Remedial Measures Plan (CRMP) for Package 02.

RECOMMENDATION: Approve the First Amendment to the Professional Engineering Services contract with Omega Engineers, Inc. and appropriate funds.

PROJECT NOTICE/JUSTIFICATION: This project is part of the CRMP for the City of Houston and is required to identify improvements necessary to address Recognized Capacity Constraints Areas (RCCAs). The work to be performed under this contract is necessary to maintain compliance with Houston's proposed wastewater consent decree with the EPA and TCEQ.

DESCRIPTION/SCOPE: The project is located within the Sims Bayou North and Sims Bayou South Wastewater Treatment Plant (WWTP) Service Areas for different capacity constraint areas including but not limited to Areas 5 (Upstream of Eddington Area), 6 (Downstream of Eddington Area), Area 7 (YMCA Area in Sims Bayou) and Area 10 (Wheeler-Telephone Road Area). The consultant shall provide services related to the CRMP, prepare engineering and technical documentation and collaborate with the City of Houston and its contractors.

LOCATION: The project area is in the City of Houston generally bound by Polk Street on the north, Interstate 610 on the south, Broadway Street on the east and Mykawa Rd on the west.

PREVIOUS HISTORY AND SCOPE: City Council approved the original contract on April 07, 2021 under Ordinance No. 2021-0244. The scope of services under the original contract consisted of evaluating the capacity of the existing Wastewater Collection and Transmission Systems (WCTS) within the study area. In addition, the scope of services included the consultant identifying improvements necessary to address RCCAs to be implemented immediately and identifying improvements in the WCTS that are hydraulically connected to the RCCAs, which would be implemented in future phases as set forth in the wastewater consent decree with the EPA and TCEQ. The scope of work under this work order contract also consisted of the consultant performing Phase I - Preliminary Engineering Services based on the cost of time and materials with a not-to-exceed agreed upon amount.

Under this contract, the Consultant has accomplished identification of capacity constraints areas for the Sims Bayou WWTP and Sims Bayou South Service areas and recommended resolutions that generated two (2) Houston Public Works Capital Projects for an estimated construction cost of \$44 million. These projects have been submitted to the EPA for approval on schedule as per Consent Decree and transferred to Houston Public Works Capital Projects to complete design and construction phases. Houston Public Works Capital Projects has selected an Engineer of Record (EOR) for each project.

SCOPE OF THIS AMENDMENT AND FEE: Under the scope of this First Amendment, the Consultant will accomplish the following: Since the transfer of the previously mentioned projects to Houston Public Works Capital Projects, the need has been identified to keep the CRMP consultant until the EORs complete design phases. The CRMP consultant will be responsible to provide required communication and bridge services to all EORs and the City of Houston so that all recommended projects, as submitted to the EPA under the Consent Decree, would stay in their scope, budget and schedule. During Phase I - Preliminary Design and Phase II – Final Design, CRMP consultant will participate with the Stakeholders, EORs, and other agencies as needed.

The total requested appropriation for contract services is \$1,376,874.75.

PAY OR PLAY PROGRAM: The proposed contract requires compliance with the City's 'Pay or Play' ordinance regarding health benefits for employees of City Contractors. In this case, the Contractor provides health benefits to eligible employees in compliance with City policy.

M/WBE PARTICIPATION: The M/WBE goal advertised for this project was 24.00%. The original contract amount totals \$1,431,210.00. The Consultant has been paid \$1,188,870.00 (83.07%). Of this amount, \$389,025.00 (32.72%) has been paid to M/WBE sub-contractors to date. Assuming approval of the requested additional appropriation, the contract amount will increase to \$2,808,084.75. The Office of Business Opportunity will continue to monitor this contract for M/WBE compliance. The Consultant proposes the following plan to meet the M/WBE goal.

<u>Name of Firms</u>	<u>Work Description</u>	<u>Amount</u>	<u>% of Total Contract</u>
Paid Prior M/WBE Commitment		\$389,025.00	13.85%
Unpaid Prior M/WBE Commitment		\$143,957.60	5.13%
1. Red Fox Infrastructure Inc.	Computer Aided Design for Engineering projects	\$357,987.44	12.75%
TOTAL		<u>\$890,970.04</u>	<u>31.73%</u>

FISCAL NOTE: No significant Fiscal Operating impact is anticipated as a result of this project.

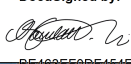
DocuSigned by:

 9/13/2024
 PE168EF0DF451EB
 Randy Macchi, Chief Operating Officer
 Houston Public Works

WBS No. R-000020-0073-3

Prior Council Action:

Ordinance No. 2021-0244, dated 04-07-2021

Amount and Source of Funding:

\$1,376,874.75 - Fund No. 8500 - Water and Sewer System Consolidated Construction Fund

Original appropriation of \$1,502,770.50 from Fund No. 8500 – Water and Sewer System Consolidated Construction Fund.

Contact Information:

Name	Service Line	Contact No.
Roberto Medina, Interim Chief of Staff	DO-HPW Government Relations	832.395.2456
Maria Perez, HPW Agenda Coordinator	DO-HPW Government Relations	832.395.2282
Akhter Hussain, Supervising Engineer	HPW Houston Water	832.395.2294

ATTACHMENTS:

Description	Type
SAP Documents	Financial Information
Maps	Backup Material
OBO Document	Backup Material
Form B	Backup Material
Ownership Information Form & Tax Report	Backup Material
Pay or Play	Backup Material
Form 1295	Backup Material
Prior Council Action	Backup Material

PROJECT LOCATION KEY MAP
 494X, 494Y, and 534C
 COUNCIL DISTRICT I
 COUNCILMEMBER
 JOAQUIN MARTINEZ

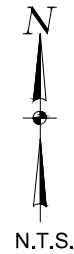
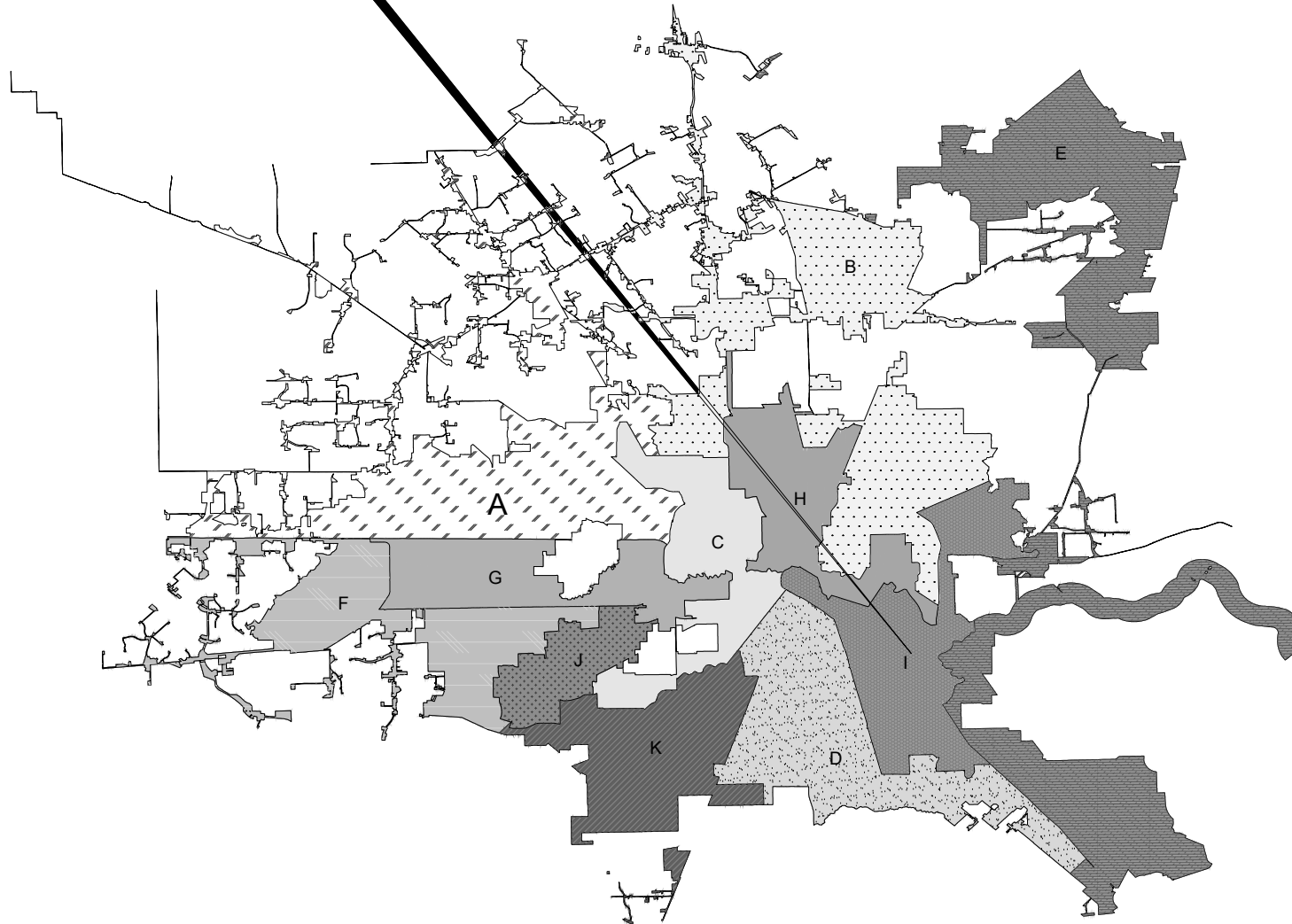

KEY MAP

HEMPSTEAD LS: 052
 KEY MAP-GRID: 451-J

COUNCIL DISTRICTS

- A - AMY PECK
- B - TARSHA JACKSON
- C - ABBIE KAMIN
- D - CAROLYN EVANS-SHABAZZ
- E - FRED FLICKINGER
- F - TIFFANY D. THOMAS
- G - MARY NAN HUFFMAN
- H - MARIO CASTILLO
- I - JOAQUIN MARTINEZ
- J - EDWARD POLLARD
- K - MARTHA CASTEX-TATUM

AT LARGE

- POS 1 - JULIAN RAMIREZ
- POS 2 - WILLIE DAVIS
- POS 3 - TWILA CARTER
- POS 4 - LETITIA PLUMMER
- POS 5 - SALLIE ALCORN

OMEGA ENGINEERS, INC. 16360 PARK TEN PLACE, Ste. #325
 HOUSTON TEXAS, 77064
 OMEGAENGINEERS.COM
 TX PE Firm Reg. No. F-2147
 P:281 647 9182 F:281 647 9184



Work Order Engineering Services for Capacity
 Remedial Measures Plan (CRMP) for Package 02

WBS No. # R-000020-0073-3

CITY COUNCIL DISTRICT MAP

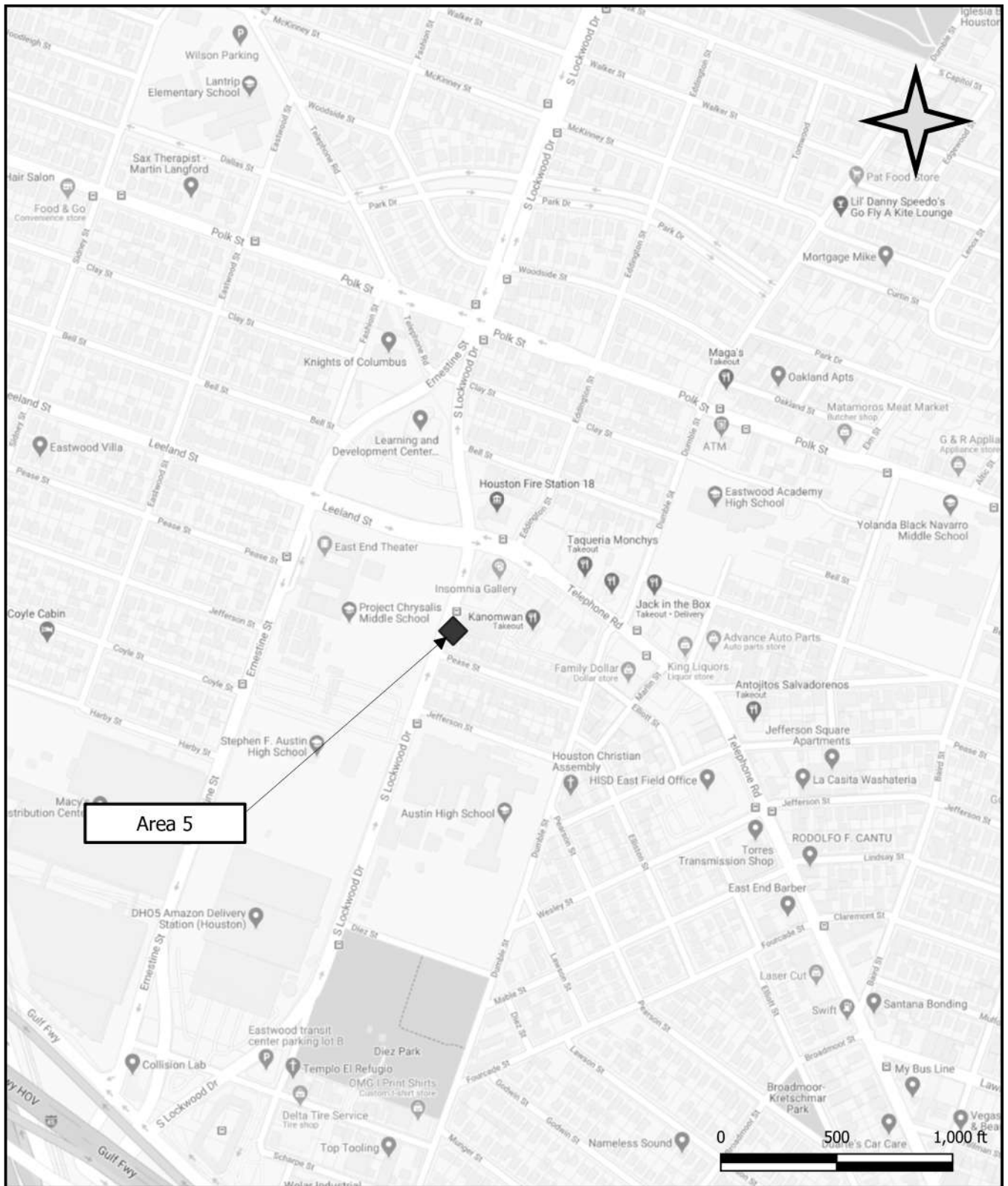

Vicinity Map - Area 5 - Downstream of Eddington Area

Work Order Engineering Services for Capacity Remedial Measures Plan (CRMP) for Package 02

Key Map Number - 494X
 District I
 Councilmember - Joaquin Martinez

WBS No. R-00020-0073-3 - Houston Public Works

OMEGA
 ENGINEERS, INC.

16360 PARK TEN PLACE, Ste. #325
 HOUSTON TEXAS, 77084
 OMEGAENGINEERS.COM
 TX PE Firm Reg. No. F-2147
 P: 281 647 9182 F: 281 647 9184



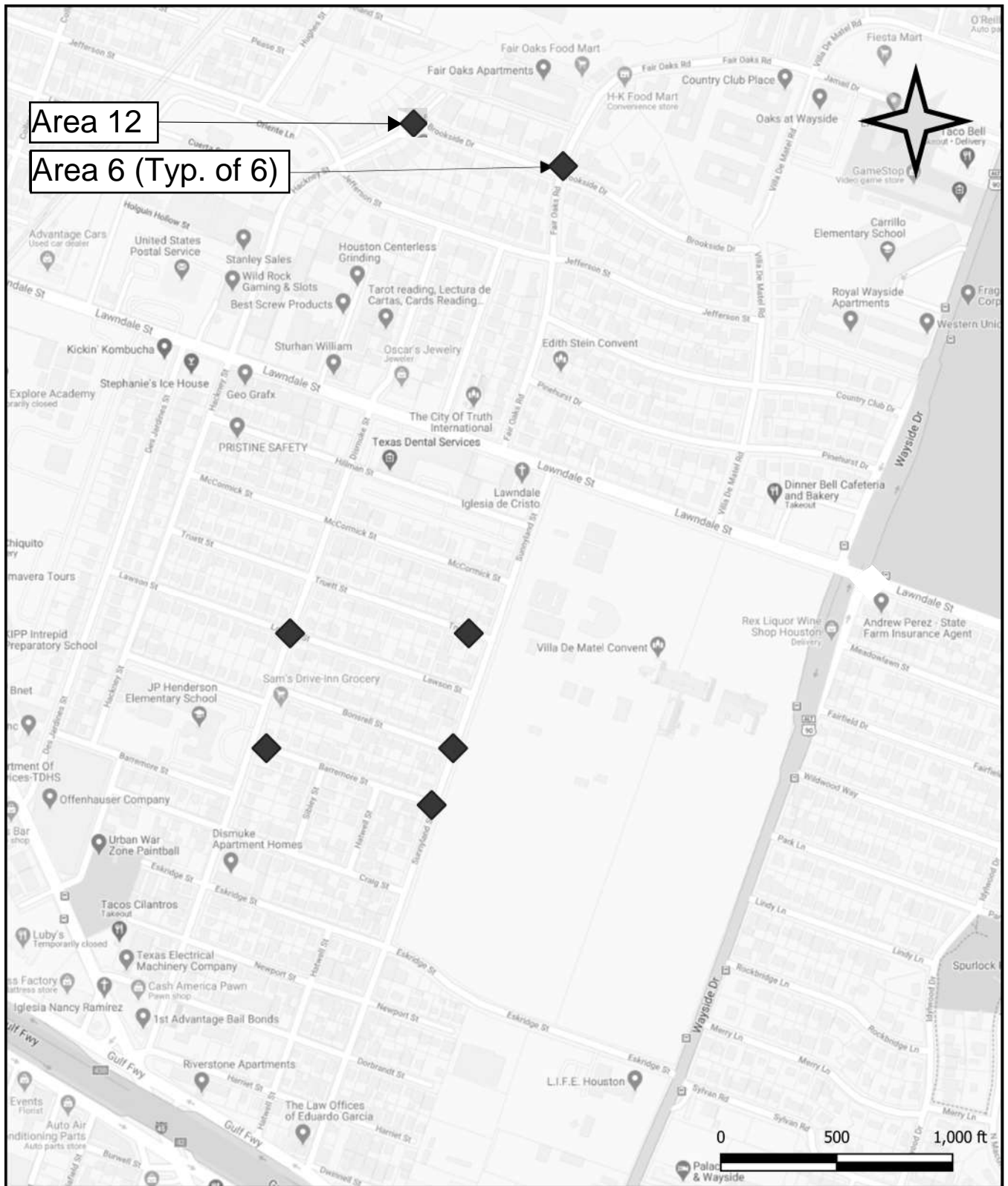

Vicinity Map -Areas 06/12 - Upstream of Eddington Area

Work Order Engineering Services for Capacity Remedial Measures Plan (CRMP) for Package 02

Key Map Number - 494Y and 534C
 District I
 Councilmember - Joaquin Martinez

WBS No. R-00020-0073-3 - Houston Public Works



16360 PARK TEN PLACE, Ste. #325
 HOUSTON TEXAS, 77084
 OMEGAENGINEERS.COM
 TX PE Firm Reg. No. F-2147
 P: 281 647 9182 F: 281 647 9184





CITY OF HOUSTON - CITY COUNCIL

Meeting Date: 9/24/2024

District I

Item Creation Date: 7/5/2024

HPW – 20FAC2458 Contract Award / Pate Garver, LP

Agenda Item#: 39.

Summary:

ORDINANCE appropriating \$33,740,000.00 out of Water & Sewer System Consolidated Construction Fund, awarding contract to **PATE GARVER, LP** for Easthaven WWTP Flow Diversion Package 1; setting a deadline for the bidder's execution of the contract and delivery of all bonds, insurance, and other required contract documents to the City; holding the bidder in default if it fails to meet the deadlines; providing funding for CIP Cost Recovery relating to construction of facilities financed by the Water & Sewer System Consolidated Construction Fund; contingency, testing services, and construction management - **DISTRICT I - MARTINEZ**

Background:

SUBJECT: Contract Award for Easthaven Wastewater Treatment Plant (WWTP) Flow Diversion Package 1.

RECOMMENDATION: Award a Construction Contract to Pate Garver, LP for Easthaven Wastewater Treatment Plant (WWTP) Flow Diversion Package 1 and appropriate funds.

PROJECT NOTICE/JUSTIFICATION: This project is part of the City's Capital Improvement Plan (CIP) Consolidation Package for wastewater facilities and is required to control operations and maintenance cost and ensure regulatory compliance

The work to be performed under this contract award is necessary to maintain compliance with the Houston's wastewater consent decree with EPA and TCEQ.

DESCRIPTION/SCOPE: This project consists of the construction of 54-inch and 60-inch gravity sanitary sewer lines by microtunnel construction method, including the installation of valves, connections, and appurtenances. The Contract duration for this project is 620 calendar days. This project was designed by IDS Engineering Group.

LOCATION: The project area is generally bound by Almeda Genoa Road on the north, Beltway 8 on the south, Beamer Road on the east, and Monroe Road on the west.

BIDS: This project was advertised for bidding on 02/16/2024. Bids were received on 03/21/2024. The five (5) bids are as follows:

	<u>Bidder</u>	<u>Bid Amount</u>
1.	Pate Garver, LP	\$29,787,458.57
2.	MC2 Civil LLC	\$30,988,155.00

2.	MOZ CIVIL, LLC	\$88,000,100.00
3.	Boyer, Inc.	\$31,676,142.00
4.	Reytec Construction	\$46,550,805.00
5.	HB Trenchless, LLC	\$49,471,086.00

AWARD: It is recommended that this construction contract be awarded to Pate Garver, LP with a low bid of \$29,787,458.57 and that Addendum Number 1 be made a part of this Contract.

PROJECT COST: The total cost of this project is \$33,740,000.00 to be appropriated as follows:

· Bid Amount	\$29,787,458.57
· Contingencies	\$ 1,489,372.93
· Testing Services	\$ 225,000.00
· CIP Cost Recovery	\$ 1,489,734.10
· Construction Management	\$ 748,434.40

Testing Services will be provided by Terracon Consultants, Inc. under a previously approved contract.

Construction Management Services will be provided by Plummer Associates under a previously approved contract.

HIRE HOUSTON FIRST: The proposed contract requires compliance with the City's 'Hire Houston First' (HHF) ordinance that promotes economic opportunity for Houston business and supports job creation. In this case, Pate Garver, LP is a designated HHF company, but they were the successful awardee without application of the HHF preference.

PAY OR PLAY PROGRAM: The proposed contract requires compliance with the City's 'Pay or Play' ordinance regarding health benefits for employees of City contractors. In this case, the Contractor provides health benefits to eligible employees in compliance with City policy.

M/WSBE PARTICIPATION: The contractor has submitted the following proposed program to satisfy the 13.00% MBE goal and 7.00% WBE goal for this project.

	<u>MBE - Name of Firms</u>	<u>Work Description</u>	<u>Amount</u>	<u>% of Contract</u>
1.	V&S Construction Company LLC	Installing Shafts	\$ 3,872,369.61	<u>13.00%</u>
		TOTAL	\$ 3,872,369.61	13.00%

	<u>WBE - Name of Firms</u>	<u>Work Description</u>	<u>Amount</u>	<u>% of Contract</u>
1.	F&L Coatings and Concrete, L.L.C.	Coating Structure	\$ 312,768.32	1.05%
2.	T&T Trucking	Dump Trucking	\$ 893,623.76	3.00%
3.	Champion Fuel Solutions	Petroleum/Fuel	\$ 506,386.80	1.70%
4.	Jimerson Underground, Inc.	Backfill Structures	<u>\$ 372,343.23</u>	<u>1.25%</u>
		TOTAL	\$2,085,122.11	7.00%

FISCAL NOTE: No significant Fiscal Operating impact is anticipated as a result of this project.

All known rights-of-way, easements, and/or right-of-entry required for the project have been acquired.

Randall V. Macchi, Chief Operating Officer
Houston Public Works

WBS No. R-000536-0034-4

Amount and Source of Funding:

\$33,740,000.00 from Fund No. 8500 – Water and Sewer System Consolidated Construction

Contact Information:

Name	Service Line	Contact Number
Roberto Medina, Interim Chief of Staff	Director`s Office - HPW Government Relations	(832) 395-2456
Maria Perez, HPW Agenda Director	Director`s Office - HPW Government Relations	(832) 395-2282
Markos E. Mengesha P.E., CCM, Assistant Director	Capital Projects	(832) 395-2365

ATTACHMENTS:

Description

Signed Coversheet
Maps

Type

Signed Cover sheet
Backup Material



CITY OF HOUSTON - CITY COUNCIL

Meeting Date:

District I

Item Creation Date: 7/5/2024

HPW – 20FAC2458 Contract Award / Pate Garver, LP

Agenda Item#:

Background:

SUBJECT: Contract Award for Easthaven Wastewater Treatment Plant (WWTP) Flow Diversion Package 1.

RECOMMENDATION: Award a Construction Contract to Pate Garver, LP for Easthaven Wastewater Treatment Plant (WWTP) Flow Diversion Package 1 and appropriate funds.

PROJECT NOTICE/JUSTIFICATION: This project is part of the City's Capital Improvement Plan (CIP) Consolidation Package for wastewater facilities and is required to control operations and maintenance cost and ensure regulatory compliance

-
The work to be performed under this contract award is necessary to maintain compliance with the Houston's wastewater consent decree with EPA and TCEQ.

DESCRIPTION/SCOPE: This project consists of the construction of 54-inch and 60-inch gravity sanitary sewer lines by microtunnel construction method, including the installation of valves, connections, and appurtenances. The Contract duration for this project is 620 calendar days. This project was designed by IDS Engineering Group.

LOCATION: The project area is generally bound by Almeda Genoa Road on the north, Beltway 8 on the south, Beamer Road on the east, and Monroe Road on the west.

-
BIDS: This project was advertised for bidding on 02/16/2024. Bids were received on 03/21/2024. The five (5) bids are as follows:

<u>Bidder</u>	<u>Bid Amount</u>
1. Pate Garver, LP	\$29,787,458.57
2. MC2 Civil, LLC	\$30,988,155.00
3. Boyer, Inc.	\$31,676,142.00
4. Reytec Construction	\$46,550,805.00
5. HB Trenchless, LLC	\$49,471,086.00

-
AWARD: It is recommended that this construction contract be awarded to Pate Garver, LP with a low bid of \$29,787,458.57 and that Addendum Number 1 be made a part of this Contract.

-
PROJECT COST: The total cost of this project is \$33,740,000.00 to be appropriated as follows:

· Bid Amount	\$29,787,458.57
· Contingencies	\$ 1,489,372.93
· Testing Services	\$ 225,000.00
· CIP Cost Recovery	\$ 1,489,734.10
· Construction Management	\$ 748,434.40

Testing Services will be provided by Terracon Consultants, Inc. under a previously approved contract.

Construction Management Services will be provided by Plummer Associates under a previously approved contract.

-
HIRE HOUSTON FIRST: The proposed contract requires compliance with the City's 'Hire Houston First' (HHF) ordinance that promotes economic opportunity for Houston business and supports job creation. In this case, Pate Garver, LP is a designated HHF company, but were the successful awardee without application of the HHF preference.

PAY OR PLAY PROGRAM: The proposed contract requires compliance with the City's 'Pay or Play' ordinance regarding health benefits for employees of City contractors. In this case, the Contractor provides health benefits to eligible employees in compliance with City policy.

M/WSBE PARTICIPATION: The contractor has submitted the following proposed program to satisfy the 13.00% MBE goal and 7.00% WBE goal for this project.

	<u>MBE - Name of Firms</u>	<u>Work Description</u>	<u>Amount</u>	<u>% of Contract</u>
1.	V&S Construction Company LLC	Installing Shafts	\$ 3,872,369.61	<u>13.00%</u>
	TOTAL		\$ 3,872,369.61	13.00%

	<u>WBE - Name of Firms</u>	<u>Work Description</u>	<u>Amount</u>	<u>% of Contract</u>
1.	F&L Coatings and Concrete, L.L.C.	Coating Structure	\$ 312,768.32	1.05%
2.	T&T Trucking	Dump Trucking	\$ 893,623.76	3.00%
3.	Champion Fuel Solutions	Petroleum/Fuel	\$ 506,386.80	1.70%
4.	Jimerson Underground, Inc.	Backfill Structures	<u>\$ 372,343.23</u>	<u>1.25%</u>
	TOTAL		\$2,085,122.11	7.00%

FISCAL NOTE: No significant Fiscal Operating impact is anticipated as a result of this project.

All known rights-of-way, easements, and/or right-of-entry required for the project have been acquired.

DocuSigned by:

 9/6/2024
BE463EF0DE454EB
 Randall V. Macchi, Chief Operating Officer
 Houston Public Works

WBS No. R-000536-0034-4

Amount and Source of Funding:

\$33,740,000.00 from Fund No. 8500 – Water and Sewer System Consolidated Construction

Contact Information:

Name	Service Line	Contact Number
Roberto Medina, Interim Chief of Staff	Director’s Office - HPW Government Relations	(832) 395-2456
Maria Perez, HPW Agenda Director	Director’s Office - HPW Government Relations	(832) 395-2282
Markos E. Mengesha P.E., CCM, Assistant Director	Capital Projects	(832) 395-2365

ATTACHMENTS:

Description	Type
Maps	Backup Material
SAP Documents	Financial Information
OBO Documents	Backup Material
Form B	Backup Material
Ownership Information Form & Tax Report	Backup Material
Pay or Play	Backup Material
Bid Tabulations	Backup Material
Bid Extension Letter	Backup Material
Form 1295	Backup Material

IDS Engineering Group \\houvgisdb1\Projects\00000057-083-00_EasthavenWWTP\diversion\Ex1_Southeast_WWTP_LocationMap_8.5x11.mxd Plotted: 5/15/2024 at 3:29:33 PM by PBond

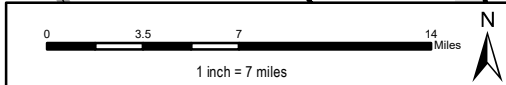
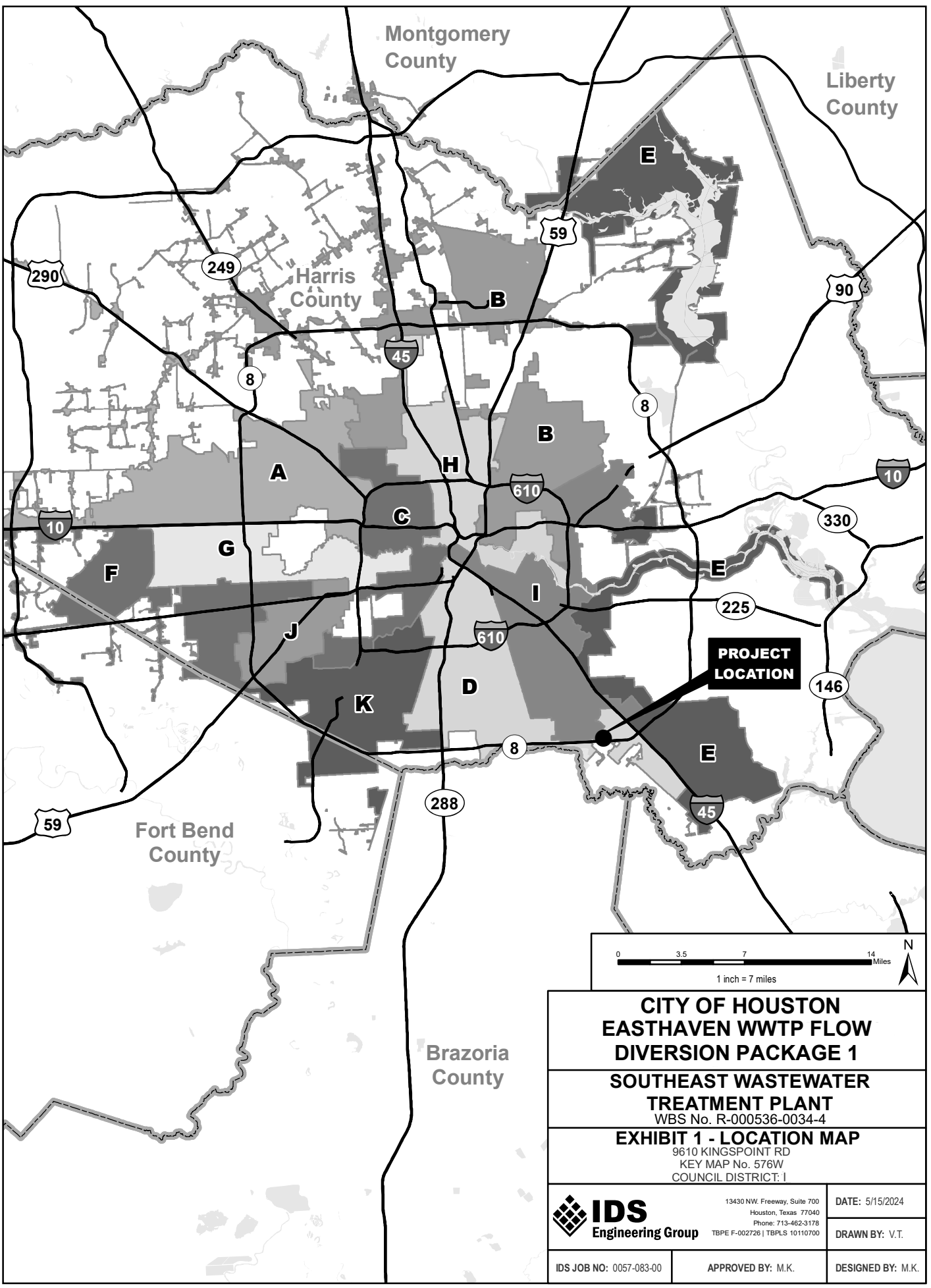

CITY OF HOUSTON EASTHAVEN WWTP FLOW DIVERSION PACKAGE 1		
SOUTHEAST WASTEWATER TREATMENT PLANT WBS No. R-000536-0034-4		
EXHIBIT 1 - LOCATION MAP 9610 KINGSPPOINT RD KEY MAP No. 576W COUNCIL DISTRICT: I		
 IDS Engineering Group	13430 NW. Freeway, Suite 700 Houston, Texas 77040 Phone: 713-462-3178 TBPE F-002726 TBPLS 10110700	DATE: 5/15/2024
IDS JOB NO: 0057-083-00	APPROVED BY: M.K.	DRAWN BY: V.T.
		DESIGNED BY: M.K.

IDS Engineering Group \\houvgisdb1\Projects\00000057-083-00_EasthavenWWTPDiverison\Ex1_FlowDiverisonPkg1_LocationMap_8.5x11.mxd Plotted: 6/18/2024 at 2:46:17 PM by PBond

COUNCIL DISTRICT I

EASTHAVEN WWTP FLOW DIVERSION PACKAGE 1 - SANITARY SEWER ROUTE

Harris County

Southeast Wastewater Treatment Plant

8

SAGEMEADOW UD

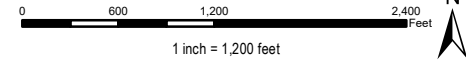

CITY OF HOUSTON EASTHAVEN WWTP FLOW DIVERSION PACKAGE 1

DIVERSION ROUTE ALIGNMENT
WBS No. R-000536-0034-4

EXHIBIT 1 - VICINITY MAP



IDS
Engineering Group

13430 NW. Freeway, Suite 700
Houston, Texas 77040
Phone: 713-462-3178
TBPE F-002726 | TBPLS 10110700

DATE: 6/18/2024

DRAWN BY: P.B.

IDS JOB NO: 0057-083-00

APPROVED BY: M.K.

DESIGNED BY: M.K.

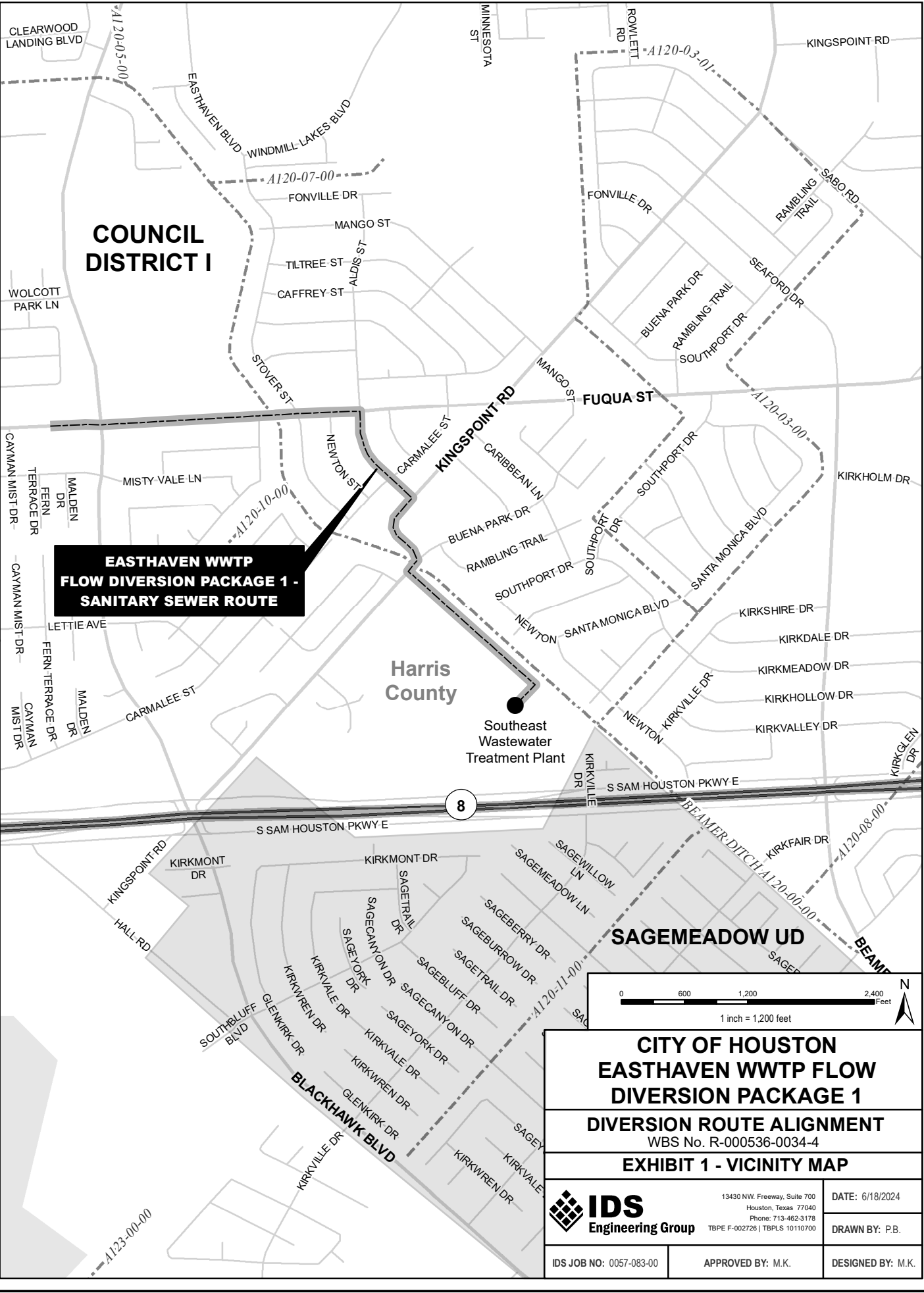



CITY OF HOUSTON - CITY COUNCIL

Meeting Date: 9/24/2024

ALL

Item Creation Date: 6/20/2024

HPW-20PMO133 / Contract Award / Traffic Systems Construction, Inc.

Agenda Item#: 40.

Summary:

ORDINANCE appropriating \$5,418,247.50 out of Dedicated Drainage and Street Renewal Capital Fund – Ad Valorem Tax; awarding contract to **TRAFFIC SYSTEMS CONSTRUCTION, INC** for Traffic Signal Work Order FY24 #1; setting a deadline for the bidder's execution of the contract and delivery of all bonds, insurance, and other required contract documents to the City; holding the bidder in default if it fails to meet the deadlines; providing funding for testing services and CIP Cost Recovery relating to construction of facilities financed by the Dedicated Drainage and Street Renewal Capital Fund – Ad Valorem Tax

Background:

SUBJECT: Contract Award for Traffic Signal Work Order FY24 #1.

RECOMMENDATION: (SUMMARY) Accept low bid, award construction contract to Traffic Systems Construction, Inc. for Traffic Signal Work Order FY24 #1 and appropriate funds.

PROJECT NOTICE/JUSTIFICATION: This project is part of the Transportation and Drainage Operations program, and is required to meet current City of Houston Standards as well as improve traffic signals, mobility, and safety at intersections.

DESCRIPTION/SCOPE: This contract consists of the removal of existing traffic signals and the installation of new traffic signals and other work to be detailed on the plans. The contract duration for this project is 365 calendar days.

LOCATION: The projects are located throughout the City of Houston (City).

BIDS: The project was advertised for bidding on March 29, 2024 and April 5, 2024. Bids were received on April 18, 2024. The two (2) bids are as follows:

	<u>Bidder</u>	<u>Bid Amounts</u>
1.	Traffic Systems Construction, Inc.	\$4,880,225.00
2.	Traf Tex	\$5,015,862.44

AWARD: It is recommended that this construction contract be awarded to Traffic Systems Construction, Inc. with a low bid of \$4,880,225.00.

PROJECT COST: The total cost of this project is \$5,418,247.50 to be appropriated as follows:

Bid Amount	\$4,880,225.00
Testing Services	\$50,000.00
CIP Cost Recovery	\$488,022.50

Testing Services will be provided by Earth Engineering, Inc., under a previously approved contract.

HIRE HOUSTON FIRST: The proposed contract requires compliance with the City's 'Hire Houston First' (HHF) ordinance that promotes economic opportunity for Houston businesses and supports job creation. In this case, Traffic Systems Construction, Inc., is a designated HHF company, but they were the successful awardee without application of the HHF preference.

PAY OR PLAY PROGRAM: The proposed contract requires compliance with the City's 'Pay or Play' ordinance regarding health benefits for employees of City contractors. In this case, the Contractor provides health benefits to eligible employees in compliance with City policy.

employees in compliance with City policy.

M/WSBE PARTICIPATION: The contractor has submitted the following proposed program to satisfy the 13% MBE goal and 7% WBE goal for this project.

	<u>MBE - Name of Firms</u>	<u>Work Description</u>	<u>Amount</u>	<u>% of Contract</u>
1.	H & N Contractor Management Services, LLC	Concrete Paving	\$851,599.26	17.45%
2.	Semper Striping, LLC	Highway Line Painting	\$198,625.16	4.07%
		TOTAL:	\$1,050,224.42	21.52%
	<u>WBE - Name of Firms</u>	<u>Work Description</u>	<u>Amount</u>	<u>% of Contract</u>
1.	CityLynx, Inc.	Traffic Signal Installation	\$341,615.75	7.00%
		CONTRACT TOTAL:	\$1,391,840.18	28.52%

FISCAL NOTE: No significant Fiscal Operating Impact is anticipated as a result of this project.

Randall V. Macchi
Chief Operating Officer
Houston Public Works

WBS No. N-321040-0117-4

Amount and Source of Funding:

\$5,418,247.50 - Fund No. 4046 -Dedicated Drainage and Street Renewal Capital Fund – Ad Valorem Tax

Contact Information:

Name	Service Line	Contact No.
Roberto Medina, Interim Chief of Staff	DO-HPW Government Relations	832.395.2456
Maria Perez, HPW Agenda Coordinator	DO-HPW Government Relations	832.395.2282
Michael Wahl, Assistant Director	TDO	832.395.2443

ATTACHMENTS:

Description	Type
Signed Coversheet	Signed Cover sheet
Map	Backup Material



CITY OF HOUSTON - CITY COUNCIL

Meeting Date:

ALL

Item Creation Date: 6/20/2024

HPW-20PMO133 / Contract Award / Traffic Systems Construction, Inc.

Agenda Item#:

Background:

SUBJECT: Contract Award for Traffic Signal Work Order FY24 #1.

RECOMMENDATION: (SUMMARY) Accept low bid, award construction contract to Traffic Systems Construction, Inc. for Traffic Signal Work Order FY24 #1 and appropriate funds.

PROJECT NOTICE/JUSTIFICATION: This project is part of the Transportation and Drainage Operations program, and is required to meet current City of Houston Standards as well as improve traffic signals, mobility, and safety at intersections.

DESCRIPTION/SCOPE: This contract consists of the removal of existing traffic signals and the installation of new traffic signals and other work to be detailed on the plans. The contract duration for this project is 365 calendar days.

LOCATION: The projects are located throughout the City of Houston (City).

BIDS: The project was advertised for bidding on March 29, 2024 and April 5, 2024. Bids were received on April 18, 2024. The two (2) bids are as follows:

	<u>Bidder</u>	<u>Bid Amounts</u>
1.	Traffic Systems Construction, Inc.	\$4,880,225.00
2.	Traf Tex	\$5,015,862.44

AWARD: It is recommended that this construction contract be awarded to Traffic Systems Construction, Inc. with a low bid of \$4,880,225.00.

PROJECT COST: The total cost of this project is \$5,418,247.50 to be appropriated as follows:

Bid Amount	\$4,880,225.00
Testing Services	\$50,000.00
CIP Cost Recovery	\$488,022.50

Testing Services will be provided by Earth Engineering, Inc., under a previously approved contract.

HIRE HOUSTON FIRST: The proposed contract requires compliance with the City's 'Hire Houston First' (HHF) ordinance that promotes economic opportunity for Houston businesses and supports job creation. In this case, Traffic Systems Construction, Inc., is a designated HHF company, but they were the successful awardee without application of the HHF preference.

PAY OR PLAY PROGRAM: The proposed contract requires compliance with the City's 'Pay or Play' ordinance regarding health benefits for employees of City contractors. In this case, the Contractor provides health benefits to eligible employees in compliance with City policy.

M/WSBE PARTICIPATION: The contractor has submitted the following proposed program to satisfy the 13% MBE goal and 7% WBE goal for this project.

	<u>MBE - Name of Firms</u>	<u>Work Description</u>	<u>Amount</u>	<u>% of Contract</u>
1.	H & N Contractor Management Services, LLC	Concrete Paving	\$851,599.26	17.45%
2.	Semper Striping, LLC	Highway Line Painting	\$198,625.16	4.07%
		TOTAL:	\$1,050,224.42	21.52%

1.	<u>WBE – Name of Firms</u>	<u>Work Description</u>	<u>Amount</u>	<u>% of Contract</u>
	CityLynx, Inc.	Traffic Signal Installation	\$341,615.75	7.00%
CONTRACT TOTAL:			\$1,391,840.18	28.52%

FISCAL NOTE: No significant Fiscal Operating Impact is anticipated as a result of this project.

DocuSigned by:

 9/6/2024
 BE463EF0DF454EB...

Randall V. Macchi
 Chief Operating Officer
 Houston Public Works

WBS No. N-321040-0117-4

Amount and Source of Funding:

\$5,418,247.50 - Fund No. 4046 -Dedicated Drainage and Street Renewal Capital Fund – Ad Valorem Tax

Contact Information:

Name	Service Line	Contact No.
Roberto Medina, Interim Chief of Staff	DO-HPW Government Relations	832.395.2456
Maria Perez, HPW Agenda Coordinator	DO-HPW Government Relations	832.395.2282
Michael Wahl, Assistant Director	TDO	832.395.2443

ATTACHMENTS:

Description	Type
SAP Documents	Financial Information
Map	Backup Material
Ownership Information Form and Tax Report	Backup Material
OBO Documents	Backup Material
Pay or Play (POP 1-3)	Backup Material
Form B	Backup Material
Form 1295	Backup Material
Bid Tabulation	Backup Material
Bid Extension Letter	Backup Material

Houston Public Works
Transportation & Drainage Operations

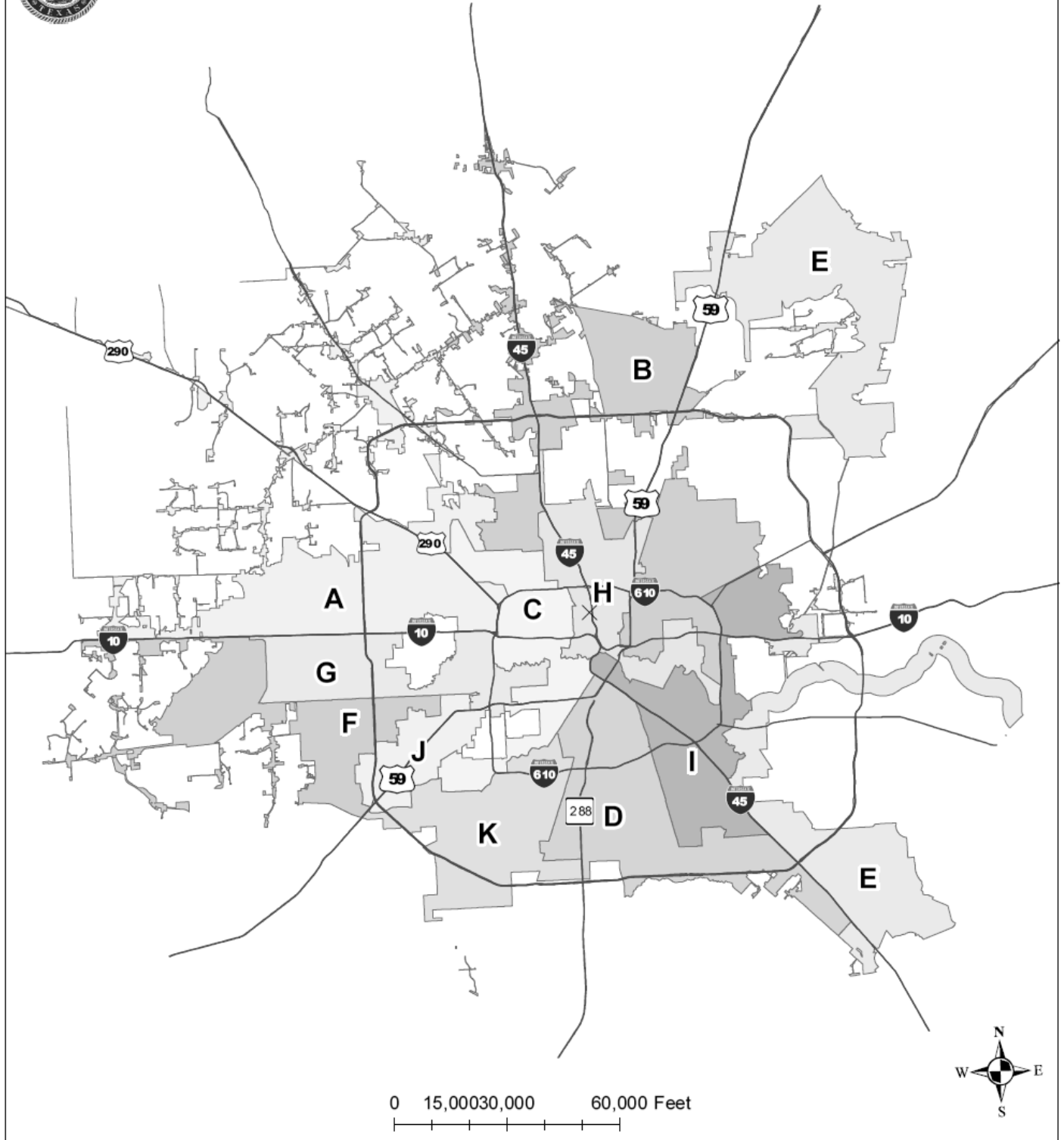

Traffic Signal Work Order FY24 #1

WBS No. N-321040-0117-4
Citywide

City Council District Map/Vicinity Map



CITY OF HOUSTON - CITY COUNCIL

Meeting Date: 9/24/2024

ALL

Item Creation Date: 8/28/2024

HHD – Environmental Protection Agency (EPA)

Agenda Item#: 41.

Summary:

ORDINANCE approving and authorizing Director of City of Houston Health Department to apply, accept, and expend Grant Award from **ENVIRONMENTAL PROTECTION AGENCY** for Environmental and Climate Justice Community Change Grants Program

TAGGED BY COUNCIL MEMBERS RAMIREZ and PLUMMER

This was Item 17 on Agenda of September 18, 2024

Background:

RECOMMENDATION:

The Director of the Houston Health Department (HHD) recommends City Council approve an ordinance authorizing the Director to apply, accept, and expend a grant award from the **Environmental Protection Agency (EPA)** for the Environmental and Climate Justice Community Change Grants Program. This Ordinance will cover the grant performance period from October 1, 2024 – September 30, 2027 with an anticipated award amount is \$20,000,000.00. HHD will not be required to provide a cash or in-kind match distribution.

SPECIFIC EXPLANATION:

HHD received notification from EPA of a funding opportunity soliciting projects that support community environmental improvements dealing with air quality, green space infrastructure, and community resilience hubs. HHD projects to use the funds as follows: personnel and fringe benefits – 5%, travel and training – 0.015%, equipment and supplies – 0.021%, contractual – 93%, (which include city departments, academics, private and local COB's) and indirect costs – 1%. This project will focus on the disadvantaged populations of the Greater Fifth Ward and Kashmere Gardens communities. This will encompass zip codes 77020 and 77026. HHD proposes to install a community solar energy system in the community along with nature-based infrastructure solutions, that will be supported by other activities to build resilience in the neighborhood.

This Community Change project titled "Vulnerable to Vibrant: Power for Change" seeks to address the lack of climate resiliency; detrimental pollution impacts; general environmental vulnerability; and the economic disadvantages prevalent throughout the community. The primary proposed activity is building a community solar energy system to support long-term resiliency ensuring that residents have consistent, clean energy especially during climate events (e.g., flooding, hurricanes, extreme heat or cold) and reduce emissions from traditional power sources, minimizing the carbon footprint of our community.

The next proposed project activity is to implement nature-based solutions providing ecosystem services. The nature-based solutions include constructing bioswales, and installing native grasses/trees, and vegetation to enhance phytoremediation (consistent with EPA guidance) to reduce pollution, flooding, heat, and contamination.

HHD also requests City Council authorize the Mayor to execute all related contracts, agreements, amendments, and documents with the approval as to form of the City Attorney in connection with the grant application and to authorize the Director or his designee to act as the City's representative with the authority to apply for, accept and expend the grant funds as awarded, and to accept and expend all subsequent supplemental awards, if any, and to extend the term and/or budget and project without further Council action for a period not to exceed 5 years.

Grant Source:

The funding for this project is from a federal government grant through the Environmental Protection Agency.

Fiscal Note:

No fiscal note is required on grant items.

Stephen L. Williams, M.Ed., MPA
Director - Houston Health Department

Amount and Source of Funding:

\$20,000,000.00
Federal Government Grant
Fund 5000

Contact Information:

Porfirio Villarreal; Health Department
832-393-5041

ATTACHMENTS:

Description

RCA Coversheet (Signed)

Type

Signed Cover sheet



CITY OF HOUSTON - CITY COUNCIL

Meeting Date: 9/10/2024

ALL

Item Creation Date: 8/28/2024

HHD – Environmental Protection Agency (EPA)

Agenda Item#: 57.

Summary:

Background:

RECOMMENDATION:

The Director of the Houston Health Department (HHD) recommends City Council approve an ordinance authorizing the Director to apply, accept, and expend a grant award from the **Environmental Protection Agency (EPA)** for the Environmental and Climate Justice Community Change Grants Program. This Ordinance will cover the grant performance period from October 1, 2024 – September 30, 2027 with an anticipated award amount is \$20,000,000.00. HHD will not be required to provide a cash or in-kind match distribution.

SPECIFIC EXPLANATION:

HHD received notification from EPA of a funding opportunity soliciting projects that support community environmental improvements dealing with air quality, green space infrastructure, and community resilience hubs. HHD projects to use the funds as follows: personnel and fringe benefits – 5%, travel and training – 0.015%, equipment and supplies – 0.021%, contractual – 93%, (which include city departments, academics, private and local COB's) and indirect costs – 1%. This project will focus on the disadvantaged populations of the Greater Fifth Ward and Kashmere Gardens communities. This will encompass zip codes 77020 and 77026. HHD proposes to install a community solar energy system in the community along with nature-based infrastructure solutions, that will be supported by other activities to build resilience in the neighborhood.

This Community Change project titled "Vulnerable to Vibrant: Power for Change" seeks to address the lack of climate resiliency; detrimental pollution impacts; general environmental vulnerability; and the economic disadvantages prevalent throughout the community. The primary proposed activity is building a community solar energy system to support long-term resiliency ensuring that residents have consistent, clean energy especially during climate events (e.g., flooding, hurricanes, extreme heat or cold) and reduce emissions from traditional power sources, minimizing the carbon footprint of our community.

The next proposed project activity is to implement nature-based solutions providing ecosystem services. The nature-based solutions include constructing bioswales, and installing native grasses/trees, and vegetation to enhance phytoremediation (consistent with EPA guidance) to reduce pollution, flooding, heat, and contamination.

HHD also requests City Council authorize the Mayor to execute all related contracts, agreements, amendments, and documents with the approval as to form of the City Attorney in connection with the grant application and to authorize the Director or his designee to act as the City's representative with the authority to apply for, accept and expend the grant funds as awarded, and to accept and expend all subsequent supplemental awards, if any, and to extend the term and/or budget and project without further Council action for a period not to exceed 5 years.

Grant Source:

The funding for this project is from a federal government grant through the Environmental Protection Agency.

Fiscal Note:

No fiscal note is required on grant items.

DocuSigned by:

Stephen Williams

Stephen L. Williams, M.Ed., MPA
Director - Houston Health Department

Amount and Source of Funding:

Total Funds: \$20,000,000.00

Fund 5000 - Federal Government

Contact Information:

Porfirio Villarreal; Health Department
832-393-5041

ATTACHMENTS:

Description

EPA Intent to Apply re Climate Control Project

Type

Contract/Exhibit



CITY OF HOUSTON - CITY COUNCIL

Meeting Date: 9/24/2024

ALL

Item Creation Date: 8/12/2024

HPW- 20PMO178 / Contract Award / Grava LLC

Agenda Item#: 42.

Summary:

ORDINANCE appropriating \$4,440,000.00 out of Water & Sewer System Consolidated Construction Fund; awarding contract to **GRAVA, LLC** for Westheimer Work Orders for Small Diameter Water Lines; setting a deadline for the bidder's execution of the contract and delivery of all bonds, insurance, and other required contract documents to the City; holding the bidder in default if it fails to meet the deadlines; providing funding for testing services, early completion bonus allowance, and CIP Cost Recovery relating to construction of facilities financed by the Water & Sewer System Consolidated Construction Fund

TAGGED BY COUNCIL MEMBERS KAMIN

This was Item 34 on Agenda of September 18, 2024

Background:

SUBJECT: Contract Award for Westheimer Work Orders for Small Diameter Water Lines.

RECOMMENDATION: (SUMMARY) Reject low bid, return bid bond, award Construction Contract to the second low bidder, Grava LLC for Westheimer Work Orders for Small Diameter Water Lines and appropriate funds.

PROJECT NOTICE/JUSTIFICATION: This project consists of the construction of small diameter waterline extensions at various locations throughout the City of Houston excluding the Central Business District. New small diameter water lines will be built in neighborhoods where the systems are inadequate. It will also provide for the replacement of old, deteriorated substandard, and under capacity small diameter water lines. Replacement and extensions of small diameter lines will be made when requested by Houston Water. Water quality will be improved by using new small diameter water lines and increasing the potable water circulation.

DESCRIPTION/SCOPE: This contract is for construction of small diameter waterline extensions at various locations throughout the City of Houston excluding the Central Business District. The Contract duration for this project is 365 calendar days. This is a work order based contract with work orders assigned on an as-needed basis.

LOCATION: The projects are located throughout the City of Houston.

BIDS: This project was advertised for bidding on June 28, 2024 and July 5, 2024. Bids were received on July 25, 2024. The five (5) bids are as follows:

Bidder

Bid Amounts

1.	T Construction LLC (non-compliance submission)	2.120 (Non-Responsive)
2.	Grava, LLC	3.250
3.	Texkota Enterprises, LLC	3.312
4.	Reliance Construction Services, LP	3.945
5.	MC2 Civil, LLC	4.575

AWARD: The apparent low bidder, T Construction LLC, was considered non-responsive due to not submitting an acceptable bid. Therefore, it is recommended that this construction contract be awarded to the second low bidder, Grava LLC, with a bid of \$4,000,000.00 (3.25 Adjustment Factor).

PROJECT COST: The total cost of this project is \$4,440,000.00 to be appropriated as follows:

• Bid Amount	\$4,000,000.00
• Early Completion Bonus Allowance	\$90,000.00
• Testing Services	\$150,000.00
• CIP Cost Recovery	\$200,000.00

Testing Services will be provided by ECS Southwest, LLP under a previously approved contract.

Bonus for early completion allowance is \$90,000.00. This represents the number of days between the contract substantial completion date and early completion date, 30 calendar days maximum, multiplied by \$1,000.00 per day for 3 approved locations. The actual amount, if applicable, will be based on the early completion date.

HIRE HOUSTON FIRST: The proposed contract requires compliance with the City's 'Hire Houston First' (HHF) ordinance that promotes economic opportunity for Houston business and supports job creation. In this case Grava LLC is a designated HHF company, but they were the successful awardee without application of the HHF preference.

PAY OR PLAY PROGRAM: The proposed contract requires compliance with the City's 'Pay or Play' ordinance regarding health benefits for employees of City contractors. In this case, the Contractor provides health benefits to eligible employees in compliance with City policy.

M/WSBE PARTICIPATION: The contractor has submitted the following proposed program to satisfy the 15.00% MBE goal, 8.00% WBE goal for this project.

	<u>MBE Name of Firms</u>	<u>Work Description</u>	<u>Amount</u>	<u>% of Contract</u>
1.	Grava LLC	Water and Sewer Line and Related Structures Construction	\$460,000.00	11.50%
2.	Texas Concrete Enterprise Ready Mix, Inc.	Ready Mix Concrete	\$70,000.00	1.75%
3.	Professional Traffic Control, LLC	Traffic Control Equipment	\$70,000.00	1.75%
		TOTAL	\$600,000.00	15.00%

	<u>WBE Name of Firms</u>	<u>Work Description</u>	<u>Amount</u>	<u>% of Contract</u>
1.	MVA Construction, LLC	Concrete Paving	\$80,000.00	2.00%
2.	Triton Supply, Inc.	Fixtures, Electric Lighting	\$80,000.00	2.00%
		TOTAL	\$160,000.00	4.00%

	<u>SBE Name of Firms</u>	<u>Work Description</u>	<u>Amount</u>	<u>% of Contract</u>
1.	Ceballos Construction, LLC	Concrete Paving	\$160,000.00	4.00%
		TOTAL	\$160,000.00	4.00%

CONTRACT TOTAL \$920,000.00 23.00%

FISCAL NOTE: No significant Fiscal Operating Impact is anticipated as a result of this project.

 Randall V. Macchi, Chief Operating Officer
 Houston Public Works

WBS No. S-000700-0089-4

Amount and Source of Funding:

\$4,440,000.00
 Water and Sewer System Consolidated Construction
 Fund No. 8500

Contact Information:

<u>Name</u>	<u>Service Line</u>	<u>Contact Number</u>
Roberto Medina, Interim Chief of Staff	DO-HPW Government Relations	832.395.2456
Maria Perez, HPW Agenda Coordinator	DO-HPW Government Relations	832.395.2282
Michael Wahl, Assistant Director	HPW-TDO	832.395.2443

ATTACHMENTS:

Description	Type
Map	Backup Material
Signed Coversheet	Signed Cover sheet

Houston Public Works
Transportation & Drainage Operations

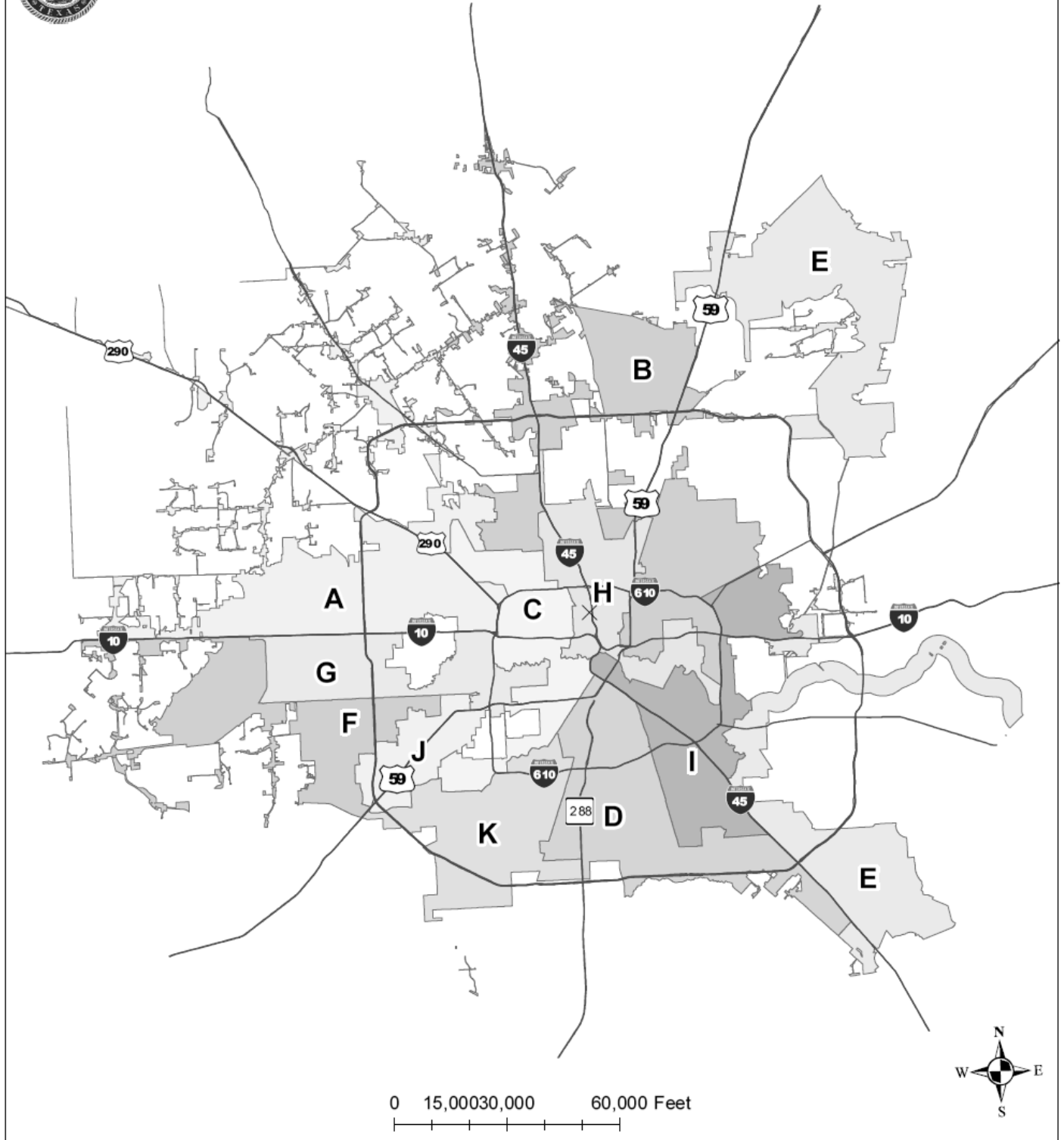

Westheimer Work
Orders for Small
Diameter Water Lines

WBS No. S-000700-0089-4
Citywide

City Council District Map/Vicinity Map



CITY OF HOUSTON - CITY COUNCIL

Meeting Date:

ALL

Item Creation Date: 8/12/2024

HPW- 20PMO178 / Contract Award / Grava LLC

Agenda Item#:

Background:

SUBJECT: Contract Award for Westheimer Work Orders for Small Diameter Water Lines.

RECOMMENDATION: (SUMMARY) Reject low bid, return bid bond, award Construction Contract to the second low bidder, Grava LLC for Westheimer Work Orders for Small Diameter Water Lines and appropriate funds.

PROJECT NOTICE/JUSTIFICATION: This project consists of the construction of small diameter waterline extensions at various locations throughout the City of Houston excluding the Central Business District. New small diameter water lines will be built in neighborhoods where the systems are inadequate. It will also provide for the replacement of old, deteriorated substandard, and under capacity small diameter water lines. Replacement and extensions of small diameter lines will be made when requested by Houston Water. Water quality will be improved by using new small diameter water lines and increasing the potable water circulation.

DESCRIPTION/SCOPE: This contract is for construction of small diameter waterline extensions at various locations throughout the City of Houston excluding the Central Business District. The Contract duration for this project is 365 calendar days. This is a work order based contract with work orders assigned on an as-needed basis.

LOCATION: The projects are located throughout the City of Houston.

BIDS: This project was advertised for bidding on June 28, 2024 and July 5, 2024. Bids were received on July 25, 2024. The five (5) bids are as follows:

Bidder	Bid Amounts
1. T Construction, LLC (non-compliance submission)	2.120 (Non-Responsive)
2. Grava, LLC	3.250
3. Texkota Enterprises, LLC	3.312
4. Reliance Construction Services, LP	3.945
5. MC2 Civil, LLC	4.575

AWARD: The apparent low bidder, T Construction LLC, was considered non-responsive due to not submitting an acceptable bid. Therefore, it is recommended that this construction contract be awarded to the second low bidder, Grava LLC, with a bid of \$4,000,000.00 (3.25 Adjustment Factor).

PROJECT COST: The total cost of this project is \$4,440,000.00 to be appropriated as follows:

• Bid Amount	\$4,000,000.00
• Early Completion Bonus Allowance	\$90,000.00
• Testing Services	\$150,000.00
• CIP Cost Recovery	\$200,000.00

Testing Services will be provided by ECS Southwest, LLP under a previously approved contract.

Bonus for early completion allowance is \$90,000.00. This represents the number of days between the contract substantial completion date and early completion date, 30 calendar days maximum, multiplied by \$1,000.00 per day for 3 approved locations. The actual amount, if applicable, will be based on the early completion date.

HIRE HOUSTON FIRST: The proposed contract requires compliance with the City's 'Hire Houston First' (HHF) ordinance that promotes economic opportunity for Houston business and supports job creation. In this case Grava LLC is a designated HHF company, but they were the successful awardee without application of the HHF preference.

PAY OR PLAY PROGRAM: The proposed contract requires compliance with the City's 'Pay or Play' ordinance regarding health benefits for employees of City contractors. In this case, the Contractor provides health benefits to eligible employees in compliance with City policy.

M/WSBE PARTICIPATION: The contractor has submitted the following proposed program to satisfy the 15.00% MBE goal, 8.00% WBE goal for this project.

	<u>MBE Name of Firms</u>	<u>Work Description</u>	<u>Amount</u>	<u>% of Contract</u>
1.	Grava LLC	Water and Sewer Line and Related Structures Construction	\$460,000.00	11.50%
2.	Texas Concrete Enterprise Ready Mix, Inc.	Ready Mix Concrete	\$70,000.00	1.75%
3.	Professional Traffic Control, LLC	Traffic Control Equipment	\$70,000.00	1.75%
	TOTAL		\$600,000.00	15.00%

	<u>WBE Name of Firms</u>	<u>Work Description</u>	<u>Amount</u>	<u>% of Contract</u>
1.	MVA Construction, LLC	Concrete Paving	\$80,000.00	2.00%
2.	Triton Supply, Inc.	Fixtures, Electric Lighting	\$80,000.00	2.00%
	TOTAL		\$160,000.00	4.00%

	<u>SBE Name of Firms</u>	<u>Work Description</u>	<u>Amount</u>	<u>% of Contract</u>
1.	Ceballos Construction, LLC	Concrete Paving	\$160,000.00	4.00%
	TOTAL		\$160,000.00	4.00%

CONTRACT TOTAL \$920,000.00 23.00%

FISCAL NOTE: No significant Fiscal Operating Impact is anticipated as a result of this project.

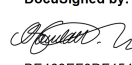
DocuSigned by:

 9/9/2024
 BE463EF0DF454EB...
 Randall V. Macchi, Chief Operating Officer
 Houston Public Works

WBS No. S-000700-0089-4

Amount and Source of Funding:

\$4,440,000.00 - Fund No. 8500 – Water and Sewer System Consolidated Construction

Contact Information:

<u>Name</u>	<u>Service Line</u>	<u>Contact Number</u>
Roberto Medina, Interim Chief of Staff	DO-HPW Government Relations	832.395.2456
Maria Perez, HPW Agenda Coordinator	DO-HPW Government Relations	832.395.2282
Michael Wahl, Assistant Director	HPW-TDO	832.395.2443

ATTACHMENTS:

Description	Type
SAP Documents	Financial Information
Map	Backup Material
Ownership Information Form and Tax Report	Backup Material
OBO Documents	Backup Material
Pay or Play (POP 1-3)	Backup Material
Form B	Backup Material
Form 1295	Backup Material
Bid Tabulation	Backup Material



CITY OF HOUSTON - CITY COUNCIL

Meeting Date: 9/24/2024

Item Creation Date:

Proposition A Council Member item - Sidewalk Ordinance

Agenda Item#: 43.

Summary:

PROPOSITION A COUNCIL MEMBER ITEM

ORDINANCE amending Sections 40-553 and 40-560 of the Code of Ordinances, Houston, Texas, relating to the required approval of a Sidewalk Plan or payment of a fee-in-lieu thereof for the construction of a new single-family residential use, other than a secondary dwelling unit

TAGGED BY COUNCIL MEMBER THOMAS

This was Item 36 on Agenda of September 18, 2024

ATTACHMENTS:

Description

Signed Prop A Council Member request

Type

Signed Cover sheet



CITY OF HOUSTON – CITY COUNCIL

Meeting Date: 8/27/24
Item Creation Date: 8/20/24

Chapter 40 Article XXII. – Sidewalks

Summary:

ORDINANCE amending **Sec. 40-553. – Applicability.** to remove item (3) as a requirement. Also, to amend **Sec. 40-560. Fee-in-lieu of sidewalk construction eligibility; fee established.** to remove item “a.” under subsection (b) as a requirement.

Background:

This amendment is regarding the “sidewalk to nowhere” issue that many residential developers are facing in the city of Houston. Currently, the city requires sidewalks to be constructed for new-build single-family homes, even if there are no other sidewalks on the street to connect the sidewalk to. Moreover, currently the city can waive the requirement to construct the sidewalk if the developer pays a fee. This amendment aims to remove the mandatory sidewalk construction requirement for new single-family residential developments, thereby eliminating both the construction requirement and the fee-in-lieu option.

Sec. 40-553. Applicability.

(a) Except as provided in subsection (b) of this section, any person or entity seeking approval for a building permit, certificate of occupancy, or other construction permit or approval required by this Code for any of the following activities must first obtain approval of a sidewalk plan in accordance with this article:

(3) Construction of a new single-family residential use other than a secondary dwelling unit;

Sec. 40-560. Fee-in-lieu of sidewalk construction eligibility; fee established.

(a) The planning official and sidewalk committee may waive the sidewalk construction requirement only in accordance with this section. An applicant must file a sidewalk plan with the department and pay the application fee for the plan review and fee-in-lieu determination.

(b) An applicant may request approval to pay a fee-in-lieu of sidewalk construction when either:

(1) The planning official determines the activity listed under section 40-553 meets the following conditions:

a. Construction of a new single-family residential use, other than a secondary dwelling unit;

Council Member Edward Pollard, District J

Council Member Carolyn Evans-Shabazz, District D

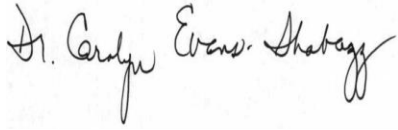
A handwritten signature in black ink that reads "Dr. Carolyn Evans-Shabazz". The signature is written in a cursive style with a large initial "D" and "C".

Council Member Tiffany Thomas, District F

A handwritten signature in black ink that reads "Tiffany Thomas". The signature is written in a cursive style with a large initial "T".