

# AGENDA

CITY OF HOUSTON • CITY COUNCIL  
November 8th, 2017

**MAYOR**  
SYLVESTER TURNER

**CONTROLLER**  
CHRIS B. BROWN

**DISTRICT COUNCIL MEMBERS**

Brenda Stardig  
District A

Steve Le  
District F

Jerry Davis  
District B

Greg Travis  
District G

Ellen R. Cohen  
District C

Karla Cisneros  
District H

Dwight A. Boykins  
District D

Robert Gallegos  
District I

Dave Martin  
District E

Mike Laster  
District J

Larry V. Green  
District K

**AT-LARGE COUNCIL MEMBERS**

Mike Knox  
Position 1

Michael Kubosh  
Position 3

David W. Robinson  
Position 2

Amanda K. Edwards  
Position 4

Jack Christie D.C.  
Position 5

Marta Crinejo Director - City Council Agenda

Anna Russell City Secretary

In accordance with the Texas Open Meetings Act the agenda is posted for public information, at all times, for at least 72 hours preceding the scheduled time of the meeting on the bulletin board located on the exterior wall of the City Hall building at 901 Bagby.

The agenda may be accessed via the Internet at

<http://houston.novusagenda.com/agendapublic/>. Copies of the agenda are available in the Office of the City Secretary in the City Hall Annex, Public Level at no charge. To receive the agenda by mail, send check or money order for \$52.00 for a one year subscription, made payable to the City of Houston to the attention of the City Secretary, P.O. Box 1562, Houston, Texas 77251.

To reserve time to appear before Council call 832-393-1100 or come to the Office of the City Secretary, City Hall Annex, Public Level at least 30 minutes prior to the scheduled public session shown on the agenda.

**NOTE: If a translator is required, please advise when reserving time to speak**

**AGENDA - COUNCIL MEETING Wednesday, November 8, 2017 - 9:00 AM**  
**City Hall - Second Floor - City Hall**

**INVOCATION AND PLEDGE OF ALLEGIANCE - Council Member Gallegos**

**9:00 AM - ROLL CALL**

**ADOPT MINUTES OF PREVIOUS MEETING**

**9:30 AM - PUBLIC SPEAKERS**

**PUBLIC SPEAKERS** - Pursuant to City Council Rule 8, City Council will hear from members of the public; the names and subject matters of persons who had requested to speak at the time of posting this Agenda are attached; the names and subject matters of persons who subsequently request to speak may be obtained in the City Secretary's Office.

**NOTE: If a translator is required, please advise when reserving time to speak**

**SP110817**

**HEARINGS - WEDNESDAY**

- 1 **9:00 A.M. - PUBLIC HEARING** on proposals for the City of Houston to enter into separate strategic partnership agreements or amended and restated strategic partnership agreements with the below named districts in Harris and Fort Bend Counties; on separate proposals by the City of Houston to annex for limited purposes certain territory within said districts; and on separate proposals by the City of Houston to annex for limited purposes certain territory in the vicinity of certain districts:
  1. **CYPRESS CREEK UTILITY DISTRICT**
  2. **HARRIS COUNTY MUNICIPAL UTILITY DISTRICT NO. 525**
  3. **HARRIS COUNTY IMPROVEMENT DISTRICT NO. 17**
  4. **HARRIS COUNTY MUNICIPAL UTILITY DISTRICT NO. 191**
  5. **HARRIS COUNTY MUNICIPAL UTILITY DISTRICT NO. 278**
  6. **HARRIS-FORT BEND COUNTIES MUNICIPAL UTILITY DISTRICT NO. 5**

**MAYOR'S REPORT**

**CONSENT AGENDA NUMBERS 2 through 25**

**MISCELLANEOUS - NUMBER 2**

2. **RECOMMENDATION** from Acting Director Department of Public Works & Engineering for approval of extended unpaid leave of absence for **JULIUS TATUM, Equipment Worker**, beginning February 27, 2016 and continuing until July 24, 2017

### **ACCEPT WORK - NUMBER 3 through 5**

3. RECOMMENDATION from Acting Director Department of Public Works & Engineering, for approval of final contract amount of \$3,936,082.74 and acceptance of work on contract with **PORTLAND UTILITIES CONSTRUCTION COMPANY, LLC** for Sanitary Sewer Rehabilitation by Sliplining and Pipe Bursting Methods, (4257-131) - 2.57% over the original contract amount - Enterprise Fund **DISTRICTS A - STARDIG; B - DAVIS; D - BOYKINS; H - CISNEROS; J - LASTER and K - GREEN**
4. RECOMMENDATION from Acting Director Department of Public Works & Engineering, for approval of final contract amount of \$14,578,329.69 and acceptance of work on contract with **REYTEC CONSTRUCTION RESOURCES, INC** for Neighborhood Street Reconstruction Project 465 - 4.70% under the original contract amount - **DISTRICT A - STARDIG**
5. RECOMMENDATION from Acting Director Department of Public Works & Engineering, for approval of final contract amount of \$5,724,203.67 and acceptance of work on contract with **SER CONSTRUCTION PARTNERS, LLC** for Silber Paving & Drainage from IH 10 to Hartland 2.90% under the original contract amount - **DISTRICT A - STARDIG**

### **PURCHASING AND TABULATION OF BIDS - NUMBER 6**

6. **DIGITAL SANDBOX, INC** for purchase of Software Enhancements and Support Services for the Digital Sandbox System from the General Services Administration Schedule 70 Contract through the Cooperative Purchasing Program for the Mayor's Office of Public Safety and Homeland Security - \$193,000.00 - Grant Fund

### **ORDINANCES - NUMBERS 7 through 25**

7. ORDINANCE authorizing one or more series of City of Houston, Texas Public Improvement Refunding Bonds as may be further designated, described and provided herein; authorizing the payment and security thereof and certain designated officials to approve the principal amount, interest rates, prices, terms and sale thereof in accordance with the parameters described herein; authorizing such officials to determine the outstanding obligations to be refunded and/or defeased; approving certain other procedures, provisions and agreements related thereto, including authorizing the execution and delivery of one or more purchase contracts, Paying Agent/Registrar Agreements, Escrow Agreements, and other agreements; approving the preparation, distribution and use of a Preliminary Official Statement and Official Statement in connection with such offering; authorizing the engagement of Bond Counsel and Special Disclosure Counsel; making certain findings and other declarations necessary and incidental to the issuance of such refunding bonds; and declaring an emergency
8. ORDINANCE pursuant to and implementing the provisions of Ordinance No. 2017-168, approving and authorizing the City to borrow from the United States Department of Housing and Urban Development ("HUD") \$5,062,000.00 of loan funds provided under Section 108 of the Housing and Community Development Act of 1974 ("Section 108"); appropriating \$5,062,000.00 of Section 108 Funds and allocating \$8,800,000.00 of Economic Development Initiative Grant Funds to fund the purchase of approximately 9.177 acres of land out of the G.P. Foster Survey, Abstract No. 273, Harris County, Texas, for a purchase price of \$13,850,000.00 and related closing costs of \$12,000.00; approving and authorizing a contract for loan guarantee assistance, a promissory note, and related documents between the City of Houston and HUD relating to the loan of the Section 108 Funds - **DISTRICT D - BOYKINS**
9. ORDINANCE finding and determining that public convenience and necessity no longer require the continued use of Felix Street, from Harrisburg Street south to its terminus, located within the Harrisburg Market Subdivision out of the S.M. Williams Survey, A-87; vacating and abandoning the street easement to **BakerRipley and Harrisburg Blue Willow, Ltd.**, the abutting owners, in consideration of their payment to the City of \$245,959.00, and other consideration - **DISTRICT H - CISNEROS**

10. ORDINANCE authorizing the sale of a 30-foot-wide subsurface pipeline easement traversing the City of Houston Southeast Water Purification Plant, located in the W.C. R.R. Co. Survey, Abstract No. 933, the William H. Anthony Survey, Abstract No. 1460, and the Day Land & Cattle Survey, Abstract No. 1042, Harris County, Texas, to Seabrook Pipeline, LLC, in consideration of its payment to the City of \$56,493.00 and other consideration - **DISTRICT E - MARTIN**
11. ORDINANCE relating to the Fiscal Affairs of the **EAST DOWNTOWN REDEVELOPMENT AUTHORITY** on behalf of **REINVESTMENT ZONE NUMBER FIFTEEN, CITY OF HOUSTON, TEXAS (EAST DOWNTOWN ZONE)**; approving the Fiscal Year 2018 Operating Budget for the Authority and the Fiscal Years 2018-2022 Capital Improvements Budget for the Zone - **DISTRICT I - GALLEGOS**
12. ORDINANCE establishing the north side of the **1400 block of Lombardy Street**, within the City of Houston, Texas, as a special minimum lot size block pursuant to Chapter 42 of the Code of Ordinances, Houston, Texas - **DISTRICT I - GALLEGOS**
13. ORDINANCE establishing the east side of the **1700-1800 block of Lombardy Street**, within the City of Houston, Texas, as a special minimum lot size block pursuant to Chapter 42 of the Code of Ordinances, Houston, Texas - **DISTRICT I - GALLEGOS**
14. ORDINANCE establishing the north and south sides of the **2200 block of McClendon Street**, within the City of Houston, Texas, as a special minimum lot size block pursuant to Chapter 42 of the Code of Ordinances, Houston, Texas - **DISTRICT C - COHEN**
15. ORDINANCE establishing certain areas known as **North MacGregor Oaks Subdivision and Timber Crest Subdivision**, within the City of Houston, as special minimum lot size areas pursuant to Chapter 42 of the Code of Ordinances, Houston, Texas - **DISTRICT D - BOYKINS**
16. ORDINANCE establishing the east and west sides of the **5200 block of Sue Marie Lane**, within the City of Houston, Texas, as a special minimum lot size block pursuant to Chapter 42 of the Code of Ordinances, Houston, Texas - **DISTRICT B - DAVIS**
17. ORDINANCE approving payment of \$11,432.38 to **TIMES CONSTRUCTION, INC** under contract with the City for Concrete Channel at 10418 Raymondville Road at Charles Street authorized by Ordinance No. 2015-0624 - **DISTRICT B - DAVIS**
18. ORDINANCE appropriating \$443,000.00 out of Fire Consolidated Construction Fund; \$748,000.00 out of Parks Consolidated Construction Fund; \$135,000.00 out of Solid Waste Consolidated Construction Fund; \$653,000.00 out of Police Consolidated Construction Fund; \$352,000.00 out of Public Library Consolidated Construction Fund; \$266,000.00 out of Public Health Consolidated Construction Fund; and \$623,000.00 out of General Improvement Consolidated Construction fund for reimbursement project management costs for FY18 Capital Improvement Plan (CIP) Projects for City departments
19. ORDINANCE appropriating \$600,000.00 out of Street and Traffic Control and Storm Drainage DDSRF as an additional appropriation; approving and authorizing first amendment to Professional Engineering Services Contract between the City of Houston and **JONES & CARTER, INC** for FY16 Mitigation Program for Capital Improvement Projects (Approved by Ordinance No. 2016-0095); providing funding for CIP Cost Recovery relating to construction of facilities financed by the Street & Traffic Control and Storm Drainage DDSRF
20. ORDINANCE finding and determining public convenience and necessity for the acquisition of easements through dedication, purchase or condemnation, in connection with the public improvement project known as the 108-inch water line from Imperial Valley Drive to Green Plaza Drive Project; authorizing the payment of costs for parcel purchases/condemnations, relocation assistance expenses, appraisal fees, title policies/ services, recording fees, court costs, expert witness fees and other acquisition costs in connection with the project, located in the William Sevey Survey, A-699 and the Simon Contreras Survey, A-220, Houston, Harris County, Texas **DISTRICT B - DAVIS**
21. ORDINANCE finding and determining public convenience and necessity for the acquisition of

real property interests through dedication, purchase or condemnation, in connection with the public improvement project known as Shepherd and Durham Paving and Drainage (from Washington Avenue to Dickson Street) Project; authorizing the acquisition of fee simple title interest in or easement purchase and the use of eminent domain and authorizing the payment of costs for parcel purchases/condemnations, relocation assistance expenses, appraisal fees, title policies/ services, recording fees, court costs, expert witness fees and other acquisition costs in connection with the project, located in the John Austin Survey, A-1, Houston, Harris County, Texas **DISTRICT C - COHEN**

22. ORDINANCE appropriating \$2,760,878.00 out of Water & Sewer System Consolidated Construction Fund; awarding contract to **PORTLAND UTILITIES CONSTRUCTION COMPANY, LLC** for Wastewater Collection System Rehabilitation and Renewal; setting a deadline for the bidder's execution of the contract and delivery of all bonds, insurance, and other required contract documents to the City; holding the bidder in default if it fails to meet the deadlines; providing funding for the engineering and testing, and contingencies relating to the construction of facilities financed by the Water & Sewer System Consolidated Construction Fund (WW4235-102)
23. ORDINANCE appropriating \$3,222,181.00 out of Metro Projects Construction DDSRF, awarding contract to **PRECISE SERVICES, INC** for Roadway Pavement Replacement Project: Martinville Drive and Sunbeam Street; setting a deadline for the bidder's execution of the contract and delivery of all bonds, insurance, and other required contract documents to the City; holding the bidder in default if it fails to meet the deadlines; providing funding for testing services, CIP Cost Recovery, and contingencies relating to construction of facilities financed by the Metro Projects Construction DDSRF - **DISTRICTS D - BOYKINS and E - MARTIN**
24. ORDINANCE appropriating \$6,350,000.00 out of Street & Traffic Control and Storm Drainage DDSRF awarding contract to **SER CONSTRUCTION PARTNERS, LLC.** for Yorkshire Area Drainage and Paving Improvements; setting a deadline for the bidder's execution of the contract and delivery of all bonds, insurance, and other required contract documents to the City; holding the bidder in default if it fails to meet the deadlines; providing funding for Testing, CIP Cost Recovery, Construction Management, and Contingencies relating to construction of facilities financed by the Street & Traffic Control and Storm Drainage DDSRF - **DISTRICT G - TRAVIS**
25. ORDINANCE No. 2017-851 passed first reading November 1, 2017  
ORDINANCE granting to **ABRACADABRA SEPTIC PUMPING, LP, a Texas Limited Partnership**, the right, privilege, and franchise to collect, haul and transport solid waste and industrial waste from commercial properties located within the City of Houston, Texas, pursuant to Chapter 39, Code of Ordinances, Houston, Texas; providing for related terms and conditions; and making certain findings related thereto - **SECOND READING**

#### **END OF CONSENT AGENDA**

#### **CONSIDERATION OF MATTERS REMOVED FROM CONSENT AGENDA**

#### **MATTERS HELD - NUMBERS 26 and 27**

26. RECOMMENDATION from Acting Director Department of Public Works & Engineering for approval of final contract amount of \$1,577,278.62 and acceptance of work on contract with **CES UTILITIES, INC** for Fire Hydrant Replacement Project - 8.37% under the original contract amount (WA11180) - **DISTRICTS A - STARDIG; B - DAVIS; C - COHEN; D - BOYKINS; E- MARTIN; F - LE; G - TRAVIS; I - GALLEGOS; J - LASTER and K - GREEN**  
**TAGGED BY COUNCIL MEMBER GREEN**  
This was Item 4 on Agenda of November 1, 2017
27. MOTION by Council Member Cohen/Seconded by Council Member Knox to adopt recommendation from Chief Procurement Officer, to award to **RUSH TRUCK CENTERS OF TEXAS, LP** for Cummins replacement parts and repair services for the Fleet

Management Department - 3 Years with two one-year options - \$6,388,814.00 -  
Fleet Management Fund

**TAGGED BY COUNCIL MEMBERS GREEN and BOYKINS**

This was Item 5 on Agenda of November 1, 2017

**MATTERS TO BE PRESENTED BY COUNCIL MEMBERS - Council Member Christie first**

**ALL ORDINANCES ARE TO BE CONSIDERED ON AN EMERGENCY BASIS AND TO  
BE PASSED ON ONE READING UNLESS OTHERWISE NOTED, ARTICLE VII,  
SECTION 7, CITY CHARTER**

**NOTE** - WHENEVER ANY AGENDA ITEM, WHETHER OR NOT ON THE CONSENT AGENDA, IS NOT READY FOR COUNCIL ACTION AT THE TIME IT IS REACHED ON THE AGENDA, THAT ITEM SHALL BE PLACED AT THE END OF THE AGENDA FOR ACTION BY COUNCIL WHEN ALL OTHER AGENDA ITEMS HAVE BEEN CONSIDERED.

CITY COUNCIL RESERVES THE RIGHT TO TAKE UP AGENDA ITEMS OUT OF THE ORDER IN WHICH THEY ARE POSITIONED IN THIS AGENDA. ALSO, AN ITEM THAT HAS BEEN TAGGED UNDER CITY COUNCIL RULE (HOUSTON CITY CODE 2-2) OR DELAYED TO ANOTHER DAY MAY BE NEVERTHELESS CONSIDERED LATER AT THE SAME CITY COUNCIL MEETING.



## **CITY OF HOUSTON - CITY COUNCIL**

Meeting Date: 11/8/2017

Item Creation Date:

SP110817

Agenda Item#:



## CITY OF HOUSTON - CITY COUNCIL

Meeting Date: 11/8/2017

District A, District B, District E, District F, ETJ

Item Creation Date: 9/7/2017

PLN - SPA Fall 2017 - Ordinance Calling Public Hearings

Agenda Item#: 1

### **Summary:**

**9:00 A.M. - PUBLIC HEARING** on proposals for the City of Houston to enter into separate strategic partnership agreements or amended and restated strategic partnership agreements with the below named districts in Harris and Fort Bend Counties; on separate proposals by the City of Houston to annex for limited purposes certain territory within said districts; and on separate proposals by the City of Houston to annex for limited purposes certain territory in the vicinity of certain districts:

1. **CYPRESS CREEK UTILITY DISTRICT**
2. **HARRIS COUNTY MUNICIPAL UTILITY DISTRICT NO. 525**
3. **HARRIS COUNTY IMPROVEMENT DISTRICT NO. 17**
4. **HARRIS COUNTY MUNICIPAL UTILITY DISTRICT NO. 191**
5. **HARRIS COUNTY MUNICIPAL UTILITY DISTRICT NO. 278**
6. **HARRIS-FORT BEND COUNTIES MUNICIPAL UTILITY DISTRICT NO. 5**

### **Background:**

Since 2000, the City of Houston has conducted limited purpose annexations through Strategic Partnership Agreements (SPA) with utility districts. Such agreements allow the City to annex all or part of a utility district for limited purposes. The City can then levy a sales tax and provide specified, limited services to the area. Typically, the City rebates 50% of the sales tax collections back to the utility district. State law prevents a city from levying a property tax in areas annexed for limited purposes.

Prior to entering into these agreements, the City is required to hold two public hearings in accordance with Section 43.075 of the Texas Local Government Code, which states:

*Before the governing body of a municipality or a district adopts a Strategic Partnership Agreement, it shall conduct two public hearings at which members of the public who wish to present testimony or evidence regarding the proposed agreement shall be given the opportunity to do so.*

The hearings called by this ordinance are for agreements, or amendments to existing agreements, with the following Utility Districts:

#### **New Agreements:**

Cypress Creek UD

Harris County Improvement District 17

Harris County MUD 525

#### **Amendments to existing Agreements:**

Fort Bend County MUD 30 (Amendment 3)  
Harris Fort Bend Counties MUD 5 (Amendment 2)  
Harris County MUD 191 (Amendment 4)  
Harris County MUD 278 (Amendment 1)

Each of these new agreements or amendments will add commercial property and undeveloped land intended for commercial use to the SPA. In addition, the City will levy a 1% sales tax and the taxes collected will be divided evenly between the City and the District.

To date, the City of Houston has executed these agreements with 237 utility districts. In 2017, these agreements resulted in a net income to the City of Houston of approximately \$53.3 million. They have resulted in a similar amount going to the community through the rebates.

The Planning and Development Department's recommendation is to have the public hearings on November 1, 2017 and November 7, 2017 in City Council chambers. The recommended date for passing the SPA and the limited purpose annexation Ordinances is November 29, 2017, before the effective date of the State Legislature's changes to the annexation laws on December 1, 2017. This timeline must be met in order for the annexations to be effective before Senate Bill 6 from the special session for the 85<sup>th</sup> legislature goes into effect on December 1, 2017. Once that bill is enacted, the City's ability to conduct limited purpose annexations through Strategic Partnership Agreements will be significantly curtailed.

---

Patrick Walsh, P.E.  
Director  
Planning and Development Department

### **Contact Information:**

Rupesh Koshy  
Phone: 832-393-6552

### **ATTACHMENTS:**

<b>Description</b>	<b>Type</b>
cover sheet	Signed Cover sheet
SPA Location Map	Backup Material



**CITY OF HOUSTON - CITY COUNCIL**

Meeting Date:

District A, District B, District E, District F, ETJ

Item Creation Date: 9/7/2017

PLN - SPA Fall 2017 - Ordinance Calling Public Hearings

Agenda Item#:

**Background:**

Since 2000, the City of Houston has conducted limited purpose annexations through Strategic Partnership Agreements (SPA) with utility districts. Such agreements allow the City to annex all or part of a utility district for limited purposes. The City can then levy a sales tax and provide specified, limited services to the area. Typically, the City rebates 50% of the sales tax collections back to the utility district. State law prevents a city from levying a property tax in areas annexed for limited purposes.

Prior to entering into these agreements, the City is required to hold two public hearings in accordance with Section 43.075 of the Texas Local Government Code, which states:

*Before the governing body of a municipality or a district adopts a Strategic Partnership Agreement, it shall conduct two public hearings at which members of the public who wish to present testimony or evidence regarding the proposed agreement shall be given the opportunity to do so.*

The hearings called by this ordinance are for agreements, or amendments to existing agreements, with the following Utility Districts:

**New Agreements:**

- Cypress Creek UD
- Harris County Improvement District 17
- Harris County MUD 525

**Amendments to existing Agreements:**

- Fort Bend County MUD 30 (Amendment 3)
- Harris Fort Bend Counties MUD 5 (Amendment 2)
- Harris County MUD 191 (Amendment 4)
- Harris County MUD 278 (Amendment 1)

Each of these new agreements or amendments will add commercial property and undeveloped land intended for commercial use to the SPA. In addition, the City will levy a 1% sales tax and the taxes collected will be divided evenly between the City and the District.

To date, the City of Houston has executed these agreements with 237 utility districts. In 2017, these agreements resulted in a net income to the City of Houston of approximately \$53.3 million. They have resulted in a similar amount going to the community through the rebates.

The Planning and Development Department's recommendation is to have the public hearings on November 1, 2017 and November 7, 2017 in City Council chambers. The recommended date for passing the SPA and the limited purpose annexation Ordinances is November 29, 2017, before the effective date of the State Legislature's changes to the annexation laws on December 1, 2017.

This timeline must be met in order for the annexations to be effective before Senate Bill 6 from the special session for the 85<sup>th</sup> legislature goes into effect on December 1, 2017. Once that bill is enacted, the City's ability to conduct limited purpose annexations through Strategic Partnership Agreements will be significantly curtailed.

Patrick Walsh, P.E.  
Director  
Planning and Development Department

**Contact Information:**

Rupesh Koshy  
Phone: 832-393-6552

**ATTACHMENTS:**

Description	Type
SPA Location Map	Backup Material

# Strategic Partnership Agreement : November 2017

- New SPA Locations
- Major Highways
- Major Streets
- A
- B
- C
- D
- E
- F
- G
- H
- I
- J
- K

Source: City of Houston GIS Database  
Date: September 6, 2017

This map is made available for reference purposes only and should not be substituted for a survey product. The City of Houston will not accept liability of any kind in conjunction with its use.



**PLANNING & DEVELOPMENT DEPARTMENT**

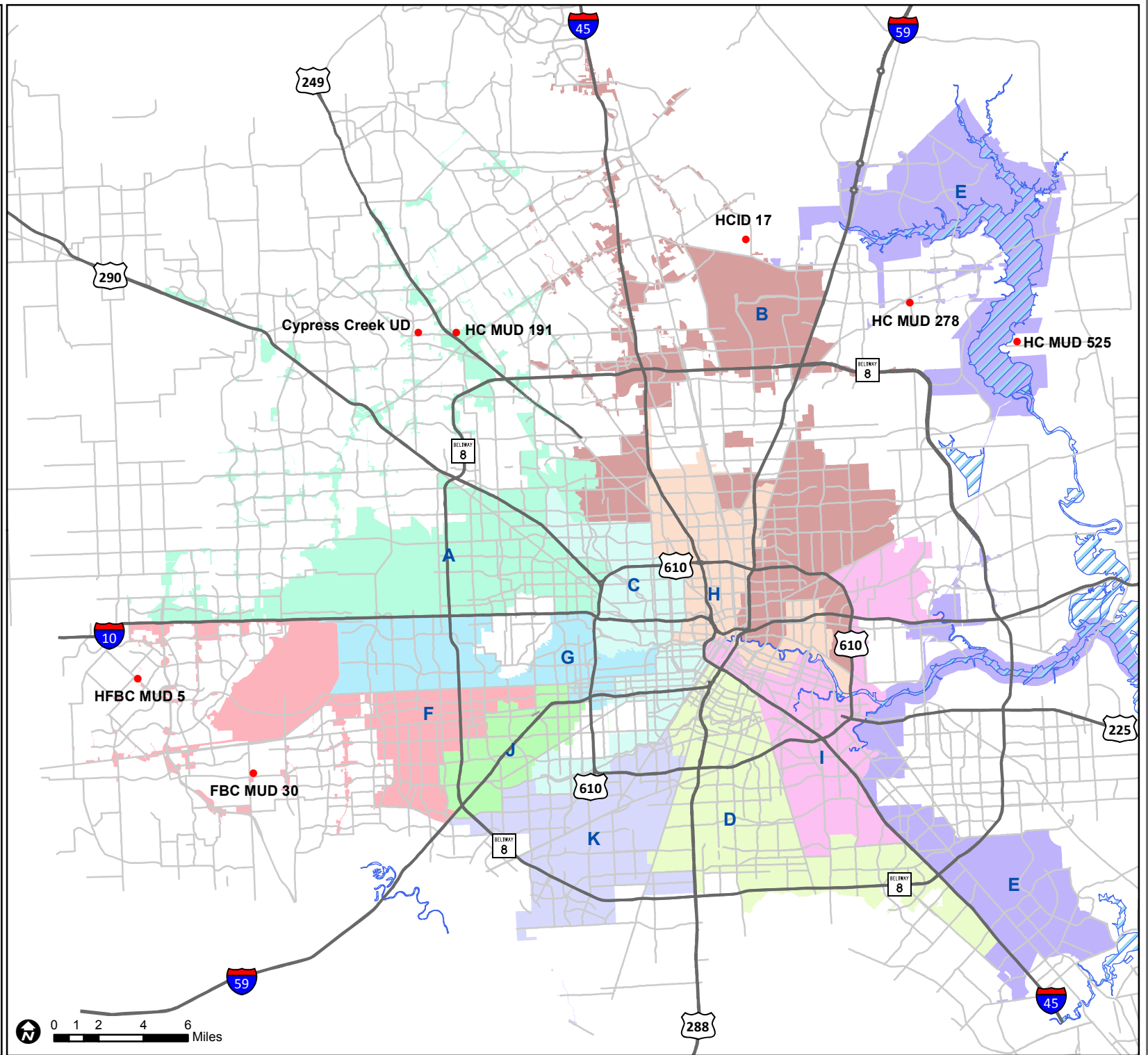



## CITY OF HOUSTON - CITY COUNCIL

Meeting Date: 11/8/2017

ALL

Item Creation Date: 10/5/2017

20JM02 Motion to Extend Unpaid Leave of Absence for  
Julius Tatum, Equipment Worker #155499

Agenda Item#: 2.

### **Summary:**

RECOMMENDATION from Acting Director Department of Public Works & Engineering for approval of extended unpaid leave of absence for **JULIUS TATUM, Equipment Worker**, beginning February 27, 2016 and continuing until July 24, 2017

### **Background:**

**RECOMMENDATION:** Approve the motion to extend unpaid leave of absence for Julius Tatum, Equipment Worker.

**SPECIFIC EXPLANATION:** The Department of Public Works & Engineering requests City Council to approve a motion to extend the unpaid leave of absence for Julius Tatum, Equipment Worker, Employee #155499, beginning February 27, 2016 and continuing until July 24, 2017.

Mr. Tatum has a medical condition that has prevented his return to duty since August 31, 2015. On May 16, 2017, the department recommended that Mr. Tatum be medically separated. Mr. Tatum requested no accommodation or job search be initiated. Mr. Tatum has been approved by the Municipal Civil Service Commission for two 90-day unpaid leaves of absence from August 31, 2015 through November 28, 2015 and November 29, 2015 through February 26, 2016.

In accordance with Code of Ordinances 14-172, any further unpaid leaves of absence must be approved by the City Council. Therefore, the department requests that City Council approve an extended unpaid leave of absence from February 27, 2016 through July 24, 2017. The Civil Service Commission approved a medical separation for Mr. Tatum effective July 25, 2017.

---

Carol Ellinger Haddock, P.E.  
Acting Director  
Department of Public Works and Engineering

**Contact Information:**

Janet McCown  
832-395-2752

**ATTACHMENTS:**

**Description**

Signed Coversheet

**Type**

Signed Cover sheet



**CITY OF HOUSTON - CITY COUNCIL**

Meeting Date:

ALL

Item Creation Date: 10/5/2017

20JM02 Motion to Extend Unpaid Leave of Absence for Julius Tatum, Equipment Worker  
#155499

Agenda Item#:

**Summary:**

Motion to Extend Unpaid Leave of Absence for Julius Tatum, Equipment Worker #155499

**Background:**

**RECOMMENDATION:** Approve the motion to extend unpaid leave of absence for Julius Tatum, Equipment Worker.

**SPECIFIC EXPLANATION:** The Department of Public Works & Engineering requests City Council to approve a motion to extend the unpaid leave of absence for Julius Tatum, Equipment Worker, Employee #155499, beginning February 27, 2016 and continuing until July 24, 2017.

Mr. Tatum has a medical condition that has prevented his return to duty since August 31, 2015. On May 16, 2017, the department recommended that Mr. Tatum be medically separated. Mr. Tatum requested no accommodation or job search be initiated. Mr. Tatum has been approved by the Municipal Civil Service Commission for two 90-day unpaid leaves of absence from August 31, 2015 through November 28, 2015 and November 29, 2015 through February 26, 2016.

In accordance with Code of Ordinances 14-172, any further unpaid leaves of absence must be approved by the City Council. Therefore, the department requests that City Council approve an extended unpaid leave of absence from February 27, 2016 through July 24, 2017. The Civil Service Commission approved a medical separation for Mr. Tatum effective July 25, 2017.

Carol Ellinger Haddock, P.E.

Acting Director

Department of Public Works and Engineering

**Contact Information:**

Janet McCown  
832-395-2752

**ATTACHMENTS:**

**Description**

Civil Service Letter and Final Order of Commission

**Type**

Backup Material



## CITY OF HOUSTON - CITY COUNCIL

Meeting Date: 11/8/2017

District A, District B, District D, District H, District J, District K

Item Creation Date: 9/21/2017

20WWO717 Accept Work/Portland Utilities Construction Company, LLC

Agenda Item#: 3.

### **Summary:**

RECOMMENDATION from Acting Director Department of Public Works & Engineering, for approval of final contract amount of \$3,936,082.74 and acceptance of work on contract with **PORTLAND UTILITIES CONSTRUCTION COMPANY, LLC** for Sanitary Sewer Rehabilitation by Sliplining and Pipe Bursting Methods, (4257-131) - 2.57% over the original contract amount - Enterprise Fund **DISTRICTS A - STARDIG; B - DAVIS; D - BOYKINS; H - CISNEROS; J - LASTER and K - GREEN**

### **Background:**

**SUBJECT:** Accept Work for Sanitary Sewer Rehabilitation by Sliplining and Pipe Bursting Methods.

**RECOMMENDATION:** (Summary) Pass a motion to approve the final contract amount of \$3,936,082.74, which is 2.57% over the original contract amount and under the 5% contingency amount, accept the work, and authorize final payment.

**PROJECT NOTICE/JUSTIFICATION:** Under this project, the contractor provided sanitary sewer rehabilitation by sliplining and pipe bursting methods to deteriorated sewer collection systems throughout the City.

**DESCRIPTION/SCOPE:** This project consisted of sanitary sewer rehabilitation by sliplining and pipe bursting methods. The project was awarded to Portland Utilities Construction Company, LLC with an original contract amount of \$3,837,307.50. The Notice to Proceed date was 3/13/2013 and the project had 540 calendar days for completion.

**LOCATION:** This work order project was located at various locations within Council Districts A, B, D, H, J and K.

**CONTRACT COMPLETION AND COST:** The contractor, Portland Utilities Construction Company, LLC, has completed the work under the contract. The contract was completed within the contract time with an additional 90 days approved by Change Order No. 2. The final cost of the project is \$3,936,082.74, an increase of \$98,775.24 or 2.57% over the original contract amount. More pipe bursting was needed than anticipated.

The final amount of this work order contract was not affected by Change Orders No. 1 and No. 2.

**MWDBE PARTICIPATION:** The MWDBE goal for this project was 24.00%. According to the Office of Business Opportunity, the actual participation was 24.74%. The contractor was awarded an “Satisfactory” rating from the Office of Business Opportunity.

-  

---

Carol Ellinger Haddock, P.E.  
Acting Director  
Department of Public Works and Engineering

WBS# R-000295-0041-4  
File No. 4257-131

**Prior Council Action:**

Ordinance No. 2012-949, dated 11/07/2012

**Amount of Funding:**

No additional funding required.

Original appropriation of \$4,089,173.00 from Water and Sewer System Consolidated Construction Fund No. 8500.

**Contact Information:**

Shannon Dunne  
Acting Senior Assistant Director  
Phone: (832) 395-5036

**ATTACHMENTS:**

**Description**

Signed Coversheet

**Type**

Signed Cover sheet

**CITY OF HOUSTON - CITY COUNCIL**

Meeting Date:

District A, District B, District D, District H, District J, District K

Item Creation Date: 9/21/2017

20WWO717 Accept Work/Portland Utilities Construction Company, LLC

Agenda Item#:

**Background:****SUBJECT:** Accept Work for Sanitary Sewer Rehabilitation by Sliplining and Pipe Bursting Methods.**RECOMMENDATION:** (Summary) Pass a motion to approve the final contract amount of \$3,936,082.74, which is 2.57% over the original contract amount and under the 5% contingency amount, accept the work, and authorize final payment.**PROJECT NOTICE/JUSTIFICATION:** Under this project, the contractor provided sanitary sewer rehabilitation by sliplining and pipe bursting methods to deteriorated sewer collection systems throughout the City.**DESCRIPTION/SCOPE:** This project consisted of sanitary sewer rehabilitation by sliplining and pipe bursting methods. The project was awarded to Portland Utilities Construction Company, LLC with an original contract amount of \$3,837,307.50. The Notice to Proceed date was 3/13/2013 and the project had 540 calendar days for completion.**LOCATION:** This work order project was located at various locations within Council Districts A, B, D, H, J and K.**CONTRACT COMPLETION AND COST:** The contractor, Portland Utilities Construction Company, LLC, has completed the work under the contract. The contract was completed within the contract time with an additional 90 days approved by Change Order No. 2. The final cost of the project is \$3,936,082.74, an increase of \$98,775.24 or 2.57% over the original contract amount. More pipe bursting was needed than anticipated.

The final amount of this work order contract was not affected by Change Orders No. 1 and No. 2.

**MWDBE PARTICIPATION:** The MWDBE goal for this project was 24.00%. According to the Office of Business Opportunity, the actual participation was 24.74%. The contractor was awarded an "Satisfactory" rating from the Office of Business Opportunity.

Handwritten signature of Carol Ellinger Haddock in black ink.

Carol Ellinger Haddock, P.E.

Acting Director

Department of Public Works and Engineering

WBS# R-000295-0041-4

File No. 4257-131

**Prior Council Action:**

Ordinance No. 2012-949, dated 11/07/2012

**Amount of Funding:**

No additional funding required.

Original appropriation of \$4,089,173.00 from Water and Sewer System Consolidated Construction Fund No. 8500.

**Contact Information:**

Shannon Dunne

Acting Senior Assistant Director

Phone: (832) 395-5036

**ATTACHMENTS:**

**Description**

Caption

Council District Map

Council District List

Contract Wage Rate and MWBE Compliance

Performance Evaluation

Prior Council Action

Tax Report

Affidavit of Ownership

Change Orders

**Type**

Backup Material

Backup Material

Backup Material

Backup Material

Backup Material

Backup Material

Backup Material

Backup Material

Backup Material



## CITY OF HOUSTON - CITY COUNCIL

Meeting Date: 11/8/2017

District A

Item Creation Date:

20AVB13 Accept Work / Reytec Construction Resources,  
Inc.

Agenda Item#: 4.

### **Summary:**

RECOMMENDATION from Acting Director Department of Public Works & Engineering, for approval of final contract amount of \$14,578,329.69 and acceptance of work on contract with **REYTEC CONSTRUCTION RESOURCES, INC** for Neighborhood Street Reconstruction Project 465 - 4.70% under the original contract amount - **DISTRICT A - STARDIG**

### **Background:**

**SUBJECT:** Accept Work for Neighborhood Street Reconstruction (NSR) Project 465; WBS Nos. N-000398-0001-4, R-000500-0161-4 and S-000500-0161-4.

**RECOMMENDATION: (SUMMARY)** Pass a motion to approve the final Contract Amount of \$14,578,329.69 or 4.70% under the original Contract Amount, accept the Work and authorize final payment.

**PROJECT NOTICE/JUSTIFICATION:** This project was part of the Capital Improvement Plan which replaces existing residential streets that have been deteriorated beyond economical repair and normal maintenance and improves drainage.

**DESCRIPTION/SCOPE:** This project consisted of neighborhood street reconstruction. The proposed improvements had consisted of concrete roadways with curbs, sidewalks and underground utilities as required. Nathelyne A. Kennedy & Associates designed the project with 600 calendar days allowed for construction. The project was awarded to Reytec Construction Resources, Inc. with an original Contract Amount of \$15,297,832.98.

**LOCATION:** The project area is generally bound by Northwest Freeway (U.S. 290) on the north, Kempwood on the south, Hollister on the east and Campbell on the west. The project is located in Key Map Grids 450G, 450K and 450L.

**CONTRACT COMPLETION AND COST:** The Contractor, Reytec Construction Resources, Inc., has completed the work under the subject Contract. The project was completed beyond the established completion date with an additional 13 days approved by Change Order No. 2. Liquidated damages in the amount of \$49,200.00 for 41 days at \$1,200/day were assessed and reflected in the final payment to the Contractor. The final cost of the project, including overrun and underrun of estimated unit price quantities and previously approved Change Order Nos. 1 and 3 is \$14,578,329.69, a decrease of \$719,503.29 or 4.70% under the original Contract Amount. The

decreased cost is a result of the difference between planned and measured quantities.

**M/WSBE PARTICIPATION:** The advertised M/WBE contract goal for this project was 18.00%. The M/WSBE plan established for this project was 18.06%. According to Office of Business Opportunity, the participation was 17.45%. Contractor's M/WSBE performance evaluation was rated Satisfactory. While the Prime met the contract goal, they did not use one of the originally listed subs. Other certified firms that were not originally proposed were added, which allowed the Prime to meet the goal.

---

Carol Ellinger Haddock, P.E., Acting Director  
Department of Public Works and Engineering

WBS Nos. N-000398-0001-4, R-000500-0161-4 and S-000500-0161-4

**Prior Council Action:**

Ordinance 2014-0651, dated 06/18/2014

**Amount of Funding:**

No additional funding required.

Total (original) appropriation of \$17,809,640.00:

\$4,946,000.00 from Fund 8500 – Water and Sewer System Consolidated Construction Fund

\$12,420,220.00 from Fund 4042A – Street & Traffic Control and Storm Drainage DDSRF-A

\$443,420.00 from Fund 4042 – Street & Traffic Control and Storm Drainage DDSRF

**Contact Information:**

Brian P. Alcott, P.E.

Acting Senior Assistant Director, Capital Projects

**Phone:** (832) 395-2396

**ATTACHMENTS:**

**Description**

Coversheet (revised)

Maps

**Type**

Signed Cover sheet

Backup Material



## CITY OF HOUSTON - CITY COUNCIL

Meeting Date: 11/8/2017

District A

Item Creation Date:

20AVB13 Accept Work / Reytec Construction Resources, Inc.

Agenda Item#: 4.

### **Background:**

**SUBJECT:** Accept Work for Neighborhood Street Reconstruction (NSR) Project 465; WBS Nos. N-000398-0001-4, R-000500-0161-4 and S-000500-0161-4.

**RECOMMENDATION:(SUMMARY)** Pass a motion to approve the final Contract Amount of \$14,578,329.69 or 4.70% under the original Contract Amount, accept the Work and authorize final payment.

**PROJECT NOTICE/JUSTIFICATION:** This project was part of the Capital Improvement Plan which replaces existing residential streets that have been deteriorated beyond economical repair and normal maintenance and improves drainage.

**DESCRIPTION/SCOPE:** This project consisted of neighborhood street reconstruction. The proposed improvements had consisted of concrete roadways with curbs, sidewalks and underground utilities as required. Nathelyne A. Kennedy & Associates designed the project with 600 calendar days allowed for construction. The project was awarded to Reytec Construction Resources, Inc. with an original Contract Amount of \$15,297,832.98.

**LOCATION:** The project area is generally bound by Northwest Freeway (U.S. 290) on the north, Kempwood on the south, Hollister on the east and Campbell on the west. The project is located in Key Map Grids 450G, 450K and 450L.

**CONTRACT COMPLETION AND COST:** The Contractor, Reytec Construction Resources, Inc., has completed the work under the subject Contract. The project was completed beyond the established completion date with an additional 13 days approved by Change Order No. 2. Liquidated damages in the amount of \$49,200.00 for 41 days at \$1,200/day were assessed and reflected in the final payment to the Contractor. The final cost of the project, including overrun and underrun of estimated unit price quantities and previously approved Change Order Nos. 1 and 3 is \$14,578,329.69, a decrease of \$719,503.29 or 4.70% under the original Contract Amount. The decreased cost is a result of the difference between planned and measured quantities.

**M/WSBE PARTICIPATION:** The advertised M/WBE contract goal for this project was 18.00%. The M/WSBE plan established for this project was 18.06%. According to Office of Business Opportunity, the participation was 17.45%. Contractor's M/WSBE performance evaluation was rated Satisfactory. While the Prime met the contract goal, they did not use one of the originally listed subs. Other certified firms that were not originally proposed were added, which allowed the Prime to meet the goal.

Carol Ellinger Haddock, P.E., Acting Director  
Department of Public Works and Engineering

WBS Nos. N-000398-0001-4, R-000500-0161-4 and S-000500-0161-4

### **Prior Council Action:**

Ordinance 2014-0651, dated 06/18/2014

### **Amount of Funding:**

No additional funding required.

Total (original) appropriation of \$17,809,640.00:

\$4,946,000.00 from Fund 8500 – Water and Sewer System Consolidated Construction Fund

\$12,420,220.00 from Fund 4042A – Street & Traffic Control and Storm Drainage DDSRF-A

\$443,420.00 from Fund 4042 – Street & Traffic Control and Storm Drainage DDSRF

### **Contact Information:**

Brian P. Alcott, P.E.

Acting Senior Assistant Director, Capital Projects

Phone: (832) 395-2396

**ATTACHMENTS:**

**Description**

Signed Coversheet  
Maps  
OBO  
Prior Council Action  
Change Order Nos 1-3  
Affidavit of Ownership  
Tax Report

**Type**

Signed Cover sheet  
Backup Material  
Backup Material  
Backup Material  
Backup Material  
Backup Material  
Backup Material

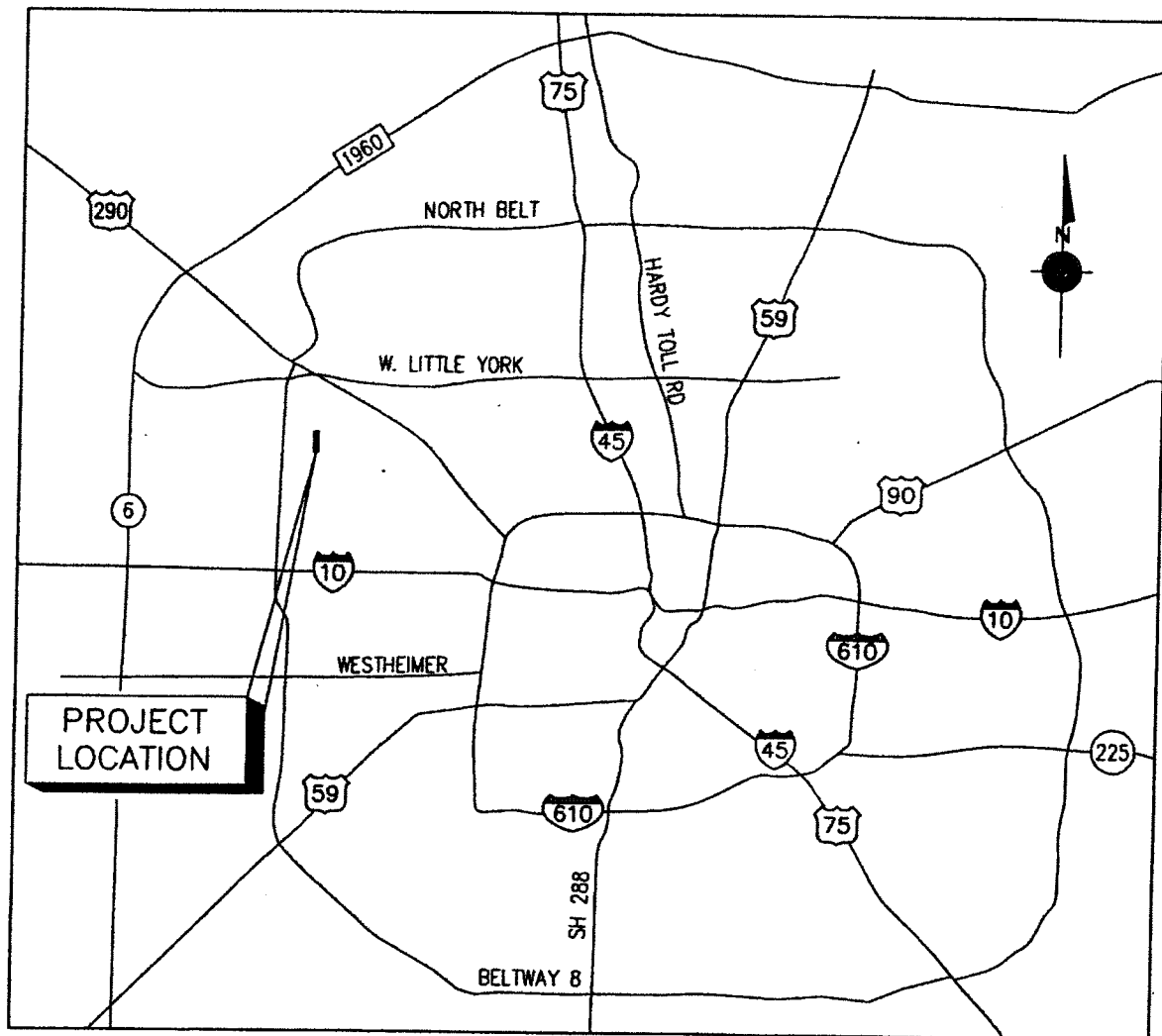

NEIGHBORHOOD STREET RECONSTRUCTION PROJECT (NSR-465)

COUNCIL DISTRICT A

WBS NO. N-000398-0001-3

OUTLINE AGREEMENT NO. 4600010062

LOCATION MAP

NTS

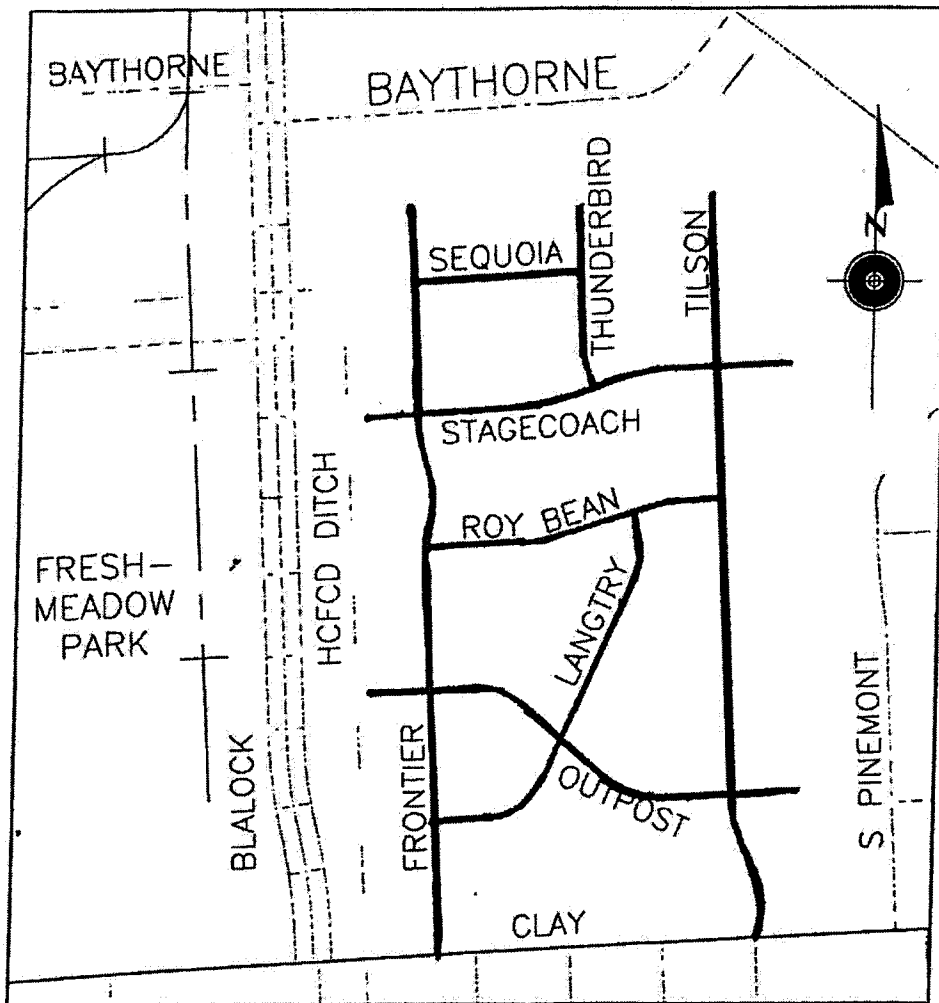

## VICINITY MAP

KEY MAP G  
GIMS MAP #5060a

NEIGHBORHOOD STREET RECONSTRUCTION PROJECT NSR-465  
COUNCIL DISTRICT A  
WBS NO. N000398-0001-3  
OUTLINE AGREEMENT NO. 4600010062

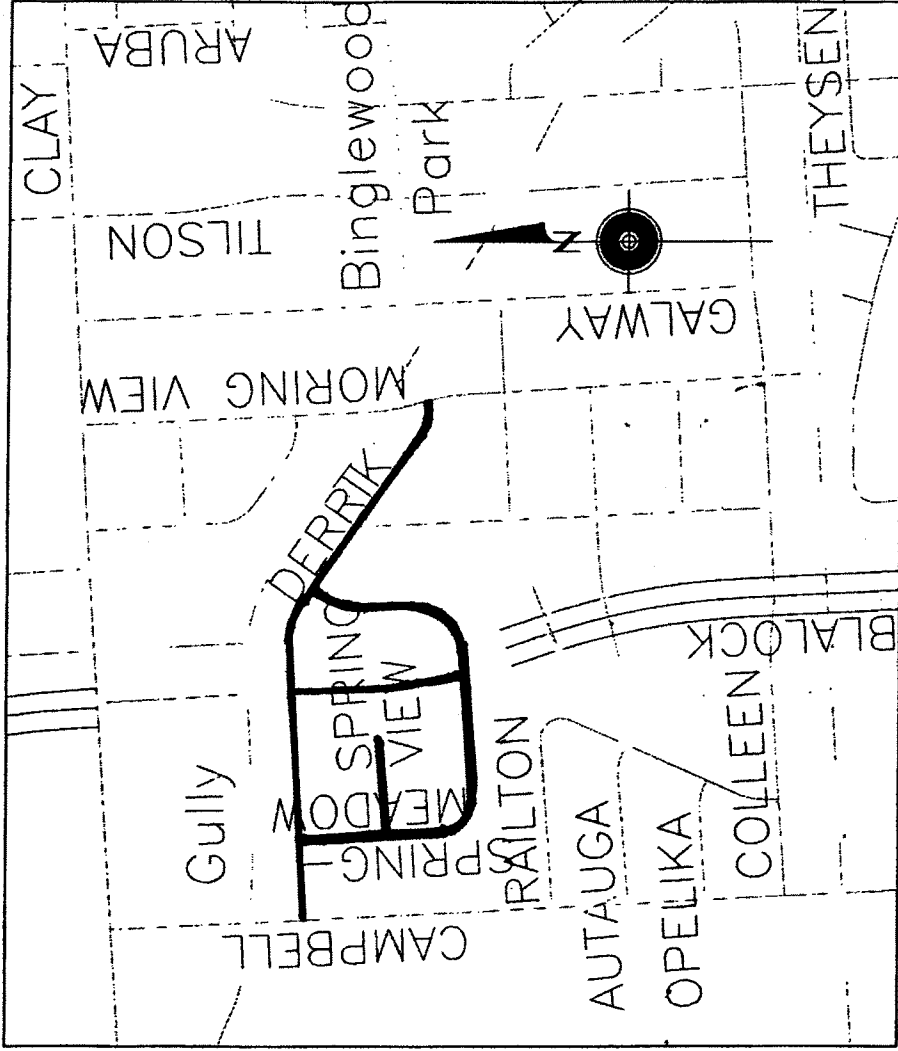

VICINITY MAP

KEY MAP 450 K, L  
GIMS MAP #5060c

NEIGHBORHOOD STREET RECONSTRUCTION PROJECT NSR-465  
COUNCIL DISTRICT A  
WBS NO. N000398-0001-3  
OUTLINE AGREEMENT NO. 4600010062

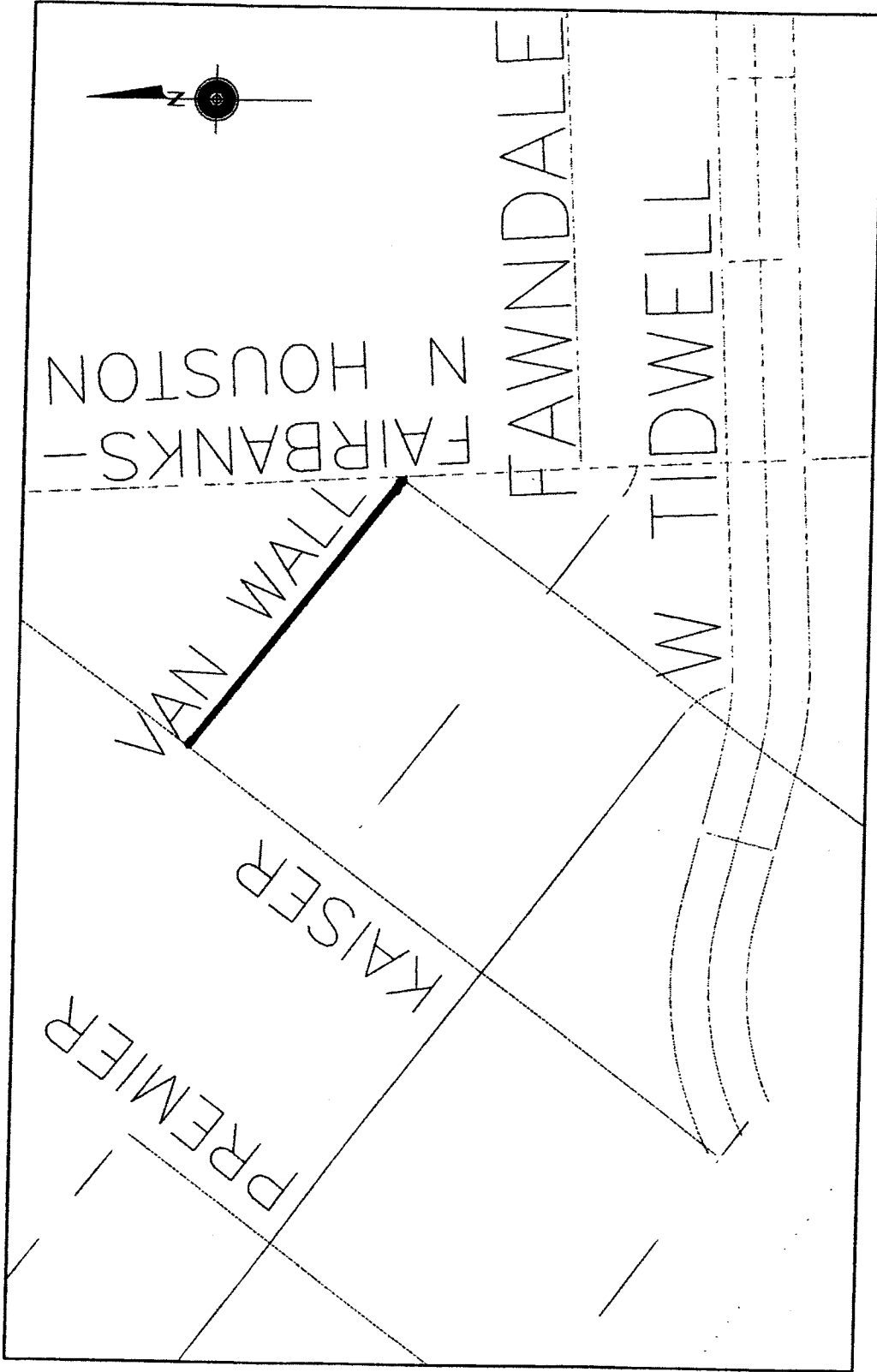

VICINITY MAP

KEY MAP 450 B

GIMS MAP #5061c

NEIGHBORHOOD STREET RECONSTRUCTION PROJECT NSR-465  
 COUNCIL DISTRICT A  
 WBS NO. N000398-0001-3  
 OUTLINE AGREEMENT NO. 4600010062



## CITY OF HOUSTON - CITY COUNCIL

Meeting Date: 11/8/2017

District A

Item Creation Date: 9/15/2017

20PSK06 Accept Work / SER Construction Partners, LLC

Agenda Item#: 5.

### **Summary:**

RECOMMENDATION from Acting Director Department of Public Works & Engineering, for approval of final contract amount of \$5,724,203.67 and acceptance of work on contract with **SER CONSTRUCTION PARTNERS, LLC** for Silber Paving & Drainage from IH 10 to Hartland 2.90% under the original contract amount - **DISTRICT A - STARDIG**

### **Background:**

**SUBJECT:** Accept Work for Silber Paving & Drainage from IH 10 to Hartland; WBS No. N-000812-0001-4, R-000500-0183-4, S-000500-0183-4

**RECOMMENDATION: (SUMMARY)** Pass a motion to approve the final Contract Amount of \$5,724,203.67 or 2.90% under the original Contract Amount, accept the Work and authorize final payment.

**PROJECT NOTICE/JUSTIFICATION:** This project was part of the Street and Traffic Capital Improvement Project and was necessary to meet City of Houston design and safety standards and improve traffic mobility and drainage in the service area.

**DESCRIPTION/SCOPE:** The project consisted of the construction of approximately 2,300 linear feet of roadway reconstruction to major thoroughfare or collector street standards. The proposed project improvements include a four-lane concrete roadway with curbs, an underground storm sewer system, sidewalks, street lights and necessary utilities. Midtown Engineers, LLC designed the project with 343 calendar days allowed for construction. The project was awarded to SER Construction Partners, LLC with an original Contract amount of \$5,895,132.60.

**LOCATION:** This project is located in Council District A. The project area is generally bound by Hartland Street on the north, IH-10 on the south, Post Oak Road on the east and Antoine Drive on the west. The project is located in Key Map Grid 491C.

**CONTRACT COMPLETION AND COST:** The Contractor, SER Construction Partners, LLC, has completed the work under the subject Contract. The project was completed within the original Contract time. The final cost of the project, including overrun and underrun of estimated unit price quantities and previously approved Change Order No. 1 is \$5,724,203.67, a decrease of \$170,928.93 or 2.90% under the original Contract Amount and under 5% contingency amount. The decreased cost is a result of the difference between planned and measured quantities.

**M/WSBE PARTICIPATION:** The advertised M/WBE contract goal for this project was 18.00%. The M/WSBE plan established for this project was 18.00%. According to the Office of Business Opportunity, the participation was 26.01%. Contractor's M/WSBE performance evaluation was

rated Outstanding for goal compliance.

---

Carol Ellinger Haddock, P.E., Acting Director  
Department of Public Works and Engineering

WBS No. N-000812-0001-4

**Prior Council Action:**

Ordinance 2016-0209, dated 03/23/2016

**Amount of Funding:**

No additional funding required.

Total (original) appropriation of \$6,851,500.00:

\$3,688,727.00 from Fund 4040 – METRO Projects Construction DDSRF

\$1,885,782.00 from Fund 4042 – Street & Traffic Control and Storm Drainage DDSRF

\$1,276,991.00 from Fund 8500 – Water and Sewer System Consolidated Construction Fund

**Contact Information:**

Brian P. Alcott, P.E.

Acting Senior Assistant Director, Capital Projects

Phone: (832) 395-2396

**ATTACHMENTS:**

**Description**

Signed Coversheet

Maps

**Type**

Signed Cover sheet

Backup Material



## CITY OF HOUSTON - CITY COUNCIL

Meeting Date:

District A

Item Creation Date: 9/15/2017

20PSK06 Accept Work / SER Construction Partners, LLC

Agenda Item#:

### **Background:**

**SUBJECT:** Accept Work for Silber Paving & Drainage from IH 10 to Hartland; WBS No. N-000812-0001-4, R-000500-0183-4, S-000500-0183-4

**RECOMMENDATION: (SUMMARY)** Pass a motion to approve the final Contract Amount of \$5,724,203.67 or 2.90% under the original Contract Amount, accept the Work and authorize final payment.

**PROJECT NOTICE/JUSTIFICATION:** This project was part of the Street and Traffic Capital Improvement Project and was necessary to meet City of Houston design and safety standards and improve traffic mobility and drainage in the service area.

**DESCRIPTION/SCOPE:** The project consisted of the construction of approximately 2,300 linear feet of roadway reconstruction to major thoroughfare or collector street standards. The proposed project improvements include a four-lane concrete roadway with curbs, an underground storm sewer system, sidewalks, street lights and necessary utilities. Midtown Engineers, LLC designed the project with 343 calendar days allowed for construction. The project was awarded to SER Construction Partners, LLC with an original Contract amount of \$5,895,132.60.

**LOCATION:** This project is located in Council District A. The project area is generally bound by Hartland Street on the north, IH-10 on the south, Post Oak Road on the east and Antoine Drive on the west. The project is located in Key Map Grid 491C.

**CONTRACT COMPLETION AND COST:** The Contractor, SER Construction Partners, LLC, has completed the work under the subject Contract. The project was completed within the original Contract time. The final cost of the project, including overrun and underrun of estimated unit price quantities and previously approved Change Order No. 1 is \$5,724,203.67, a decrease of \$170,928.93 or 2.90% under the original Contract Amount and under 5% contingency amount. The decreased cost is a result of the difference between planned and measured quantities.

**M/WSBE PARTICIPATION:** The advertised M/WBE contract goal for this project was 18.00%. The M/WSBE plan established for this project was 18.00%. According to the Office of Business Opportunity, the participation was 26.01%. Contractor's M/WSBE performance evaluation was rated Outstanding for goal compliance.

  
Carol Ellinger Hadlock, P.E., Acting Director  
Department of Public Works and Engineering

WBS No. N-000812-0001-4

### **Prior Council Action:**

Ordinance 2016-0209, dated 03/23/2016

### **Amount of Funding:**

No additional funding required.

Total (original) appropriation of \$6,851,500.00:

\$3,688,727.00 from Fund 4040 – METRO Projects Construction DDSRF

\$1,885,782.00 from Fund 4042 – Street & Traffic Control and Storm Drainage DDSRF

\$1,276,991.00 from Fund 8500 – Water and Sewer System Consolidated Construction Fund

### **Contact Information:**

Brian P. Alcott, P.E.

Acting Senior Assistant Director, Capital Projects

Phone: (832) 395-2396

**ATTACHMENTS:**

**Description**

Maps

OBO

Affidavit of Ownership

Tax Report

Prior Council Action

Change Order 1

**Type**

Backup Material

Backup Material

Backup Material

Backup Material

Backup Material

Backup Material

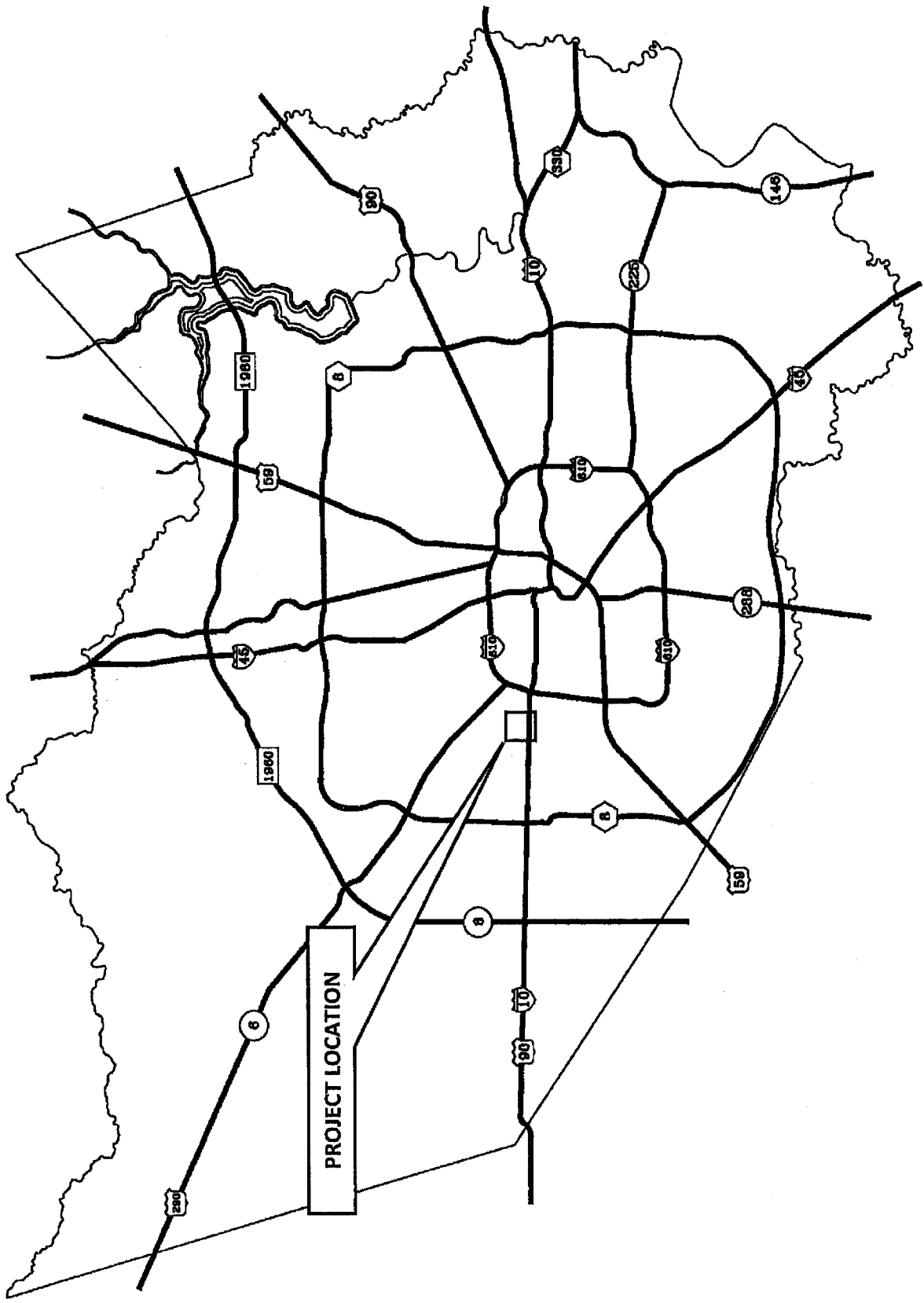

PROJECT LOCATION

SILBER PAVING AND DRAINAGE FROM IH-10 TO NORTH OF HARTLAND  
VICINITY MAP  
WBS No. N-000812-0001-3



KEY MAP: 491 C  
GIMS GRID: 51.58 B  
CITY OF HOUSTON COUNCIL DISTRICT: A  
COUNCIL MEMBER: BRENDA STARDIG

**Midtown Engineers, LLC**  
5225 KATY FREEWAY, SUITE 400 HOUSTON, TX 77007  
(713) 862-8848 WWW.MIDTOWNENGINEERS.COM  
TBPE NO. F-8934

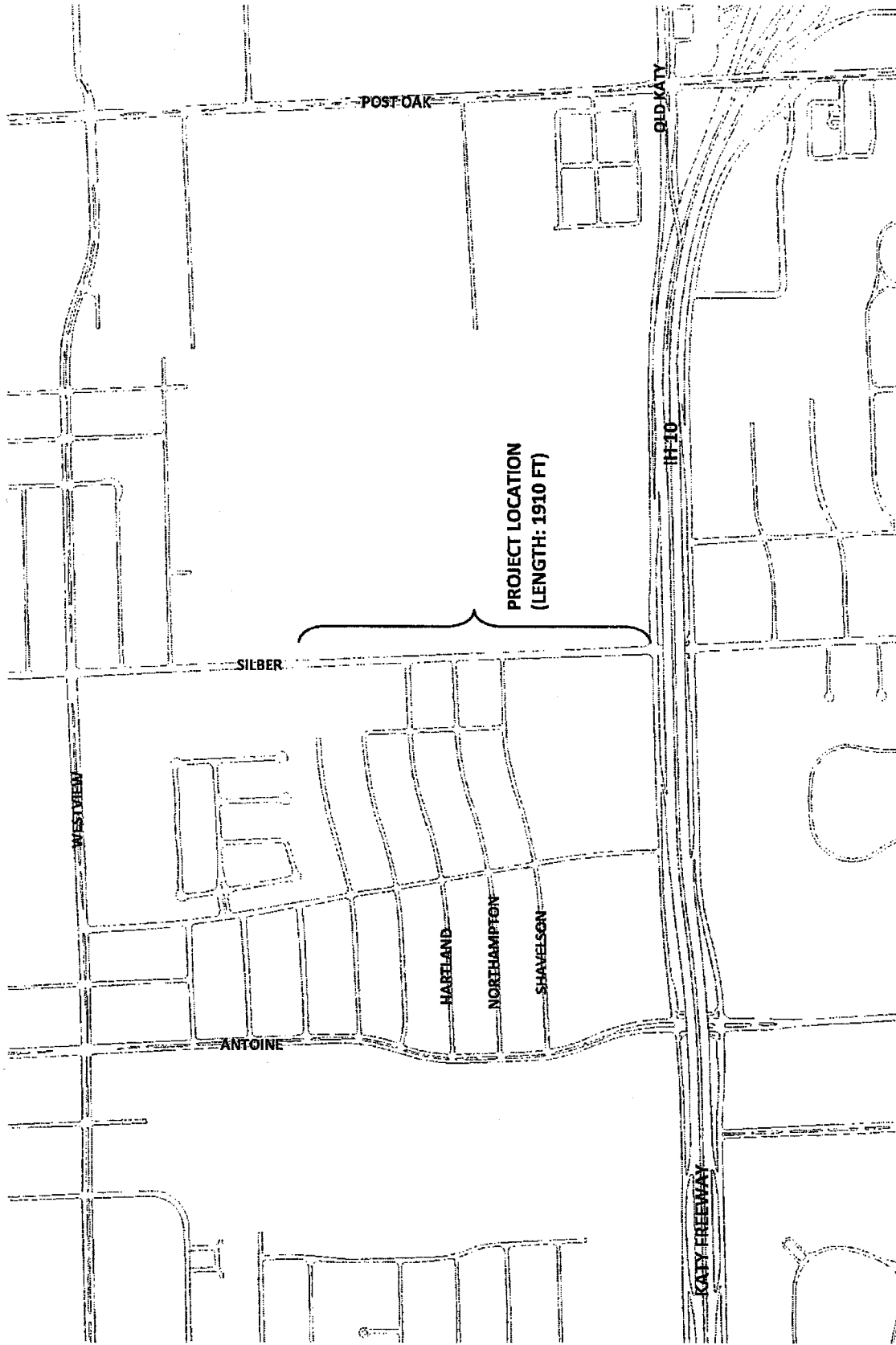

SILBER PAVING AND DRAINAGE FROM IH-10 TO NORTH OF HARTLAND  
 LOCATION MAP  
 WBS No. N-000812-0001-3



KEY MAP: 491 C  
 GIMS GRID: 5158 B  
 CITY OF HOUSTON COUNCIL DISTRICT: A  
 COUNCIL MEMBER: BRENDA STARDIG

**Midtown Engineers, LLC**  
 5225 KATY FREEWAY, SUITE 400 HOUSTON, TX 77007  
 (713) 862-8848 WWW.MIDTOWNEENGINEERS.COM  
 TBPE NO. F-8934



## CITY OF HOUSTON - CITY COUNCIL

Meeting Date: 11/8/2017

ALL

Item Creation Date: 10/5/2017

H26413 - Digital Sandbox System Software Enhancements &  
Support Services -MOTION

Agenda Item#: 6.

### **Summary:**

**DIGITAL SANDBOX, INC** for purchase of Software Enhancements and Support Services for the Digital Sandbox System from the General Services Administration Schedule 70 Contract through the Cooperative Purchasing Program for the Mayor's Office of Public Safety and Homeland Security - \$193,000.00 - Grant Fund

### **Background:**

**S17-H26413 - Purchase of software enhancements & support services for the Digital Sandbox system from the General Services Administration (GSA) Schedule 70 contract through the Cooperative Purchasing Program in the total amount of \$193,000.00 for the Mayor's Office of Public Safety and Homeland Security.**

### **Specific Explanation:**

The Director of the Mayor's Office of Public Safety and Homeland Security and the Chief Procurement Officer recommend that City Council approve the purchase of software enhancements & support services for the Digital Sandbox system from the General Services Administration (GSA) Schedule 70 contract through the Cooperative Purchasing Program in the total amount of **\$193,000.00** for the Mayor's Office of Public Safety and Homeland Security and that authorization be given to issue purchase orders, as necessary, to the GSA contractor, **Digital Sandbox, Inc.**

The Mayor's Office of Public Safety and Homeland Security seeks to enhance the Digital Sandbox system, a proprietary risk management software system that Houston administers for the 13 counties of the Houston-Galveston Area Council (H-GAC) region. These enhancements will expand capabilities of public safety personnel by adding a Rapid Assessment Tool, allowing first responders to quickly assess a location for life safety issues and identification of stored hazardous materials. Additionally, a reporting feature will be enabled to assist in the prioritization of these locations which will support a more involved fire assessment. Service hours will be included to obtain the additional support of software engineers during scheduled and unscheduled "large scaled" events/incidents. Additional enhancements to the system will assist all disciplines (police, fire, and emergency management) by enabling a GIS based reporting feature that captures specific information of resources and assets found in a determined area. These enhancements will provide the City of Houston and H-GAC counties throughout the region additional tools to better evaluate an asset's vulnerabilities, risks and hazards. Risk-based resource allocation is required under the National Preparedness Guidelines. Furthermore, the National Infrastructure Protection Plan requires state and local governments to utilize risk management methodologies in their implementation of infrastructure protection efforts.

### **M/WBE Participation:**

Zero-Percentage Goal document approved by the Office of Business Opportunity.

### **Hire Houston First:**

This procurement is exempt from the City of Houston First Ordinance. Bid/Proposal must not include

This procurement is exempt from the City's Hire Houston First Ordinance. Bids/proposals were not solicited because the department is utilizing a Cooperative Purchasing Agreement for this purchase.

**Fiscal Note:**

This is a grant funded item. Therefore, no Fiscal Note is required as stated in the Financial Policy Ord. 2014-1078.

---

**Jerry Adams, Chief Procurement Officer**  
Finance/Strategic Procurement Division

---

**Department Approval Authority**

**Amount of Funding:**

**\$193,000.00** - Federal State Local - Pass Through Fund (5030)

**Contact Information:**

NAME:	DEPARTMENT/ DIVISION	PHONE
Martin King, Division Manager	FIN/SPD	(832) 393-8705
Murdock Smith, Sr. Procurement Specialist	FIN/SPD	(832) 393-8725
Dennis Storemski, Director	MYR	(832) 393-0875

**ATTACHMENTS:**

**Description**

Cover Sheet

**Type**

Signed Cover sheet



**CITY OF HOUSTON - CITY COUNCIL**

Meeting Date: 11/8/2017

ALL

Item Creation Date: 10/5/2017

H26413 - Digital Sandbox System Software Enhancements & Support Services -MOTION

Agenda Item#: 5.

**Background:**

S17-H26413 - Purchase of software enhancements & support services for the Digital Sandbox system from the General Services Administration (GSA) Schedule 70 contract through the Cooperative Purchasing Program in the total amount of \$193,000.00 for the Mayor's Office of Public Safety and Homeland Security.

**Specific Explanation:**

The Director of the Mayor's Office of Public Safety and Homeland Security and the Chief Procurement Officer recommend that City Council approve the purchase of software enhancements & support services for the Digital Sandbox system from the General Services Administration (GSA) Schedule 70 contract through the Cooperative Purchasing Program in the total amount of \$193,000.00 for the Mayor's Office of Public Safety and Homeland Security and that authorization be given to issue purchase orders, as necessary, to the GSA contractor, **Digital Sandbox, Inc.**

The Mayor's Office of Public Safety and Homeland Security seeks to enhance the Digital Sandbox system, a proprietary risk management software system that Houston administers for the 13 counties of the Houston Galveston Area Council (H-GAC) region. These enhancements will expand capabilities of public safety personnel by adding a Rapid Assessment Tool, allowing first responders to quickly assess a location for life safety issues and identification of stored hazardous materials. Additionally, a reporting feature will be enabled to assist in the prioritization of these locations which will support a more involved fire assessment. Service hours will be included to obtain the additional support of software engineers during scheduled and un-scheduled "large scaled" events/incidents. Additional enhancements to the system will assist all disciplines (police, fire, and emergency management) by enabling a GIS based reporting feature that captures specific information of resources and assets found in a determined area. These enhancements will provide the City of Houston and H-GAC counties throughout the region additional tools to better evaluate an asset's vulnerabilities, risks and hazards. Risk-based resource allocation is required under the National Preparedness Guidelines. Furthermore, the National Infrastructure Protection Plan requires state and local governments to utilize risk management methodologies in their implementation of infrastructure protection efforts.

**M/WBE Participation:**

Zero-Percentage Goal document approved by the Office of Business Opportunity.

**Hire Houston First:**

This procurement is exempt from the City's Hire Houston First Ordinance. Bids/proposals were not solicited because the department is utilizing a Cooperative Purchasing Agreement for this purchase.

**Fiscal Note:**

This is a grant funded item. Therefore, no Fiscal Note is required as stated in the Financial Policy Ord. 2014-1078.

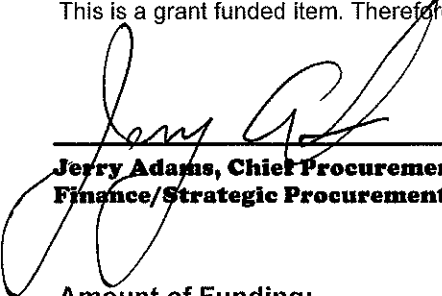
  
\_\_\_\_\_  
**Jerry Adams, Chief Procurement Officer**  
**Finance/Strategic Procurement Division**

\_\_\_\_\_  
**Department Approval Authority**

**Amount of Funding:**

\$193,000.00 - Federal State Local - Pass Through Fund (5030)

**Contact Information:**

<u>NAME:</u>	<u>DEPARTMENT/ DIVISION</u>	<u>PHONE</u>
Martin King, Division Manager	FIN/SPD	(832) 393-8705
Murdock Smith, Sr. Procurement Specialist	FIN/SPD	(832) 393-8725
Dennis Storemski, Director	MYR	(832) 395-9703

**ATTACHMENTS:**

<u>Description</u>	<u>Type</u>
<u>MWBE Waiver</u>	Backup Material
<u>Form A (Fair Campaign)</u>	Backup Material
<u>Form B</u>	Backup Material
<u>Cleared Tax Report</u>	Backup Material
<u>Affidavit of Ownership</u>	Backup Material
<u>Quote</u>	Backup Material



## CITY OF HOUSTON - CITY COUNCIL

Meeting Date: 11/8/2017

Item Creation Date:

FIN – GO Public Improvement Bonds, Series 2017A

Agenda Item#: 7.

### **Summary:**

ORDINANCE authorizing one or more series of City of Houston, Texas Public Improvement Refunding Bonds as may be further designated, described and provided herein; authorizing the payment and security thereof and certain designated officials to approve the principal amount, interest rates, prices, terms and sale thereof in accordance with the parameters described herein; authorizing such officials to determine the outstanding obligations to be refunded and/or defeased; approving certain other procedures, provisions and agreements related thereto, including authorizing the execution and delivery of one or more purchase contracts, Paying Agent/Registrar Agreements, Escrow Agreements, and other agreements; approving the preparation, distribution and use of a Preliminary Official Statement and Official Statement in connection with such offering; authorizing the engagement of Bond Counsel and Special Disclosure Counsel; making certain findings and other declarations necessary and incidental to the issuance of such refunding bonds; and declaring an emergency

### **Background:**

**SUBJECT:** Ordinance authorizing the issuance and sale of the Public Improvement Refunding Bonds, Series 2017A and such other series as may be required to refund and defease certain outstanding obligations of the City; authorizing a Preliminary Official Statement, Official Statement and related agreements pertaining to such bonds.

**RECOMMENDATION:** Approve an Ordinance authorizing the issuance and sale of the City of Houston, Texas, Public Improvement Refunding Bonds Series 2017A and such other series as may be determined, in an aggregate amount not to exceed \$645 million; authorizing certain designated city officials to approve the principal amount, interest rates, prices, terms and sale thereof; authorizing such officials to determine the outstanding obligations to be refunded and/or defeased. Approving the use of a preliminary official statement and authorizing the preparation and distribution of an official statement in connection with such offering.

### **SPECIFIC EXPLANATION:**

The Finance Working Group (the "FWG") is recommending refunding certain outstanding general obligation commercial paper notes, certain outstanding general obligation bonds and financing all related costs of issuance.

### **Commercial Paper**

The City has been issuing short term commercial paper to fund its Capital Improvement Program and equipment procurements for over 20 years. Consistent with the City's financial policies, outstanding general obligation, commercial paper notes are refinanced with long term fixed rate bonds with a final maturity to match the useful life of the capital improvement project or equipment financed with such commercial paper. This transaction represents the normal refunding of these commercial paper notes with long term fixed rate refunding bonds. Based on current market conditions, the intent is to refund up to \$250 million of outstanding commercial paper notes.

**Current and Advance Bond Refunding**

In addition to the refunding of general obligation commercial paper, the City anticipates refunding certain outstanding public improvement bonds to achieve present value debt service savings on an aggregate basis. The FWG is reviewing current outstanding debt for refunding opportunities. All refundings would meet the parameters established under the City's adopted financial policies.

**Summary**

The following table further summarizes the approximate allocation of the combined proposed transaction:

**Public Improvement Refunding Bonds Series 2017A**

	<b>Refunding Component</b>	<b>Up To</b>	<b>Use</b>
A.	Refund CP Series G, H, J	\$179,900,000	Capital Improvements
B.	Refund CP Series E	\$70,000,000	Equipment
C.	Current and Advance Refundings	\$395,100,000	Refunding and Cost of Issuance
<b>Total</b>		<b>\$645,000,000</b>	

**Recommendation**

This transaction was presented to the Budget and Fiscal Affairs Committee on March 7, 2017.

The Finance Working Group recommends the PIB Series 2017A be issued through a negotiated financing with Goldman Sachs serving as book running manager along with Hutchinson, Shockey, Erley & Co. and Siebert Cisneros Shank & Co., L.L.C. as co-senior managers. The Williams Capital Group, George K. Baum and Fidelity Capital Markets are recommended as co-managers. Bracewell LLP and Baker Williams & Matthiesen LLP are recommended as co-bond counsel along with Greenberg Traurig LP and Burney & Foreman as co-disclosure counsel.

**Contact Information:**

Melissa Dubowski  
Charisse Mosely

**Phone:** 832-393-9101  
**Phone:** 832-393-3529



## CITY OF HOUSTON - CITY COUNCIL

Meeting Date: 11/8/2017

District D

Item Creation Date: 10/31/2017

HCD17-101 Implementation of Provisions to Use Section  
108 Loan Funds

Agenda Item#: 8.

### **Summary:**

ORDINANCE pursuant to and implementing the provisions of Ordinance No. 2017-168, approving and authorizing the City to borrow from the United States Department of Housing and Urban Development ("HUD") \$5,062,000.00 of loan funds provided under Section 108 of the Housing and Community Development Act of 1974 ("Section 108"); appropriating \$5,062,000.00 of Section 108 Funds and allocating \$8,800,000.00 of Economic Development Initiative Grant Funds to fund the purchase of approximately 9.177 acres of land out of the G.P. Foster Survey, Abstract No. 273, Harris County, Texas, for a purchase price of \$13,850,000.00 and related closing costs of \$12,000.00; approving and authorizing a contract for loan guarantee assistance, a promissory note, and related documents between the City of Houston and HUD relating to the loan of the Section 108 Funds - **DISTRICT D - BOYKINS**

### **Background:**

The Housing and Community Development Department (HCDD) requests City Council approval of an Ordinance implementing provisions of Ordinance No. 2017-168, approving and authorizing the City to borrow \$5,062,000 in Section 108 Loan Funds from the United States Department of Housing and Urban Development (HUD), and to allocate \$8,800,000 in Economic Development Initiative (EDI) Funds to fund the purchase from Houston Community College (HCC) of approximately 9.177 acres of land located at the NE Corner of HWY 288 and N MacGregor (the "Property") at a purchase price of \$13,850,000 and related closing costs of \$12,000. HUD has now approved the City's application to borrow the Section 108 Loan Funds and to allocate the EDI Funds for the purchase of the Property. This Ordinance will approve and authorize a contract for loan guarantee assistance, a promissory note, and related documents between the City and HUD for the Section 108 Loan Funds.

On March 8, 2017, by Ordinance No. 2017-168, the City Council authorized the submission of applications to HUD for the use of Section 108 and EDI Funds to fund the purchase of the Property and approved the related Purchase and Sale Agreement between the City and HCC.

On October 18, 2017 City Council approved Ordinance No. 2017-809 for a lease and development agreement between the City and the Houston Housing Finance Corporation (HHFC), which will become effective at time of closing. HHFC will be sub-leasing to HEB, which has committed to the construction of a full-service grocery store.

HCDD respectfully requests City Council approval of this Ordinance, which is required in order for the City to access the Section 108 Loan Funds.

---

Tom McCasland, Director

**Prior Council Action:**

3/8/2017, (O) 2017-168

10/18/2017, (O) 2017-809

**Amount of Funding:**

\$5,062,000.00 - Section 108 Loan - Fund 5000

\$8,800,000.00 - Economic Development Initiative (EDI) - Fund 5000

**Contact Information:**

Roxanne Lawson

832.394.6307

**ATTACHMENTS:**

**Description**

Cover Sheet

**Type**

Signed Cover sheet



## CITY OF HOUSTON - CITY COUNCIL

Meeting Date:

District D

Item Creation Date: 10/31/2017

HCD17-101 Implementation of Provisions to Use Section 108  
Loan Funds

Agenda Item#:

### **Background:**

The Housing and Community Development Department (HCDD) requests City Council approval of an Ordinance implementing provisions of Ordinance No. 2017-168, approving and authorizing the City to borrow \$5,062,000 in Section 108 Loan Funds from the United States Department of Housing and Urban Development (HUD), and to allocate \$8,800,000 in Economic Development Initiative (EDI) Funds to fund the purchase from Houston Community College (HCC) of approximately 9.177 acres of land located at the NE Corner of HWY 288 and N MacGregor (the "Property") at a purchase price of \$13,850,000 and related closing costs of \$12,000. HUD has now approved the City's application to borrow the Section 108 Loan Funds and to allocate the EDI Funds for the purchase of the Property. This Ordinance will approve and authorize a contract for loan guarantee assistance, a promissory note, and related documents between the City and HUD for the Section 108 Loan Funds.

On March 8, 2017, by Ordinance No. 2017-168, the City Council authorized the submission of applications to HUD for the use of Section 108 and EDI Funds to fund the purchase of the Property and approved the related Purchase and Sale Agreement between the City and HCC.

On October 18, 2017 City Council approved Ordinance No. 2017-809 for a lease and development agreement between the City and the Houston Housing Finance Corporation (HHFC), which will become effective at time of closing. HHFC will be sub-leasing to HEB, which has committed to the construction of a full-service grocery store.

HCDD respectfully requests City Council approval of this Ordinance, which is required in order for the City to access the Section 108 Loan Funds.

  
\_\_\_\_\_  
Tom McCasland, Director

### **Prior Council Action:**

3/8/2017, (O) 2017-168

10/18/2017, (O) 2017-809

**Amount of Funding:**

\$5,062,000.00 - Section 108 Loan - Fund 5000

\$8,800,000.00 - Economic Development Initiative (EDI) - Fund 5000

**Contact Information:**

Roxanne Lawson

832.394.6307



## CITY OF HOUSTON - CITY COUNCIL

Meeting Date: 11/8/2017

District H

Item Creation Date: 9/29/2017

20TP9731/Abandonment and Sale of Felix Street/SY17-045

Agenda Item#: 9.

### **Summary:**

ORDINANCE finding and determining that public convenience and necessity no longer require the continued use of Felix Street, from Harrisburg Street south to its terminus, located within the Harrisburg Market Subdivision out of the S.M. Williams Survey, A-87; vacating and abandoning the street easement to **BakerRipley and Harrisburg Blue Willow, Ltd.**, the abutting owners, in consideration of their payment to the City of \$245,959.00, and other consideration - **DISTRICT H - CISNEROS**

### **Background:**

**SUBJECT:** Ordinance authorizing the abandonment and sale of Felix Street, from Harrisburg Street south to its terminus, located within the Harrisburg Market Subdivision out of the S.M. Williams Survey, A-87. **Parcels SY17-045 and SY17-051**

**RECOMMENDATION:** (Summary) It is recommended City Council approve an ordinance authorizing the abandonment and sale of Felix Street, from Harrisburg Street south to its terminus, in exchange for a consideration of \$245,959.00, located within the Harrisburg Market Subdivision out of the S.M. Williams Survey, A-87. **Parcels SY17-045 and SY17-051**

### **SPECIFIC EXPLANATION:**

Geoff Carleton, AICP of Traffic Engineers, Inc. on behalf of BakerRipley (formerly known as Neighborhood Centers, Inc., [Annise Parker, Senior Vice President and Chief Strategy Officer], General Partner), and Harrisburg Blue Willow, Ltd. (Harrisburg Blue Willow GP, LLC [Linda Schmuck, President], General Partner), requested the abandonment and sale of Felix Street, from Harrisburg Street south to its terminus, located within the Harrisburg Market Subdivision out of the S.M. Williams Survey, A-87. Harrisburg Blue Willow, Ltd. plans to sell the portion abutting its property to BakerRipley following the passage of the ordinance for the subject street abandonment. BakerRipley plans to expand and develop BakerRipley as its corporate headquarters. The development will include a four-story retail building, office facility, and job skills improvement center.

BakerRipley and Harrisburg Blue Willow, Ltd. have complied with the transaction requirements, have accepted the City's offer, and have rendered payment in full.

The City will abandon and sell to BakerRipley:

**Parcel SY17-045**

4,071 square-foot right of way easement: \$117,001.00 (R)  
Valued at \$28.74 PSF x 100%

Depreciated cost of improvements \$4,511.00  
(concrete curbing and pavement)

TOTAL ABANDONMENT: \$121,512.00 (R)

The City will abandon and sell to Harrisburg Blue Willow, Ltd.:

**Parcel SY17-051**

4,177 square-foot right of way easement: \$120,047.00 (R)  
Valued at \$28.74 PSF x 100%

Depreciated cost of improvements \$4,400.00  
(concrete curbing and pavement)

TOTAL ABANDONMENT: \$124,447.00 (R)

**TOTAL ABANDONMENTS: \$245,959.00 (R)**

Therefore, it is recommended City Council approve an Ordinance authorizing the abandonment and sale of Felix Street, from Harrisburg Street south to its terminus, located within the Harrisburg Market Subdivision out of the S.M. Williams Survey, A-87

---

**Carol Ellinger Haddock, P.E. Acting Director**  
**Department of Public Works and Engineering**

**Contact Information:**

Darrin Ward  
Acting Senior Assistant Director-Real Estate Services  
(832) 395-3154

**ATTACHMENTS:**

**Description**

Signed Coversheet  
Council District Map  
Approved Parcel Drawing

**Type**

Signed Cover sheet  
Backup Material  
Backup Material



**CITY OF HOUSTON - CITY COUNCIL**

Meeting Date:

District H

Item Creation Date: 9/29/2017

20TP9731/Abandonment and Sale of Felix Street/SY17-045

Agenda Item#:

**Background:**

**SUBJECT:** Ordinance authorizing the abandonment and sale of Felix Street, from Harrisburg Street south to its terminus, located within the Harrisburg Market Subdivision out of the S.M. Williams Survey, A-87. **Parcels SY17-045 and SY17-051**

**RECOMMENDATION:** (Summary) It is recommended City Council approve an ordinance authorizing the abandonment and sale of Felix Street, from Harrisburg Street south to its terminus, in exchange for a consideration of \$245,959.00, located within the Harrisburg Market Subdivision out of the S.M. Williams Survey, A-87. **Parcels SY17-045 and SY17-051**

**SPECIFIC EXPLANATION:**

Geoff Carleton, AICP of Traffic Engineers, Inc. on behalf of BakerRipley (formerly known as Neighborhood Centers, Inc., [Annise Parker, Senior Vice President and Chief Strategy Officer], General Partner), and Harrisburg Blue Willow, Ltd. (Harrisburg Blue Willow GP, LLC [Linda Schmuck, President], General Partner), requested the abandonment and sale of Felix Street, from Harrisburg Street south to its terminus, located within the Harrisburg Market Subdivision out of the S.M. Williams Survey, A-87. Harrisburg Blue Willow, Ltd. plans to sell the portion abutting its property to BakerRipley following the passage of the ordinance for the subject street abandonment. BakerRipley plans to expand and develop BakerRipley as its corporate headquarters. The development will include a four-story retail building, office facility, and job skills improvement center.

BakerRipley and Harrisburg Blue Willow, Ltd. have complied with the transaction requirements, have accepted the City's offer, and have rendered payment in full.

The City will abandon and sell to BakerRipley:

**Parcel SY17-045**

4,071 square-foot right of way easement: \$117,001.00 (R)  
Valued at \$28.74 PSF x 100%

Depreciated cost of improvements \$4,511.00  
(concrete curbing and pavement)

**TOTAL ABANDONMENT: \$121,512.00 (R)**

The City will abandon and sell to Harrisburg Blue Willow, Ltd.:

**Parcel SY17-051**

4,177 square-foot right of way easement: \$120,047.00 (R)  
Valued at \$28.74 PSF x 100%

Depreciated cost of improvements \$4,400.00  
(concrete curbing and pavement)

**TOTAL ABANDONMENT: \$124,447.00 (R)**

**TOTAL ABANDONMENTS: \$245,959.00 (R)**

Therefore, it is recommended City Council approve an Ordinance authorizing the abandonment and sale of Felix Street, from Harrisburg Street south to its terminus, located within the Harrisburg Market Subdivision out of the S.M. Williams Survey, A-87

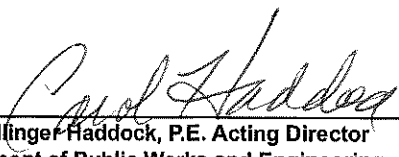

---

**Carol Ellinger Haddock, P.E. Acting Director**  
**Department of Public Works and Engineering**

**Contact Information:**

Darrin Ward  
Acting Senior Assistant Director-Real Estate Services  
(832) 395-3154

**ATTACHMENTS:**

**Description**

Council District Map  
Approved Parcel Drawing

**Type**

Backup Material  
Backup Material

Council District Map - District H

Abandonment and sale of Felix Street, from Harrisburg Street south to its terminus, located within the Harrisburg Market Subdivision. **Parcels SY17-045 and SY17-051**



1 inch = 83 feet

**CITY OF HOUSTON**  
Department of Public Works and Engineering  
Geographic Information & Management System (GIMS)



DISCLAIMER: THIS MAP REPRESENTS THE BEST INFORMATION AVAILABLE TO THE CITY.  
THE CITY DOES NOT WARRANT ITS ACCURACY OR COMPLETENESS.

**Approved Parcel Drawing - Parcels SY17-045 and SY17-051**

Abandonment and sale of Felix Street, from Harrisburg Street south to its terminus, located within the Harrisburg Market Subdivision.

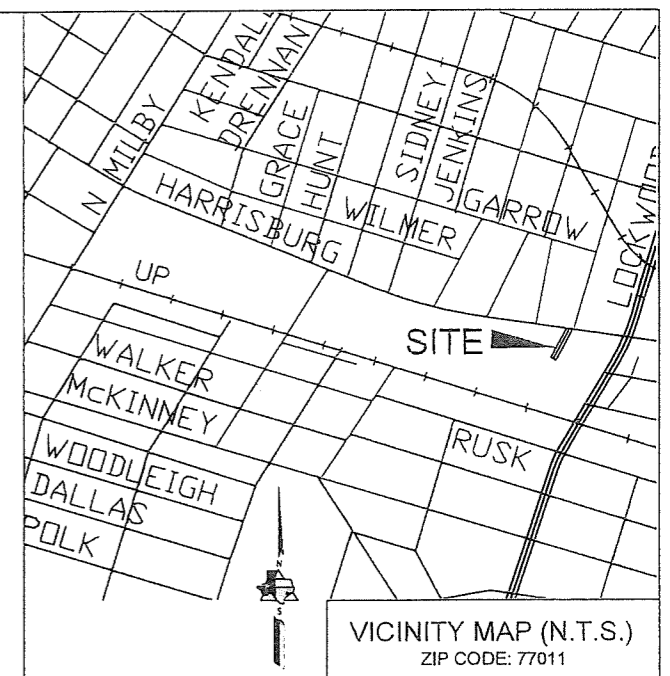
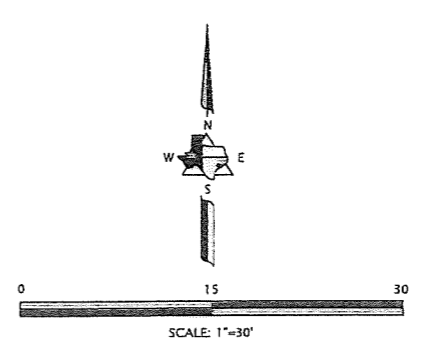
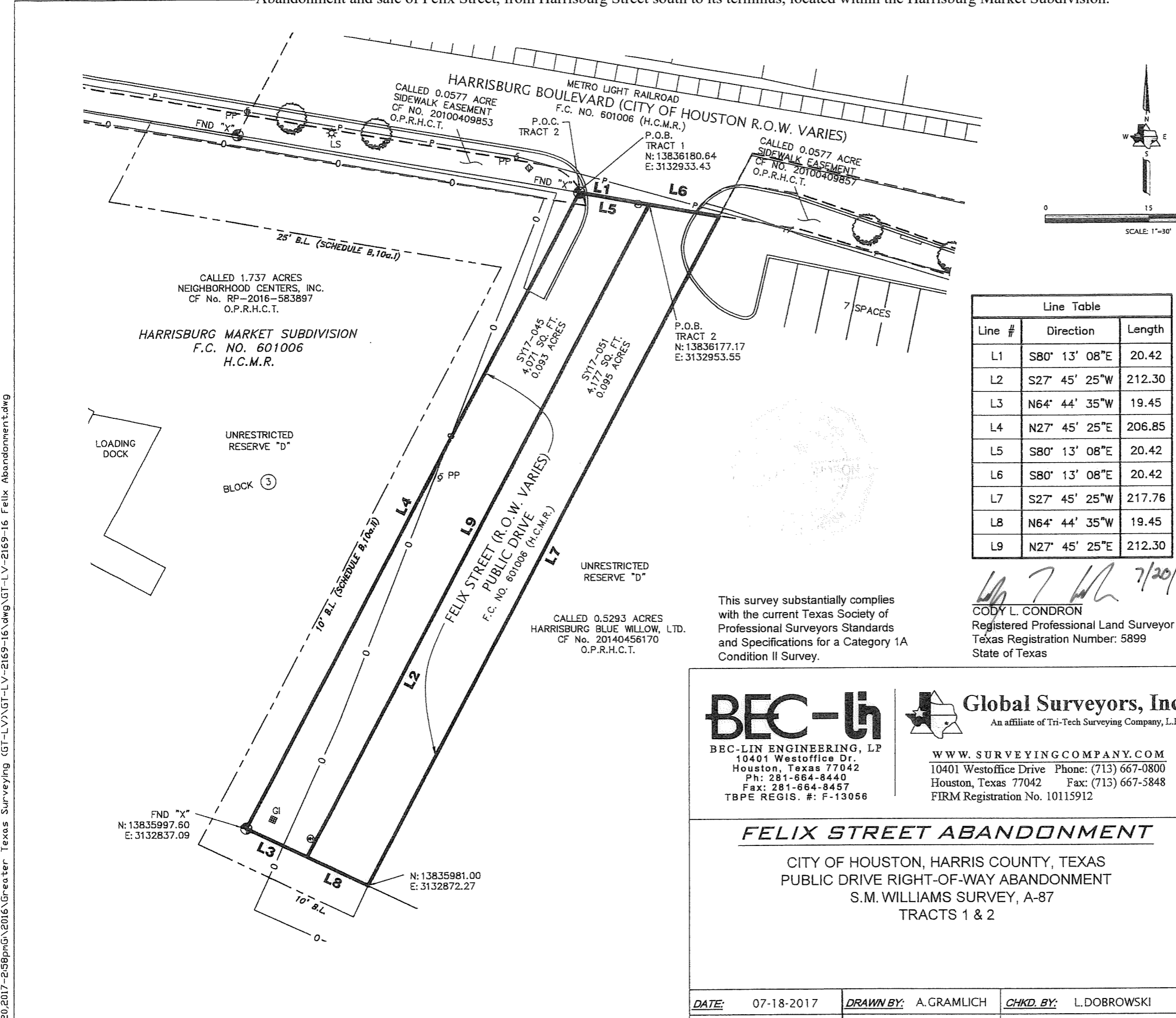

Line Table		
Line #	Direction	Length
L1	S80° 13' 08"E	20.42
L2	S27° 45' 25"W	212.30
L3	N64° 44' 35"W	19.45
L4	N27° 45' 25"E	206.85
L5	S80° 13' 08"E	20.42
L6	S80° 13' 08"E	20.42
L7	S27° 45' 25"W	217.76
L8	N64° 44' 35"W	19.45
L9	N27° 45' 25"E	212.30

**NOTES:**

1. ALL BEARINGS AND COORDINATES SHOWN HEREON ARE GRID WITH DISTANCES BEING TRUE BASED UPON TEXAS STATE PLANE COORDINATE SYSTEM SOUTH CENTRAL ZONE (4204). THE COMBINED SCALE FACTOR BETWEEN GRID AND SURFACE IS 0.99988671934.
2. SEE EXHIBIT "A" FOR METES AND BOUNDS DESCRIPTIONS (PAGES 2-3 OF 3)

This survey substantially complies with the current Texas Society of Professional Surveyors Standards and Specifications for a Category 1A Condition II Survey.

*Cody L. Condron*  
 CODY L. CONDRON  
 Registered Professional Land Surveyor  
 Texas Registration Number: 5899  
 State of Texas

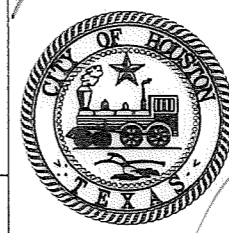

**CITY OF HOUSTON  
 PUBLIC WORKS AND  
 ENGINEERING DEPARTMENT**

APPROVAL

*[Signature]*

7/29/17  
 DATE

*[Signature]*

SURVEY SECTION

RIGHT OF WAY SECTION

KEY MAP No. 494T

GIMS MAP No. 5456b

PARCEL NOS.

SY17-045

SY17-051

JOB NO.

WBS NO.

C.M. NO.

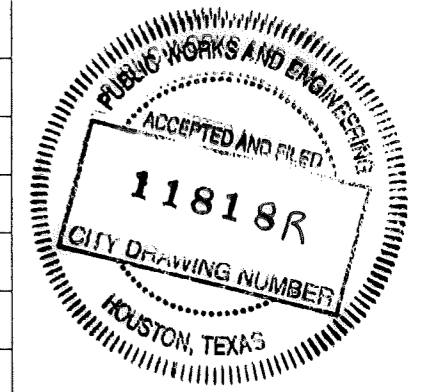

**BEC-LH**  
 BEC-LIN ENGINEERING, LP  
 10401 Westoffice Dr.  
 Houston, Texas 77042  
 Ph: 281-664-8440  
 Fax: 281-664-8457  
 TBPE REGIS. #: F-13056

**Global Surveyors, Inc.**  
 An affiliate of Tri-Tech Surveying Company, L.P.  
 www.surveyingcompany.com  
 10401 Westoffice Drive Phone: (713) 667-0800  
 Houston, Texas 77042 Fax: (713) 667-5848  
 FIRM Registration No. 10115912

<b>FELIX STREET ABANDONMENT</b>		
CITY OF HOUSTON, HARRIS COUNTY, TEXAS PUBLIC DRIVE RIGHT-OF-WAY ABANDONMENT S.M. WILLIAMS SURVEY, A-87 TRACTS 1 & 2		
DATE: 07-18-2017	DRAWN BY: A.GRAMLICH	CHKD. BY: L.DOBROWSKI
SCALE: 1" = 30'	JOB NO. GT-LV-2169-16	DWG. NAME: GT-LV-2169-16

Jul 20, 2017 - 2:58pm G:\2016\Greater Texas Surveying (GT-LV)\GT-LV-2169-16.dwg GT-LV-2169-16 Felix Abandonment.dwg



## CITY OF HOUSTON - CITY COUNCIL

Meeting Date: 11/8/2017

District E

Item Creation Date: 9/22/2017

20TP9718 Sale of Pipeline Easement to Seabrook  
Pipeline\SY17-032

Agenda Item#: 10.

### **Summary:**

ORDINANCE authorizing the sale of a 30-foot-wide subsurface pipeline easement traversing the City of Houston Southeast Water Purification Plant, located in the W.C. R.R. Co. Survey, Abstract No. 933, the William H. Anthony Survey, Abstract No. 1460, and the Day Land & Cattle Survey, Abstract No. 1042, Harris County, Texas, to Seabrook Pipeline, LLC, in consideration of its payment to the City of \$56,493.00 and other consideration - **DISTRICT E - MARTIN**

### **Background:**

**SUBJECT:** Ordinance authorizing the sale and conveyance of a 30 foot-wide subsurface pipeline easement traversing the City of Houston Southeast Water Purification Plant, Tracts 1A, 1A-1, 1B, 1C, 1D, 1E, 1F, 1G, 1H, 1J, 1K, 3A and 4C, out of the William H. Anthony Survey, A-1460, W.C. R.R. Co. Survey, A-933, and the Day Land and Cattle Company Survey, A-1042. **Parcel SY17-032**

**RECOMMENDATION:** (Summary) It is recommended City Council approve an ordinance authorizing the sale and conveyance of a 30 foot-wide subsurface pipeline easement traversing the City of Houston Southeast Water Purification Plant, Tracts 1A, 1A-1, 1B, 1C, 1D, 1E, 1F, 1G, 1H, 1J, 1K, 3A and 4C, in exchange for a consideration of \$56,493.00, out of the William H. Anthony Survey, A-1460, W.C. R.R. Co. Survey, A-933, and the Day Land and Cattle Company Survey, A-1042. **Parcel SY17-032**

### **SPECIFIC EXPLANATION:**

Keith Hogan, on behalf of Seabrook Pipeline, LLC (Magellan Pipeline GP, LLC [Michael Pearson, Vice President], General Partner) requested the sale and conveyance of a 30 foot-wide subsurface pipeline easement traversing the City of Houston Southeast Water Purification Plant, Tracts 1A, 1A-1, 1B, 1C, 1D, 1E, 1F, 1G, 1H, 1J, 1K, 3A and 4C, out of the William H. Anthony Survey, A-1460, W.C. R.R. Co. Survey, A-933, and the Day Land and Cattle Company Survey, A-1042. The applicant plans to use the requested 30 foot-wide subsurface pipeline easement for a 24-inch crude pipeline. The Joint Referral Committee reviewed and approved the request subject to receiving a no objection clearance from the Department of Public Works and Engineering-Houston Water. Seabrook Pipeline, LLC has complied with the transaction requirements, has accepted the City's offer, and has rendered payment in full.

The City sell to Seabrook Pipeline, LLC:

**Parcel SY17-032**

90,389 square-foot pipeline easement: \$56,493.00 (R)  
Valued at \$2.50 per square foot x 25%

**TOTAL SALE** **\$56,493.00 (R)**

Therefore, it is recommended City Council approve an ordinance authorizing the sale and conveyance of a 30 foot-wide subsurface pipeline easement traversing the City of Houston Southeast Water Purification Plant, Tracts 1A, 1A-1, 1B, 1C, 1D, 1E, 1F, 1G, 1H, 1J, 1K, 3A and 4C, in exchange for a consideration of \$56,493.00, out of the William H. Anthony Survey, A-1460, W.C. R.R. Co. Survey, A-933, and the Day Land and Cattle Company Survey, A-1042.

**Contact Information:**

Darrin Ward  
Acting Senior Assistant Director - Real Estate Services  
(832) 395-3154

---

Carol Ellinger Haddock, P.E., Acting Director  
Department of Public Works and Engineering

**ATTACHMENTS:**

**Description**

Signed Coversheet  
Council District Map  
Aerial Map

**Type**

Signed Cover sheet  
Backup Material  
Backup Material



**CITY OF HOUSTON - CITY COUNCIL**

Meeting Date:

District E

Item Creation Date: 9/22/2017

20TP9718\Sale of Pipeline Easement to Seabrook Pipeline\SY17-032

Agenda Item#:

**Background:**

**SUBJECT:** Ordinance authorizing the sale and conveyance of a 30 foot-wide subsurface pipeline easement traversing the City of Houston Southeast Water Purification Plant, Tracts 1A, 1A-1, 1B, 1C, 1D, 1E, 1F, 1G, 1H, 1J, 1K, 3A and 4C, out of the William H. Anthony Survey, A-1460, W.C. R.R. Co. Survey, A-933, and the Day Land and Cattle Company Survey, A-1042. Parcel SY17-032

**RECOMMENDATION:** (Summary) It is recommended City Council approve an ordinance authorizing the sale and conveyance of a 30 foot-wide subsurface pipeline easement traversing the City of Houston Southeast Water Purification Plant, Tracts 1A, 1A-1, 1B, 1C, 1D, 1E, 1F, 1G, 1H, 1J, 1K, 3A and 4C, in exchange for a consideration of \$56,493.00, out of the William H. Anthony Survey, A-1460, W.C. R.R. Co. Survey, A-933, and the Day Land and Cattle Company Survey, A-1042. Parcel SY17-032

**SPECIFIC EXPLANATION:**

Keith Hogan, on behalf of Seabrook Pipeline, LLC (Magellan Pipeline GP, LLC [Michael Pearson, Vice President], General Partner) requested the sale and conveyance of a 30 foot-wide subsurface pipeline easement traversing the City of Houston Southeast Water Purification Plant, Tracts 1A, 1A-1, 1B, 1C, 1D, 1E, 1F, 1G, 1H, 1J, 1K, 3A and 4C, out of the William H. Anthony Survey, A-1460, W.C. R.R. Co. Survey, A-933, and the Day Land and Cattle Company Survey, A-1042. The applicant plans to use the requested 30 foot-wide subsurface pipeline easement for a 24-inch crude pipeline. The Joint Referral Committee reviewed and approved the request subject to receiving a no objection clearance from the Department of Public Works and Engineering-Houston Water. Seabrook Pipeline, LLC has complied with the transaction requirements, has accepted the City's offer, and has rendered payment in full.

The City sell to Seabrook Pipeline, LLC:

**Parcel SY17-032**

90,389 square-foot pipeline easement: \$56,493.00 (R)  
Valued at \$2.50 per square foot x 25%

**TOTAL SALE \$56,493.00 (R)**

Therefore, it is recommended City Council approve an ordinance authorizing the sale and conveyance of a 30 foot-wide subsurface pipeline easement traversing the City of Houston Southeast Water Purification Plant, Tracts 1A, 1A-1, 1B, 1C, 1D, 1E, 1F, 1G, 1H, 1J, 1K, 3A and 4C, in exchange for a consideration of \$56,493.00, out of the William H. Anthony Survey, A-1460, W.C. R.R. Co. Survey, A-933, and the Day Land and Cattle Company Survey, A-1042.

**Contact Information:**

Darrin Ward  
Acting Senior Assistant Director - Real Estate Services  
(832) 395-3154

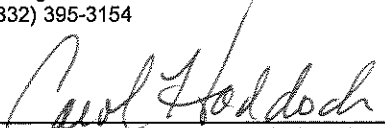
  
Carol Ellinger Haddock, P.E., Acting Director  
Department of Public Works and Engineering

**ATTACHMENTS:**

Description	Type
<a href="#">Parcel Drawing</a>	Backup Material
<a href="#">Aerial Map</a>	Backup Material
<a href="#">Council District Map</a>	Backup Material

Council District Map

Sale and conveyance of a 30 foot-wide subsurface pipeline easement traversing the City of Houston Southeast Water Purification Plant, Tracts 1A, 1A-1, 1B, 1C, 1D, 1E, 1F, 1G, 1H, 1J, 1K, 3A and 4C, out of the William H. Anthony Survey, A-1460, W.C. R.R. Co. Survey, A-933, and the Day Land and Cattle Company Survey, A-1042



Legend

2016 Council District E

City of Houston  
Council District E  
Dave Martin



0 1.55 3.1 6.2 Miles

Source: COHGIS Database  
Date: Jan 2016  
Reference: PJ18630\_e

This map is made available for reference purposes only and should not be substituted for a survey product. The City of Houston will not accept liability of any kind in conjunction with its use.



PLANNING & DEVELOPMENT DEPARTMENT

AERIAL MAP - GENOA RED BLUFF - SOUTHEAST PURIFICATION PLANT



CITY OF HOUSTON

Department of Public Works and Engineering  
Geographic Information & Management System (GIMS)

DISCLAIMER: THIS MAP REPRESENTS THE BEST INFORMATION AVAILABLE TO THE CITY.  
THE CITY DOES NOT WARRANT ITS ACCURACY OR COMPLETENESS.

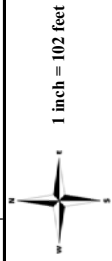



## CITY OF HOUSTON - CITY COUNCIL

Meeting Date: 11/8/2017

District I

Item Creation Date: 10/20/2017

MYR - TIRZ 15 East Downtown FY18 Budget

Agenda Item#: 11.

### **Summary:**

ORDINANCE relating to the Fiscal Affairs of the **EAST DOWNTOWN REDEVELOPMENT AUTHORITY** on behalf of **REINVESTMENT ZONE NUMBER FIFTEEN, CITY OF HOUSTON, TEXAS (EAST DOWNTOWN ZONE)**; approving the Fiscal Year 2018 Operating Budget for the Authority and the Fiscal Years 2018-2022 Capital Improvements Budget for the Zone - **DISTRICT I - GALLEGOS**

### **Background:**

**SUBJECT:** Ordinance approving the Fiscal Year 2018 Operating Budget for the East Downtown Redevelopment Authority and the Fiscal Years 2018 - 2022 Capital Improvement Plan (CIP) Budget for Reinvestment Zone Number Fifteen (East Downtown Zone).

### **RECOMMENDATION: (Summary)**

City Council to adopt an ordinance approving the Fiscal Year 2018 Operating Budget for the East Downtown Redevelopment Authority and Fiscal Years 2018 - 2022 CIP Budget for Reinvestment Zone Number Fifteen (East Downtown Zone).

### **SPECIFIC EXPLANATION:**

The Administration has undertaken a comprehensive review of the proposed FY18 TIRZ Budgets and recommends approval of the FY18 Operating Budget for the East Downtown Redevelopment Authority (the "Authority") and the FY18 – FY22 CIP Budget for Reinvestment Zone Number Fifteen (the "Zone").

- Total Operating Budget for FY18 is \$19,331,435 which includes \$1,111,788 for required fund transfers and \$18,219,647 for Project Costs.
- The FY18 – FY22 CIP totals \$29,570,396 and includes provisions for the design and reconstruction of roadway and streets, pedestrian safety improvements, mobility improvements and utility upgrades and replacements.
- The FY18 Operating Budget includes \$15,751,061 for capital expenditures and \$109,500 for administration and overhead. The Authority must advise the Chief Development Officer of any budget amendment. Adjustments to the budget in excess of \$400,000 require City

Council approval.

- The budget includes a municipal services cost payment in FY18 of \$313,726 for the incremental cost of providing services to the area.

Attachments: FY18 Operating Budget and FY18 – FY22 CIP Budget

cc:

Marta Crinejo, Agenda Director

Anna Russell, City Secretary

Ronald Lewis, City Attorney

Gary Dzierlenga, Senior Assistant City Attorney

**Prior Council Action:**

Ord. No. 2016-0644, 8/31/16

**Amount of Funding:**

No funding required

**Contact Information:**

Gwendolyn F. Tillotson

**Phone:** (832) 393-0937

**ATTACHMENTS:**

**Description**

**Type**

RCA TIRZ 15 East Downtown FY18 Budget

Signed Cover sheet

**REQUEST FOR COUNCIL ACTION**

**TO: Mayor via City Secretary**

**RCA #**

**SUBJECT:** Ordinance approving the Fiscal Year 2018 Operating Budget for the East Downtown Redevelopment Authority and the Fiscal Years 2018 - 2022 Capital Improvement Plan (CIP) Budget for Reinvestment Zone Number Fifteen (East Downtown Zone).

**Category #**

**Page**  
1 of 1

**Agenda Item#**

**FROM: (Department or other point of origin):**

Andrew F. Icken  
Chief Development Officer

**Origination Date**

**Agenda Date**

**DIRECTOR'S SIGNATURE:**



**Council Districts affected:**

1

**For additional information contact:**

Gwendolyn F. Tillotson

**Phone:** (832) 393-0937

**Date and identification of prior authorizing Council Action:**

Ord. No. 2016-0644, 8/31/16

**RECOMMENDATION: (Summary)**

City Council to adopt an ordinance approving the Fiscal Year 2018 Operating Budget for the East Downtown Redevelopment Authority and Fiscal Years 2018 - 2022 CIP Budget for Reinvestment Zone Number Fifteen (East Downtown Zone).

**Amount of Funding:** No Funding Required

**SOURCE OF FUNDING:**

General Fund     Grant Fund     Enterprise Fund  
 Other (Specify)

**SPECIFIC EXPLANATION:**

The Administration has undertaken a comprehensive review of the proposed FY18 TIRZ Budgets and recommends approval of the FY18 Operating Budget for the East Downtown Redevelopment Authority (the "Authority") and the FY18 – FY22 CIP Budget for Reinvestment Zone Number Fifteen (the "Zone").

- Total Operating Budget for FY18 is \$19,331,435 which includes \$1,111,788 for required fund transfers and \$18,219,647 for Project Costs.
- The FY18 – FY22 CIP totals \$29,570,396 and includes provisions for the design and reconstruction of roadway and streets, pedestrian safety improvements, mobility improvements and utility upgrades and replacements.
- The FY18 Operating Budget includes \$15,751,061 for capital expenditures and \$109,500 for administration and overhead. The Authority must advise the Chief Development Officer of any budget amendment. Adjustments to the budget in excess of \$400,000 require City Council approval.
- The budget includes a municipal services cost payment in FY18 of \$313,726 for the incremental cost of providing services to the area.

Attachments: FY18 Operating Budget and FY18 – FY22 CIP Budget

cc:

Marta Crinejo, Agenda Director  
Anna Russell, City Secretary  
Ronald Lewis, City Attorney  
Gary Dzierlenga, Senior Assistant City Attorney

**REQUIRED AUTHORIZATION**

**Finance Authorization:**

**Other Authorization:**

**Other Authorization:**



## CITY OF HOUSTON - CITY COUNCIL

Meeting Date: 11/8/2017

District I

Item Creation Date: 9/18/2017

PLN - Special Minimum Lot Size Block App 669 (1400  
Block of Lombardy Street, north side)

Agenda Item#: 12.

### **Summary:**

ORDINANCE establishing the north side of the **1400 block of Lombardy Street**, within the City of Houston, Texas, as a special minimum lot size block pursuant to Chapter 42 of the Code of Ordinances, Houston, Texas - **DISTRICT I - GALLEGOS**

### **Background:**

In accordance with Section 42-197 of the Code of Ordinances, the property owner of Lot 37, Block 12, of the Broadmoor Subdivision initiated an application for the designation of a Special Minimum Lot Size Block (SMLSB). The application includes written evidence of support from the owners of 42% of the block. The Planning and Development Department mailed notifications to 16 property owners indicating that the SMLSB application had been submitted. The notification further stated that written protest must be filed with the Planning and Development Department within thirty days of mailing. No protest was filed. This application had less than 51% support and was referred to the Houston Planning Commission for review and consideration. The Houston Planning Commission considered the application on September 14, 2017 and voted to recommend that the City Council establish the SMLSB.

The Planning and Development Department recommends that City Council adopt an ordinance establishing a Special Minimum Lot Size of 6,250 square feet for the 1400 block of Lombardy Street, north side.

---

Patrick Walsh, P.E.  
Director  
Planning and Development Department

### **Contact Information:**

Abraham Zorrilla  
Planner I

832.393.6634

**ATTACHMENTS:**

**Description**

RCA Cover

MAP

**Type**

Signed Cover sheet

Backup Material



## CITY OF HOUSTON - CITY COUNCIL

Meeting Date:

District I

Item Creation Date: 9/18/2017

PLN - Special Minimum Lot Size Block App 669 (1400 Block of Lombardy Street, north side)

Agenda Item#:

### **Background:**

In accordance with Section 42-197 of the Code of Ordinances, the property owner of Lot 37, Block 12, of the Broadmoor Subdivision initiated an application for the designation of a Special Minimum Lot Size Block (SMLS B). The application includes written evidence of support from the owners of 42% of the block. The Planning and Development Department mailed notifications to 16 property owners indicating that the SMLS B application had been submitted. The notification further stated that written protest must be filed with the Planning and Development Department within thirty days of mailing. No protest was filed. This application had less than 51% support and was referred to the Houston Planning Commission for review and consideration. The Houston Planning Commission considered the application on September 14, 2017 and voted to recommend that the City Council establish the SMLS B.

The Planning and Development Department recommends that City Council adopt an ordinance establishing a Special Minimum Lot Size of 6,250 square feet for the 1400 block of Lombardy Street, north side.

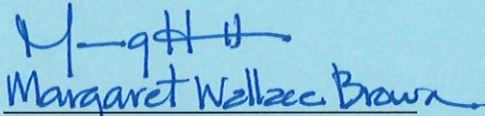
  
Margaret Wallace Brown

Patrick Walsh, P.E.

Director

Planning and Development Department

### **Contact Information:**

Abraham Zorrilla

Planner I

832.393.6634

### **ATTACHMENTS:**

**Description**

MAP

**Type**

Other

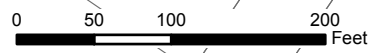
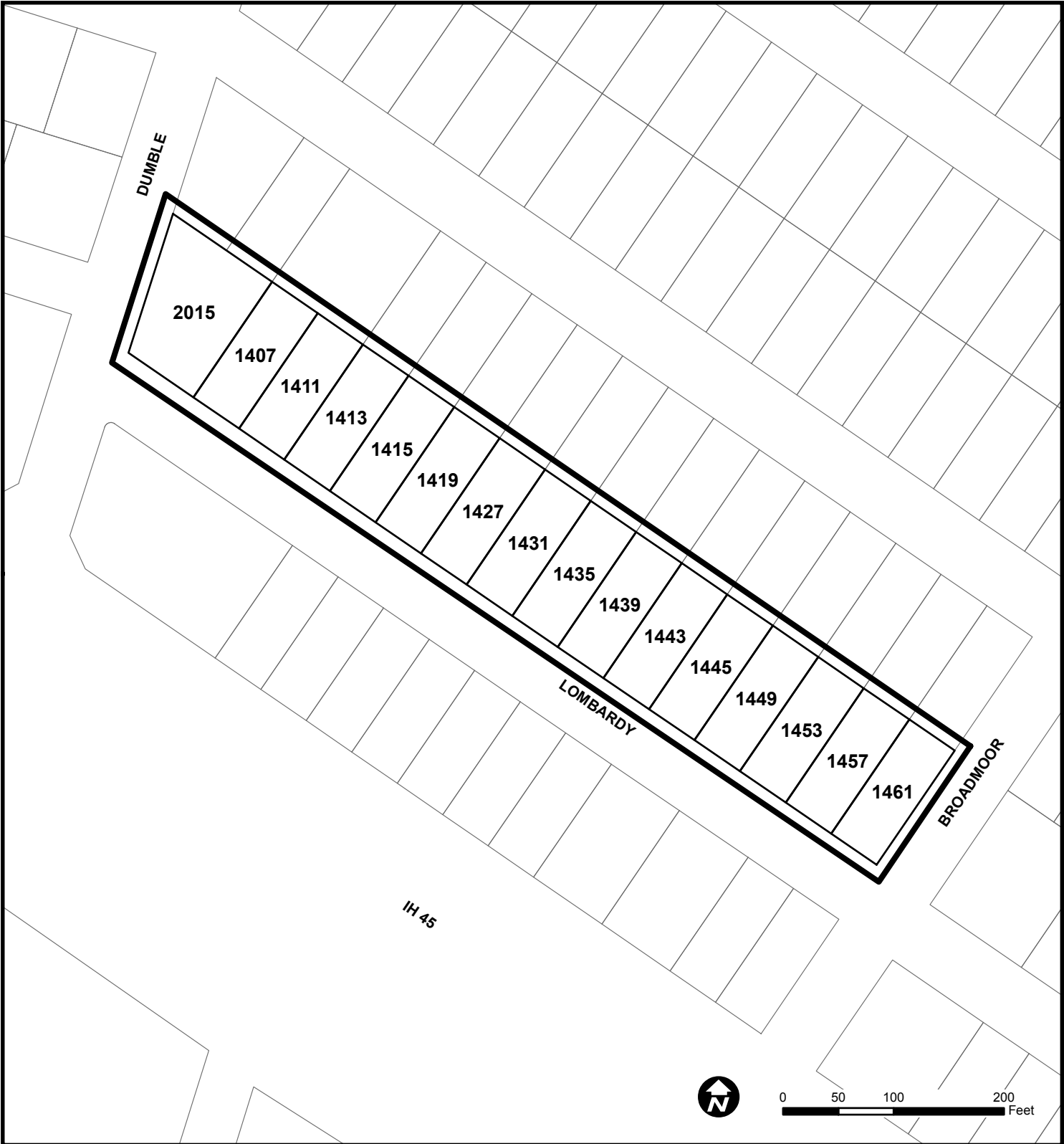

**Special Minimum Lot Size**  
**1400 Block of Lombardy Street, north side,**  
**between Dumble and Broadmoor Streets**  
**6,250 square feet**

 Area Under Consideration

Source: Harris County Appraisal District  
 Date: July 31, 2017  
 Reference: MLS 669

This map is made available for reference purposes only and should not be substituted for a survey product. The City of Houston will not accept liability of any kind in conjunction with its use.





## CITY OF HOUSTON - CITY COUNCIL

Meeting Date: 11/8/2017

District I

Item Creation Date: 8/7/2017

PLN - Special Minimum Lot Size Block App 664 (1700 -  
1800 block of Lombardy Street, east side)

Agenda Item#: 13.

### **Summary:**

ORDINANCE establishing the east side of the **1700-1800 block of Lombardy Street**, within the City of Houston, Texas, as a special minimum lot size block pursuant to Chapter 42 of the Code of Ordinances, Houston, Texas - **DISTRICT I - GALLEGOS**

### **Background:**

In accordance with Section 42-197 of the Code of Ordinances, the property owner of Lot 7, Block 9, of the Broadmoor Subdivision initiated an application for the designation of a Special Minimum Lot Size Block (SMLS B). The application includes written evidence of support from the owners of 56% of the block. The Planning and Development Department mailed notifications to sixteen (16) property owners indicating that the SMLS B application had been submitted. The notification further stated that written protest must be filed with the Planning and Development Department within thirty days of mailing. In accordance with the Code, since no protest was filed, no action was required by the Houston Planning Commission in order to submit the application to City Council.

The Planning and Development Department recommends that City Council adopt an ordinance establishing a Special Minimum Lot Size of 6,250 square feet for the 1700 and 1800 block of Lombardy Street, east side.

---

Patrick Walsh, P.E.  
Director  
Planning and Development Department

### **Contact Information:**

Abraham Zorrilla  
Planner I  
832.393.6634

### **ATTACHMENTS:**

**Description**

RCA Cover

**Type**

Signed Cover sheet



## CITY OF HOUSTON - CITY COUNCIL

Meeting Date:

District I

Item Creation Date: 8/7/2017

PLN - Special Minimum Lot Size Block App 664 (1700 - 1800 block of Lombardy Street,  
east side)

Agenda Item#:

### **Background:**

In accordance with Section 42-197 of the Code of Ordinances, the property owner of Lot 7, Block 9, of the Broadmoor Subdivision initiated an application for the designation of a Special Minimum Lot Size Block (SMLSB). The application includes written evidence of support from the owners of 56% of the block. The Planning and Development Department mailed notifications to sixteen (16) property owners indicating that the SMLSB application had been submitted. The notification further stated that written protest must be filed with the Planning and Development Department within thirty days of mailing. In accordance with the Code, since no protest was filed, no action was required by the Houston Planning Commission in order to submit the application to City Council.

The Planning and Development Department recommends that City Council adopt an ordinance establishing a Special Minimum Lot Size of 6,250 square feet for the 1700 and 1800 block of Lombardy Street, east side.

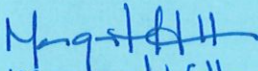
  
Margaret Wallace Brown for

Patrick Walsh, P.E.

Director

Planning and Development Department

### **Contact Information:**

Abraham Zorrilla

Planner I

832.393.6634

### **ATTACHMENTS:**

**Description**

MAP

**Type**

Other



## CITY OF HOUSTON - CITY COUNCIL

Meeting Date: 11/8/2017

District C

Item Creation Date: 9/13/2017

PLN - Special Minimum Lot Size Block App 660 (2200  
Block of McClendon Street, north and south sides)

Agenda Item#: 14.

### **Summary:**

ORDINANCE establishing the north and south sides of the **2200 block of McClendon Street**, within the City of Houston, Texas, as a special minimum lot size block pursuant to Chapter 42 of the Code of Ordinances, Houston, Texas - **DISTRICT C - COHEN**

### **Background:**

In accordance with Section 42-197 of the Code of Ordinances, the property owner of Lot 9, Block 5, of the Southgate Subdivision, Section 3, initiated an application for the designation of a Special Minimum Lot Size Block (SMLSB). The application includes written evidence of support from the owners of 65% of the block. The Planning and Development Department mailed notifications to 19 property owners indicating that the SMLSB application had been submitted. The notification further stated that written protest must be filed with the Planning and Development Department within thirty days of mailing. In accordance with the Code, since no protest was filed, no action was required by the Houston Planning Commission in order to submit the application to City Council.

The Planning and Development Department recommends that City Council adopt an ordinance establishing a Special Minimum Lot Size of 7,744 square feet for the 2200 block of McClendon Street, north and south sides.

---

Patrick Walsh, P.E.  
Director  
Planning and Development Department

### **Prior Council Action:**

N/A

### **Amount of Funding:**

N/A

### **Contact Information:**

Christopher Andrews (832) 393-6520

**ATTACHMENTS:**

**Description**

Signed RCA Cover Sheet  
MLS 660 Map

**Type**

Signed Cover sheet  
Backup Material



**CITY OF HOUSTON - CITY COUNCIL**

Meeting Date:

District C

Item Creation Date: 9/13/2017

PLN - Special Minimum Lot Size Block App 660 (2200 Block of McClendon Street, north and south sides)

Agenda Item#:

**Summary:**

**Background:**

In accordance with Section 42-197 of the Code of Ordinances, the property owner of Lot 9, Block 5, of the Southgate Subdivision, Section 3, initiated an application for the designation of a Special Minimum Lot Size Block (SMLS Block). The application includes written evidence of support from the owners of 65% of the block. The Planning and Development Department mailed notifications to 19 property owners indicating that the SMLS Block application had been submitted. The notification further stated that written protest must be filed with the Planning and Development Department within thirty days of mailing. In accordance with the Code, since no protest was filed, no action was required by the Houston Planning Commission in order to submit the application to City Council.

The Planning and Development Department recommends that City Council adopt an ordinance establishing a Special Minimum Lot Size of 7,744 square feet for the 2200 block of McClendon Street, north and south sides.

  
Margaret Wallace Brown for

Patrick Walsh, P.E.  
Director  
Planning and Development Department

**Prior Council Action:**

N/A

**Amount of Funding:**

N/A

**Contact Information:**

Christopher Andrews (832) 393-6520

**ATTACHMENTS:**

Description	Type
MLS 660 Map	Backup Material



**Special Minimum Lot Size**  
**2200 block of McClendon Street,**  
**North side between Greenbriar Drive and Montclair Drive,**  
**South side between Bellgreen Drive and Montclair Drive**  
**7,744 Square Feet**

Source: Harris County Appraisal District  
 Date: June 8, 2017  
 Reference: MLS 660

This map is made available for reference purposes only and should not be substituted for a survey product. The City of Houston will not accept liability of any kind in conjunction with its use.

 Special Minimum Lot Size Boundary



**PLANNING &  
 DEVELOPMENT  
 DEPARTMENT**



## CITY OF HOUSTON - CITY COUNCIL

Meeting Date: 11/8/2017

District D

Item Creation Date: 9/5/2017

PLN – Special Minimum Lot Size Area App 651 - North  
MacGregor Oaks & Timber Crest Subdivisions

Agenda Item#: 15.

### **Summary:**

ORDINANCE establishing certain areas known as **North MacGregor Oaks Subdivision and Timber Crest Subdivision**, within the City of Houston, as special minimum lot size areas pursuant to Chapter 42 of the Code of Ordinances, Houston, Texas - **DISTRICT D - BOYKINS**

### **Background:**

In accordance with Section 42-197 of the Code of Ordinances, the property owner of Lot 4, Block 4 of the North MacGregor Oaks Subdivision initiated an application for the designation of a Special Minimum Lot Size Area (SMLSA). The application includes a petition signed from the owners of 12% of the area. There are fifty (50) properties included in the application, however, one (1) lot owned by a government agency was excluded from the response form process. The Planning and Development Department mailed response forms to forty-nine (49) property owners indicating that the SMLSA application had been submitted. The mailing further stated that their response on the form must be filed with the Planning and Development Department within thirty days of mailing. The Department received response forms signed by owners of 61% of the SMLSA in support of the designated proposed area. The Houston Planning Commission considered the application on August 24, 2017 and voted to recommend that the City Council establish the SMLSA.

The Planning and Development Department recommends that City Council adopt an ordinance establishing a Special Minimum Lot Size of 18,990 square feet on fifty (50) lots in portions of the North MacGregor Oaks and Timbercrest Subdivisions.

---

Patrick Walsh, P.E.  
Director  
Planning and Development Department

**Contact Information:**

Annette Mitchell  
Phone: (832) 393-6563

**ATTACHMENTS:**

**Description**

signed cover sheet  
Map

**Type**

Signed Cover sheet  
Backup Material



**CITY OF HOUSTON - CITY COUNCIL**

Meeting Date:

District D

Item Creation Date: 9/5/2017

PLN – Special Minimum Lot Size Area App 651 (North MacGregor Oaks Subdivision, Block 3, Lots 14-16, 19-20, TRS 17, 17A, 17A-1, 18, 18A, 21, 21A; North MacGregor Oaks Subdivision, Block 4, Lots 4-8, TRS 3, 3A, 3B, 3C, 3D, 9-12; Timber Crest Subdivision, Block 1, Lot 1, 3, TR 2; Timber Crest Subdivision, Block 7, Lots 1-15, 17, 19-23, 25-28, TRS 16, 16A, 18, 18A, 24, 24A, 26, 27, 28; ABST 75 H Tierwester, TR 3A, 3A-1, 3A-2, 3B, 3C, 3D)

Agenda Item#:

**Background:**

In accordance with Section 42-197 of the Code of Ordinances, the property owner of Lot 4, Block 4 of the North MacGregor Oaks Subdivision initiated an application for the designation of a Special Minimum Lot Size Area (SMLSA). The application includes a petition signed from the owners of 12% of the area. There are fifty (50) properties included in the application, however, one (1) lot owned by a government agency was excluded from the response form process. The Planning and Development Department mailed response forms to forty-nine (49) property owners indicating that the SMLSA application had been submitted. The mailing further stated that their response on the form must be filed with the Planning and Development Department within thirty days of mailing. The Department received response forms signed by owners of 61% of the SMLSA in support of the designated proposed area. The Houston Planning Commission considered the application on August 24, 2017 and voted to recommend that the City Council establish the SMLSA.

The Planning and Development Department recommends that City Council adopt an ordinance establishing a Special Minimum Lot Size of 18,990 square feet on fifty (50) lots in portions of the North MacGregor Oaks and Timbercrest Subdivisions.

*Margaret Wallace Bawa*

*M-Walsh for*

Patrick Walsh, P.E.  
Director  
Planning and Development Department

**Contact Information:**

Annette Mitchell  
Phone: (832) 393-6563

**ATTACHMENTS:**

Description	Type
Map	Backup Material





## CITY OF HOUSTON - CITY COUNCIL

Meeting Date: 11/8/2017

District B

Item Creation Date: 8/23/2017

PLN - Special Minimum Lot Size Block App No. 661 (5200  
block of Sue Marie Lane, east and west sides)

Agenda Item#: 16.

### **Summary:**

ORDINANCE establishing the east and west sides of the **5200 block of Sue Marie Lane**, within the City of Houston, Texas, as a special minimum lot size block pursuant to Chapter 42 of the Code of Ordinances, Houston, Texas - **DISTRICT B - DAVIS**

### **Background:**

In accordance with Section 42-197 of the Code of Ordinances, the property owner of Tract 2A, Block 1, of the Pine Forest Subdivision initiated an application for the designation of a Special Minimum Lot Size Block (SMLSB). The application includes written evidence of support from the owners of 56% of the block. The Planning and Development Department mailed notifications to twenty-two (22) property owners indicating that the SMLSB application had been submitted. The notification further stated that written protest must be filed with the Planning and Development Department within thirty days of mailing. One (1) protest was filed. The Houston Planning Commission considered the protest on August 10, 2017 and voted to recommend that the City Council establish the SMLSB.

The Planning and Development Department recommends that City Council adopt an ordinance establishing a Special Minimum Lot Size of 21,850 square feet for the 5200 block of Sue Marie Lane, east and west sides.

---

Patrick Walsh, P.E.  
Director  
Planning and Development Department

### **Contact Information:**

Annette Mitchell  
Phone: (832) 393-6563

**ATTACHMENTS:**

**Description**

cover sheet

**Type**

Signed Cover sheet



**CITY OF HOUSTON - CITY COUNCIL**

Meeting Date:

District B

Item Creation Date: 8/23/2017

PLN - Special Minimum Lot Size Block App No. 661 (5200 block of Sue Marie Lane, east and west sides)

Agenda Item#:

**Background:**

In accordance with Section 42-197 of the Code of Ordinances, the property owner of Tract 2A, Block 1, of the Pine Forest Subdivision initiated an application for the designation of a Special Minimum Lot Size Block (SMLSB). The application includes written evidence of support from the owners of 56% of the block. The Planning and Development Department mailed notifications to twenty-two (22) property owners indicating that the SMLSB application had been submitted. The notification further stated that written protest must be filed with the Planning and Development Department within thirty days of mailing. One (1) protest was filed. The Houston Planning Commission considered the protest on August 10, 2017 and voted to recommend that the City Council establish the SMLSB.

The Planning and Development Department recommends that City Council adopt an ordinance establishing a Special Minimum Lot Size of 21,850 square feet for the 5200 block of Sue Marie Lane, east and west sides.

Patrick Walsh, P.E.

Director

Planning and Development Department

**Contact Information:**

Annette Mitchell

Phone: (832) 393-6563

**ATTACHMENTS:**

**Description**

Map

**Type**

Backup Material



## CITY OF HOUSTON - CITY COUNCIL

Meeting Date: 11/8/2017

District B

Item Creation Date: 9/21/2017

20PSK05 Payment of Certain Contract Funds / Times  
Construction, Inc.

Agenda Item#: 17.

### **Summary:**

ORDINANCE approving payment of \$11,432.38 to **TIMES CONSTRUCTION, INC** under contract with the City for Concrete Channel at 10418 Raymondville Road at Charles Street authorized by Ordinance No. 2015-0624 - **DISTRICT B - DAVIS**

### **Background:**

**SUBJECT:** Adopt an Ordinance approving payment of certain contract funds for Concrete Channel at 10418 Raymondville Road at Charles Street; WBS No. M-420126-0091-4

**RECOMMENDATION: (SUMMARY)** Adopt an Ordinance approving payment of certain contract funds in the amount of \$11,432.38 to Times Construction, Inc. for Concrete Channel at 10418 Raymondville Road at Charles Street.

**PROJECT NOTICE/JUSTIFICATION:** This project was part of the Capital Improvement Plan and was required to repair areas of structural failure in the existing concrete channel. The repairs to the concrete channel re-established the original designed capacity of the channel to convey storm water and local drainage to Halls Bayou.

**DESCRIPTION/SCOPE:** The project consisted of the construction of a low flow concrete channel which included steel piling sheet walls and concrete slope paving, drainage inlets, storm sewers, concrete headwall construction, asphalt paving, asphalt pavement milling and structure repair, asphalt paving overlay and the cleaning of an existing 84-inch diameter storm sewer. SES Horizons Consulting Engineers, Inc. designed the project with 270 calendar days allowed for construction. The project was awarded to Times Construction, Inc. with an original Contract amount of \$1,686,523.00.

**LOCATION:** This project is located in Council District B. The project area is generally bounded by Raymondville Road to the west, HCFCD P118-00-00 (Halls Bayou) to the east, Moreau Street Liberty to the north and Charles Street to the south. The project is located in Key Map Grid 414W.

**CONTRACT COMPLETION AND COST:** The Contractor, Times Construction, Inc., last performed work under the Contract on November 17, 2016, a date beyond the Original Contract time but within an additional 179 days approved by Change Order Nos. 2 through 5. No further work by the Contractor is contemplated. The Contractor could not proceed with construction of the Concrete Channel due to issues related to sheet pile movement. The project was suspended for 75 days, until January 31, 2017, in accordance with Document 00700-General Conditions, Article

14.3. Due to the length of time anticipated to finalize a design to address the sheet pile movement, Capital Projects has recommended termination of the Contract. The remainder of the Work will be performed under a different Contract due to insufficient funds in this Contract. The City issued a Notice of Termination for Convenience, effective January 31, 2017 in accordance with Article 14.2 of the Document 00700-General Conditions. The final cost of the project with previously approved Change Order Nos. 1 through 5 is \$1,143,237.76. Money remains encumbered under the Contract. This recommended action will authorize the Department of Public Works and Engineering to administratively close this Contract and to pay the net amount of \$11,432.38, the remaining 1% retainage held by the City to the Contractor.

The City notified Contractor of the City's intent to terminate the project for convenience by letter dated 03/30/2017.

City Council's approval will allow the Department of Public Works and Engineering to make all payments due to the Contractor, without any further action or stipulation by the Contractor.

**M/WSBE PARTICIPATION:** The advertised M/WBE contract goal for this project was 18.00%. The M/WSBE plan established for this project was 18.14%. According to the Office of Business Opportunity, the participation was 9.06%. Contractor's M/WSBE performance evaluation was rated Satisfactory based on their good faith efforts. The City cancelled the project for convenience before the Contractor could provide an opportunity for the subs to meet the originally listed goal for this project.

---

Carol Ellinger Haddock, P.E., Acting Director  
Department of Public Works and Engineering

WBS No. M-420126-0091-4

**Prior Council Action:**

Ordinance 2015-0624, dated 06/24/2015

**Amount of Funding:**

No additional funding required.

Total (original) appropriation of \$1,945,771.00 from Fund No. 4042 – Street & Traffic Control and Storm Drainage DDSRF.

**Contact Information:**

Brian Alcott, P.E., CCM  
Acting Senior Assistant Director, Capital Projects  
Phone: (832) 395-2396

**ATTACHMENTS:**

**Description**

Signed Coversheet  
Map

**Type**

Signed Cover sheet  
Backup Material



## CITY OF HOUSTON - CITY COUNCIL

Meeting Date:

District B

Item Creation Date: 9/21/2017

20PSK05 Payment of Certain Contract Funds / Times Construction, Inc.

Agenda Item#:

### **Background:**

**SUBJECT:** Adopt an Ordinance approving payment of certain contract funds for Concrete Channel at 10418 Raymondville Road at Charles Street; WBS No. M-420126-0091-4

**RECOMMENDATION: (SUMMARY)** Adopt an Ordinance approving payment of certain contract funds in the amount of \$11,432.38 to Times Construction, Inc. for Concrete Channel at 10418 Raymondville Road at Charles Street.

**PROJECT NOTICE/JUSTIFICATION:** This project was part of the Capital Improvement Plan and was required to repair areas of structural failure in the existing concrete channel. The repairs to the concrete channel re-established the original designed capacity of the channel to convey storm water and local drainage to Halls Bayou.

**DESCRIPTION/SCOPE:** The project consisted of the construction of a low flow concrete channel which included steel piling sheet walls and concrete slope paving, drainage inlets, storm sewers, concrete headwall construction, asphalt paving, asphalt pavement milling and structure repair, asphalt paving overlay and the cleaning of an existing 84-inch diameter storm sewer. SES Horizons Consulting Engineers, Inc. designed the project with 270 calendar days allowed for construction. The project was awarded to Times Construction, Inc. with an original Contract amount of \$1,686,523.00.

**LOCATION:** This project is located in Council District B. The project area is generally bounded by Raymondville Road to the west, HCFCD P118-00-00 (Halls Bayou) to the east, Moreau Street Liberty to the north and Charles Street to the south. The project is located in Key Map Grid 414W.

**CONTRACT COMPLETION AND COST:** The Contractor, Times Construction, Inc., last performed work under the Contract on November 17, 2016, a date beyond the Original Contract time but within an additional 179 days approved by Change Order Nos. 2 through 5. No further work by the Contractor is contemplated. The Contractor could not proceed with construction of the Concrete Channel due to issues related to sheet pile movement. The project was suspended for 75 days, until January 31, 2017, in accordance with Document 00700-General Conditions, Article 14.3. Due to the length of time anticipated to finalize a design to address the sheet pile movement, Capital Projects has recommended termination of the Contract. The remainder of the Work will be performed under a different Contract due to insufficient funds in this Contract. The City issued a Notice of Termination for Convenience, effective January 31, 2017 in accordance with Article 14.2 of the Document 00700-General Conditions. The final cost of the project with previously approved Change Order Nos. 1 through 5 is \$1,143,237.76. Money remains encumbered under the Contract. This recommended action will authorize the Department of Public Works and Engineering to administratively close this Contract and to pay the net amount of \$11,432.38, the remaining 1% retainage held by the City to the Contractor.

The City notified Contractor of the City's intent to terminate the project for convenience by letter dated 03/30/2017.

City Council's approval will allow the Department of Public Works and Engineering to make all payments due to the Contractor, without any further action or stipulation by the Contractor.

**M/WSBE PARTICIPATION:** The advertised M/WBE contract goal for this project was 18.00%. The M/WSBE plan established for this project was 18.14%. According to the Office of Business Opportunity, the participation was 9.06%. Contractor's M/WSBE performance evaluation was rated Satisfactory based on their good faith efforts. The City cancelled the project for convenience before the Contractor could provide an opportunity for the subs to meet the originally listed goal for this project.

  
Carol Ellinger Haddock, P.E., Acting Director  
Department of Public Works and Engineering

WBS No. M-420126-0091-4

### **Prior Council Action:**

Ordinance 2015-0624, dated 06/24/2015

**Amount of Funding:**

No additional funding required.

Total (original) appropriation of \$1,945,771.00 from Fund No. 4042 – Street & Traffic Control and Storm Drainage DDSRF.

**Contact Information:**

Brian Alcott, P.E., CCM  
Acting Senior Assistant Director, Capital Projects  
Phone: (832) 395-2396

**ATTACHMENTS:**

<b>Description</b>	<b>Type</b>
Map	Backup Material
OBO	Backup Material
Affidavit of Ownership	Backup Material
Tax Report	Backup Material
Prior Council Action	Backup Material
Change Orders 1-5	Backup Material

CONCRETE CHANNEL AT 10418 RAYMONDVILLE RD  
 AT CHARLES RD  
 WBS NO. M-000126-0078-4

Revised Council Districts

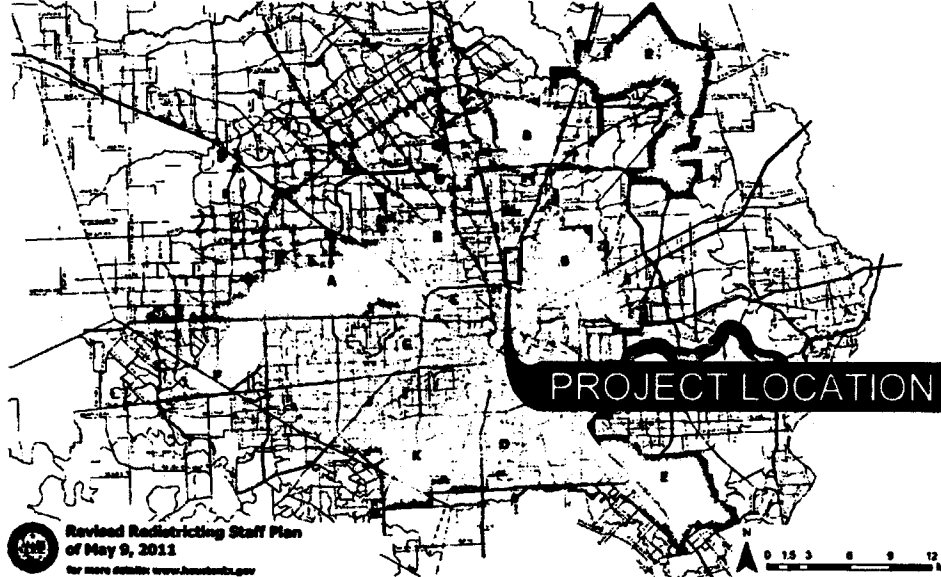

VICINITY MAP

N.T.S.

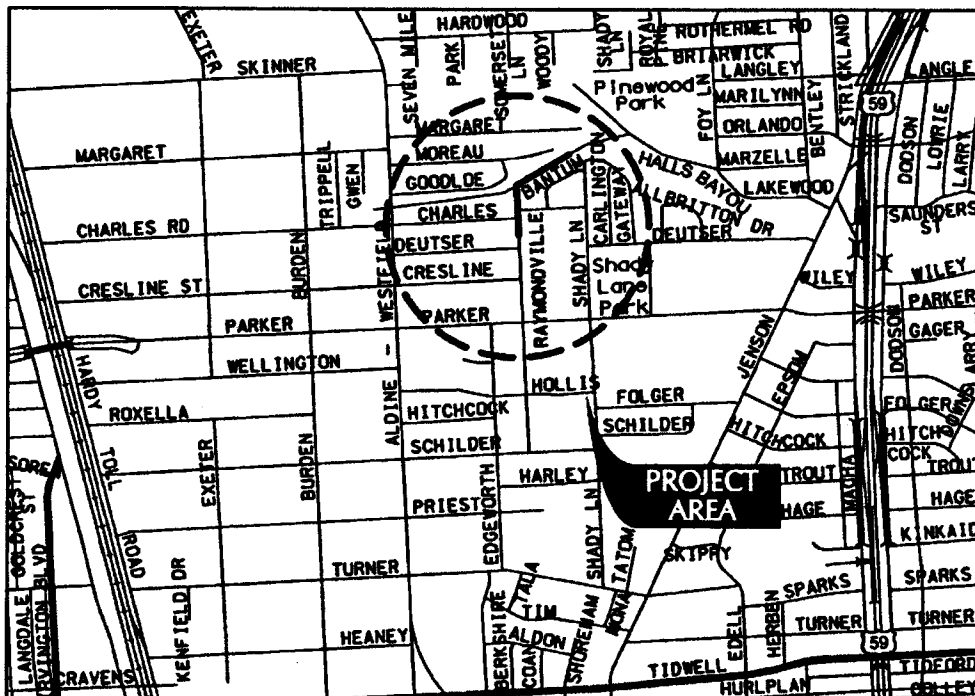

VICINITY MAP

KEY MAP NO. 414W  
 GIMS MAP NO. 5461A  
 COUNCIL DISTRICT B



## CITY OF HOUSTON - CITY COUNCIL

Meeting Date: 11/8/2017

ALL

Item Creation Date:

25MSCL125 Appropriate Funds Project Management  
Costs FY18 Capital Improvement Plan (CIP) Projects

Agenda Item#: 18.

### **Summary:**

ORDINANCE appropriating \$443,000.00 out of Fire Consolidated Construction Fund; \$748,000.00 out of Parks Consolidated Construction Fund; \$135,000.00 out of Solid Waste Consolidated Construction Fund; \$653,000.00 out of Police Consolidated Construction Fund; \$352,000.00 out of Public Library Consolidated Construction Fund; \$266,000.00 out of Public Health Consolidated Construction Fund; and \$623,000.00 out of General Improvement Consolidated Construction fund for reimbursement project management costs for FY18 Capital Improvement Plan (CIP) Projects for City departments

### **Background:**

**Specific Explanation:** The General Services Department (GSD) recommends that City Council appropriate \$3,220,000 to the CIP Project Cost Recovery Fund (Fund 1001) to cover reimbursable project management costs for FY18 CIP projects, managed by GSD, for the City departments listed below.

The requested appropriation will reimburse the CIP Project Cost Recovery Fund for the actual cost of project management services provided by architects, engineers, project managers and administrators. These employees provide labor and expertise to manage the design and construction of capital improvement projects and associated contracts. Project management costs are derived from timesheets and salary rates, along with FY18 projections.

**CIP FISCAL NOTE:** There is no estimated impact to the operating and maintenance costs as a result of this CIP salary recovery expenditure. Therefore, no Fiscal Note is required as stated in the Financial Policy Ordinance No. 2014-1078.

**Capital Project Information:** See each attached Form A for a breakdown of capital costs.

### **Amount of Funding:**

\$ 443,000	Fire Consolidated Construction Fund (4500)
\$ 748,000	Parks Consolidated Construction Fund (4502)
\$ 135,000	Solid Waste Consolidated Construction Fund (4503)
\$ 653,000	Police Consolidated Construction Fund (4504)
\$ 352,000	Public Library Consolidated Construction Fund (4507)

\$ 266,000	Public Health Consolidated Construction Fund (4508)
<u>\$ 623,000</u>	General Improvement Consolidated Construction Fund
<b>\$3,220,000</b>	<b>Total Appropriation</b>

**Contact Information:**

Jacquelyn L. Nisby

**Phone:** 832-393-8023

**ATTACHMENTS:**

**Description**

**Type**



## CITY OF HOUSTON - CITY COUNCIL

Meeting Date: 11/8/2017

ALL

Item Creation Date: 5/25/2017

20PL04 Amendment / Jones & Carter, Inc.

Agenda Item#: 19.

### **Summary:**

ORDINANCE appropriating \$600,000.00 out of Street and Traffic Control and Storm Drainage DDSRF as an additional appropriation; approving and authorizing first amendment to Professional Engineering Services Contract between the City of Houston and **JONES & CARTER, INC** for FY16 Mitigation Program for Capital Improvement Projects (Approved by Ordinance No. 2016-0095); providing funding for CIP Cost Recovery relating to construction of facilities financed by the Street & Traffic Control and Storm Drainage DDSRF

### **Background:**

**SUBJECT:** First Amendment to Professional Engineering Services Contract between the City and Jones & Carter, Inc. for FY16 Mitigation Program for Capital Improvement Program (CIP) Projects. - WBS No. M-430296-0011-3.

### **RECOMMENDATION:** (SUMMARY)

Approve First Amendment to the Professional Engineering Services Contract with Jones & Carter, Inc. and appropriate funds.

**PROJECT NOTICE/JUSTIFICATION:** This project is part of the Capital Improvement Plan. This project is required to provide regional/sub-regional detention as part of storm water drainage system improvements citywide.

**DESCRIPTION/SCOPE:** This project provides professional engineering services to design and construct regional/sub-regional detention basins to mitigate the hydraulic impact of increased storm water run-off from drainage improvement projects into receiving storm sewer systems, ditches, channels, and bayous.

**LOCATION:** The project location, limits, and scope of work will be established and defined by each work order.

**PREVIOUS HISTORY AND SCOPE:** The original contract performed Basic and Additional services for three Rehab Basins. Additional funds are needed for performing similar tasks on additional basins City Council approved the original Contract on January 25, 2016 under Ordinance No. 2016-0095. The scope of services under the Original Contract consisted of Phase II and Phase III services for the following Work Orders (WO):

- Eureka Corridor Detention Basin (WO 1)

- Ladera Canyon Detention Basin (WO 1)
- ParkSedge Detention Facility (WO 2)
- Rodeo Ditch Retention Pond (WO 3)

Various locations citywide, specific project location and limits will be established by each work order.

**SCOPE OF THIS AMENDMENT AND FEE:** Under the scope of the First Amendment, the Engineer will accomplish the following tasks: Phase II – Final Design including Basic and Additional services and Phase III – Construction Phase Services including Basic and Additional services as defined by each work order. The requested amendment to this contract is to extend contract terms to two years. All these services will be paid on a reimbursable basis with authorization not-to-exceed the agreed upon amount.

The total requested appropriation is \$600,000.00 to be appropriated as follows: \$500,000.00 for contract services and \$100,000.00 for CIP Cost Recovery.

**PAY OR PLAY PROGRAM:** The proposed contract requires compliance with the City's 'Pay or Play' ordinance regarding health benefits for employees of City contractors. In this case, the Contractor provides health benefits to eligible employees in compliance with City policy.

**M/WBE PARTICIPATION:** The M/WBE goal established for this project is 24%. The original Contract amount totals \$1,120,000.00. The Consultant has been paid \$62,648.63 (5.59) % to date. Of this amount, \$44,919.00 (71.70) % has been paid to M/WBE sub-consultants to date. Assuming approval of the requested additional appropriation, the contract amount will increase to \$1,620,000.00. The Consultant proposes the following plan to meet the M/WBE goal.

<u>Name of Firms</u>	<u>Work Description</u>	<u>Amount</u>	<u>% of Total Contract</u>
Paid Prior M/WBE Commitment		\$ 44,919.00	2.77%
Unpaid Prior M/WBE Commitment		\$ 8,189.64	0.51%
1. Geotest Engineering, Inc.	Geotechnical Service	\$ 16,000.00	0.99%
2. B&E Reprographics, Inc.	Reproduction Service	\$ 2,879.36	0.18%
3. Crouch Environmental Services, Inc.	Environmental Engineering Service	\$ 12,000.00	0.74%
4. Midtown Engineers, LLC	Engineering Service	\$127,356.00	7.86%
5. GeoSurv, Inc. DBA TSC Surveying	Surveying Service	<u>\$180,000.00</u>	<u>11.11%</u>
<b>TOTAL</b>		<b>\$391,344.00</b>	<b>24.16%</b>

**ESTIMATED FISCAL OPERATING IMPACT:**

No significant Fiscal Operating impact is anticipated as a result of this project.

---

Carol Ellinger Haddock, P.E.

Acting Director  
Department of Public Works and Engineering

WBS No. M-430296-0011-3

**Prior Council Action:**

Ordinance 2016-0095, dated 01-27-2016

**Amount of Funding:**

**Total \$600,000.00** - Fund No. 4042–Street & Traffic Control and Storm Drainage DDSRF  
(\$600,000.00 Supported by Drainage Fee)

Original (previous) appropriation of \$1,300,000.00 from Fund No. 4042 – Street & Traffic Control and Storm Drainage (DDSRF)

**Contact Information:**

Brian Alcott, P.E.  
Acting Senior Assistant Director, Capital Projects  
Phone: (832) 395-2396

**ATTACHMENTS:**

**Description**

Signed Coversheet  
Maps

**Type**

Signed Cover sheet  
Backup Material



**CITY OF HOUSTON - CITY COUNCIL**

Meeting Date:

ALL

Item Creation Date: 5/25/2017

20PL04 Amendment / Jones & Carter, Inc.

Agenda Item#:

**Background:**

**SUBJECT:** First Amendment to Professional Engineering Services Contract between the City and Jones & Carter, Inc. for FY16 Mitigation Program for Capital Improvement Program (CIP) Projects. - WBS No. M-430296-0011-3.

**RECOMMENDATION:** (SUMMARY)

Approve First Amendment to the Professional Engineering Services Contract with Jones & Carter, Inc. and appropriate funds.

**PROJECT NOTICE/JUSTIFICATION:** This project is part of the Capital Improvement Plan. This project is required to provide regional/sub-regional detention as part of storm water drainage system improvements citywide.

**DESCRIPTION/SCOPE:** This project provides professional engineering services to design and construct regional/sub-regional detention basins to mitigate the hydraulic impact of increased storm water run-off from drainage improvement projects into receiving storm sewer systems, ditches, channels, and bayous.

**LOCATION:** The project location, limits, and scope of work will be established and defined by each work order.

**PREVIOUS HISTORY AND SCOPE:** The original contract performed Basic and Additional services for three Rehab Basins. Additional funds are needed for performing similar tasks on additional basins City Council approved the original Contract on January 25, 2016 under Ordinance No. 2016-0095. The scope of services under the Original Contract consisted of Phase II and Phase III services for the following Work Orders (WO):

- Eureka Corridor Detention Basin (WO 1)
- ParkSedge Detention Facility (WO 2)
- Rodeo Ditch Retention Pond (WO 3)

Various locations citywide, specific project location and limits will be established by each work order.

**SCOPE OF THIS AMENDMENT AND FEE:** Under the scope of the First Amendment, the Engineer will accomplish the following tasks: Phase II – Final Design including Basic and Additional services and Phase III – Construction Phase Services including Basic and Additional services as defined by each work order. The requested amendment to this contract is to extend contract terms to two years. All these services will be paid on a reimbursable basis with authorization not-to-exceed the agreed upon amount.

The total requested appropriation is \$600,000.00 to be appropriated as follows: \$500,000.00 for contract services and \$100,000.00 for CIP Cost Recovery.

**PAY OR PLAY PROGRAM:** The proposed contract requires compliance with the City's 'Pay or Play' ordinance regarding health benefits for employees of City contractors. In this case, the Contractor provides health benefits to eligible employees in compliance with City policy.

**M/WBE PARTICIPATION:** The M/WBE goal established for this project is 24%. The original Contract amount totals \$1,120,000.00. The Consultant has been paid \$62,648.63 (5.59) % to date. Of this amount, \$44,919.00 (71.70) % has been paid to M/WBE sub-consultants to date. Assuming approval of the requested additional appropriation, the contract amount will increase to \$1,620,000.00. The Consultant proposes the following plan to meet the M/WBE goal.

<u>Name of Firms</u>	<u>Work Description</u>	<u>Amount</u>	<u>% of Total Contract</u>
Paid Prior M/WBE Commitment		\$ 44,919.00	2.77%
Unpaid Prior M/WBE Commitment		\$ 8,189.64	0.51%
1. Geotest Engineering, Inc.	Geotechnical Service	\$ 16,000.00	0.99%
2. B&E Reprographics, Inc.	Reproduction Service	\$ 2,879.36	0.18%

3. Crouch Environmental Services, Inc.	Environmental Engineering Service	\$ 12,000.00	0.74%
4. Midtown Engineers, LLC	Engineering Service	\$127,356.00	7.86%
5. GeoSurv, Inc. DBA TSC Surveying	Surveying Service	<u>\$180,000.00</u>	<u>11.11%</u>
<b>TOTAL</b>		<b>\$391,344.00</b>	<b>24.16%</b>

**ESTIMATED FISCAL OPERATING IMPACT:**

No significant Fiscal Operating impact is anticipated as a result of this project.

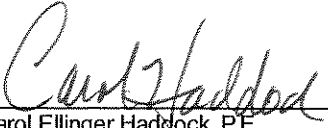
  
 Carol Ellinger Haddock, P.E.  
 Acting Director  
 Department of Public Works and Engineering

WBS No. M-430296-0011-3

**Prior Council Action:**

Ordinance 2016-0095, dated 01-27-2016

**Amount of Funding:**

**Total \$600,000.00** - Fund No. 4042—Street & Traffic Control and Storm Drainage DDSRF  
 (\$600,000.00 Supported by Drainage Fee)

Original (previous) appropriation of \$1,300,000.00 from Fund No. 4042 – Street & Traffic Control and Storm Drainage (DDSRF)

**Contact Information:**

Brian Alcott, P.E.  
 Acting Senior Assistant Director, Capital Projects  
 Phone: (832) 395-2396

**ATTACHMENTS:**

<b>Description</b>	<b>Type</b>
Maps	Backup Material
OBO (Vendor Info Sheets, Letters of Intent & MWBE Participation Schedule	Backup Material
Form B - Fair Campaign Ord.	Backup Material
Affidavit of Ownership (doc 0455)	Backup Material
Tax Report	Backup Material
Pay or Play (POP 1-3)	Backup Material
Form 1295	Backup Material
Prior Council Action - prior RCA & Ordinance	Backup Material
SAP (Form A & Funding docs)	Financial Information

0 15,000 30,000  
Feet

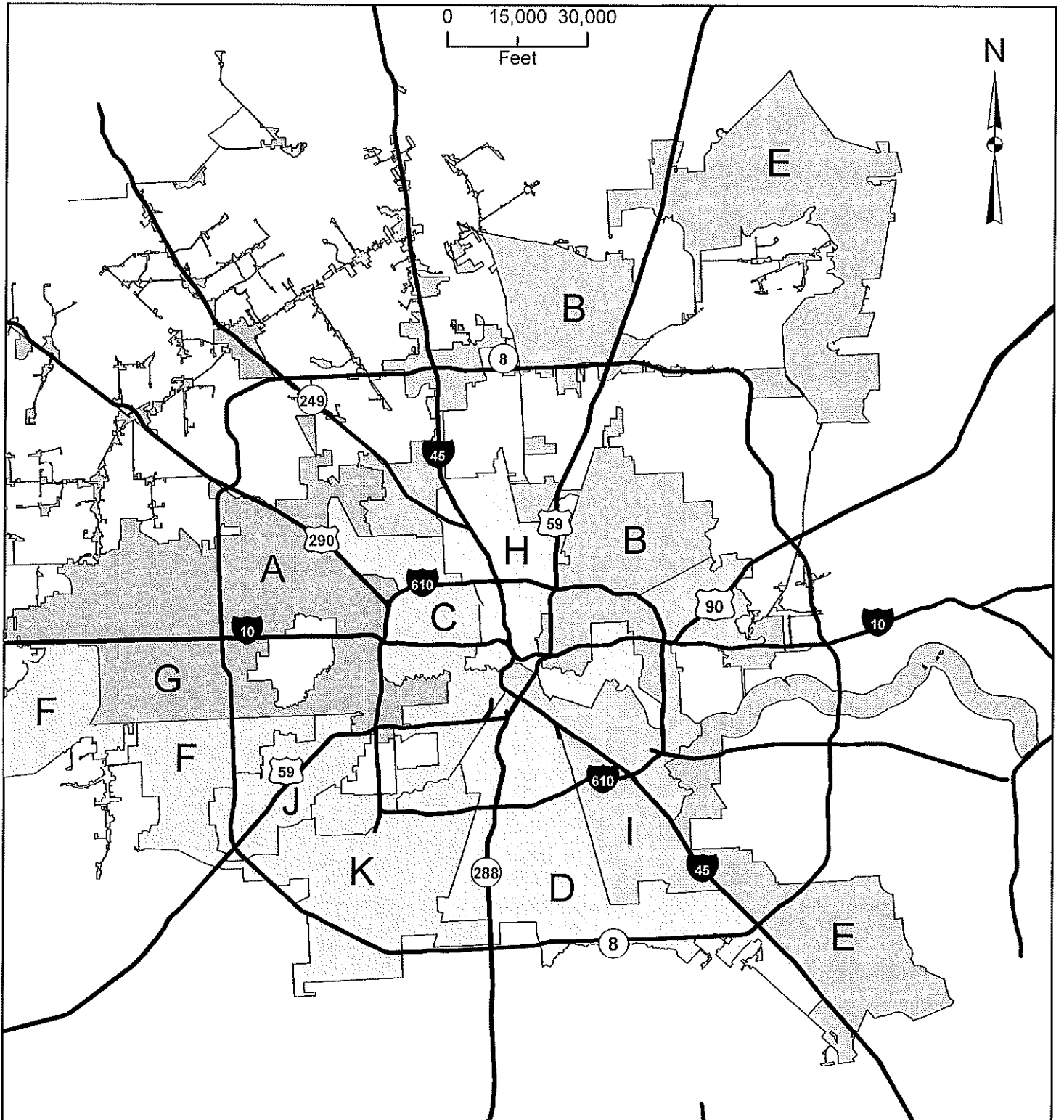

FY16 Mitigation Program for CIP Projects  
WBS NO. M-430296-0011-3  
KEY MAP NO. Various  
GIMS MAP NO. Various  
COUNCIL DISTRICT Various



**JONES | CARTER**

Texas Board of Professional Engineers Registration No. F-439



## CITY OF HOUSTON - CITY COUNCIL

Meeting Date: 11/8/2017

District B

Item Creation Date:

### 20JDF34/EASEMENT ACQUISITIONS FOR 108-INCH WATER LINE FROM IMPERIAL VALLEY DRIVE TO GREEN PLAZA DRIVE

Agenda Item#: 20.

#### **Summary:**

ORDINANCE finding and determining public convenience and necessity for the acquisition of easements through dedication, purchase or condemnation, in connection with the public improvement project known as the 108-inch water line from Imperial Valley Drive to Green Plaza Drive Project; authorizing the payment of costs for parcel purchases/condemnations, relocation assistance expenses, appraisal fees, title policies/ services, recording fees, court costs, expert witness fees and other acquisition costs in connection with the project, located in the William Sevey Survey, A-699 and the Simon Contreras Survey, A-220, Houston, Harris County, Texas  
**DISTRICT B - DAVIS**

#### **Background:**

**SUBJECT:** Recommendation that an ordinance for the EASEMENT ACQUISITIONS FOR 108-INCH WATER LINE FROM IMPERIAL VALLEY DRIVE TO GREEN PLAZA DRIVE be passed approving and authorizing the acquisition of parcels by dedication, purchase, or condemnation.

WBS S-000900-0168-2

**RECOMMENDATION: (Summary)** An ordinance for the EASEMENT ACQUISITIONS FOR 108-INCH WATER LINE FROM IMPERIAL VALLEY DRIVE TO GREEN PLAZA DRIVE be passed approving and authorizing the acquisition of parcels by dedication, purchase, or condemnation.

#### **SPECIFIC EXPLANATION:**

The project provides for the design and construction of transmission and distribution lines to convey treated water from surface water facilities. This project is part of the City's regionalization program and is in compliance with the Harris-Galveston Subsidence District requirement to implement the City's long range water supply plan. The subject water line easement parcels are needed for the Northeast Transmission Line segment of the program.

This action authorizes payment for costs of land purchases/condemnations, relocation assistance expenses, appraisal fees, title policies/services, recording fees and other acquisition costs in connection with negotiations to settle purchases; finds a public necessity for the project; and approves and authorizes the condemnation of the land and improvements thereon. If negotiations

to acquire the property cannot be concluded as a dedication or purchase or for any reason for which acquisition by condemnation is warranted, this action authorizes the City Attorney to file or cause Eminent Domain proceedings to be filed and acquire land, rights-of-way and/or easements for said purposes and authorizes payment for the Award of Special Commissioners and court costs associated with condemnation proceedings. Parcels with a consideration that exceeds the spending authority threshold set by State law will be submitted to City Council as they are finalized. This will expedite the process of acquiring land, rights-of-way and/or easements in support of the EASEMENT ACQUISITIONS FOR 108-INCH WATER LINE FROM IMPERIAL VALLEY DRIVE TO GREEN PLAZA DRIVE.

**Prior Council Action:**

Ordinance No. 2016-758, passed October 5, 2016

**Amount of Funding:**

No additional funding required.

**Contact Information:**

Darrin Ward  
Acting Senior Assistant Director- Real Estate Services  
Phone: (832) 395-3154

---

Carol Ellinger Haddock, P.E.  
Acting Director  
Department of Public Works and Engineering

WBS S-000900-0168-2

**ATTACHMENTS:**

**Description**

Signed Coversheet

**Type**

Signed Cover sheet



## CITY OF HOUSTON - CITY COUNCIL

Meeting Date:  
District B  
Item Creation Date:

### 20JDF34/EASEMENT ACQUISITIONS FOR 108-INCH WATER LINE FROM IMPERIAL VALLEY DRIVE TO GREEN PLAZA DRIVE

Agenda Item#:

#### **Background:**

**SUBJECT:** Recommendation that an ordinance for the EASEMENT ACQUISITIONS FOR 108-INCH WATER LINE FROM IMPERIAL VALLEY DRIVE TO GREEN PLAZA DRIVE be passed approving and authorizing the acquisition of parcels by dedication, purchase, or condemnation.  
WBS S-000900-0168-2

**RECOMMENDATION: (Summary)** An ordinance for the EASEMENT ACQUISITIONS FOR 108-INCH WATER LINE FROM IMPERIAL VALLEY DRIVE TO GREEN PLAZA DRIVE be passed approving and authorizing the acquisition of parcels by dedication, purchase, or condemnation.

#### **SPECIFIC EXPLANATION:**

The project provides for the design and construction of transmission and distribution lines to convey treated water from surface water facilities. This project is part of the City's regionalization program and is in compliance with the Harris-Galveston Subsidence District requirement to implement the City's long range water supply plan. The subject water line easement parcels are needed for the Northeast Transmission Line segment of the program.

This action authorizes payment for costs of land purchases/condemnations, relocation assistance expenses, appraisal fees, title policies/services, recording fees and other acquisition costs in connection with negotiations to settle purchases; finds a public necessity for the project; and approves and authorizes the condemnation of the land and improvements thereon. If negotiations to acquire the property cannot be concluded as a dedication or purchase or for any reason for which acquisition by condemnation is warranted, this action authorizes the City Attorney to file or cause Eminent Domain proceedings to be filed and acquire land, rights-of-way and/or easements for said purposes and authorizes payment for the Award of Special Commissioners and court costs associated with condemnation proceedings. Parcels with a consideration that exceeds the spending authority threshold set by State law will be submitted to City Council as they are finalized. This will expedite the process of acquiring land, rights-of-way and/or easements in support of the EASEMENT ACQUISITIONS FOR 108-INCH WATER LINE FROM IMPERIAL VALLEY DRIVE TO GREEN PLAZA DRIVE.

#### **Prior Council Action:**

Ordinance No. 2016-758, passed October 5, 2016

#### **Amount of Funding:**

No additional funding required.

#### **Contact Information:**

Darrin Ward  
Acting Senior Assistant Director- Real Estate Services  
Phone: (832) 395-3154

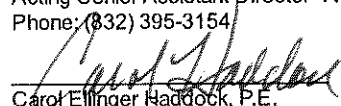
  
Carol Ellinger Haddock, P.E.  
Acting Director  
Department of Public Works and Engineering

WBS S-000900-0168-2

**ATTACHMENTS:**

**Description**

ORDINANCE 2016-758

SURVEYS and METES AND BOUNDS

LOCATION MAP

**Type**

Backup Material

Backup Material

Backup Material



## CITY OF HOUSTON - CITY COUNCIL

Meeting Date: 11/8/2017

District C

Item Creation Date: 10/4/2017

20MRH15\Shepherd and Durham Paving and Drainage  
(from Washington Avenue to Dickson Street) Project

Agenda Item#: 21.

### **Summary:**

ORDINANCE finding and determining public convenience and necessity for the acquisition of real property interests through dedication, purchase or condemnation, in connection with the public improvement project known as Shepherd and Durham Paving and Drainage (from Washington Avenue to Dickson Street) Project; authorizing the acquisition of fee simple title interest in or easement purchase and the use of eminent domain and authorizing the payment of costs for parcel purchases/condemnations, relocation assistance expenses, appraisal fees, title policies/services, recording fees, court costs, expert witness fees and other acquisition costs in connection with the project, located in the John Austin Survey, A-1, Houston, Harris County, Texas

### **DISTRICT C - COHEN**

### **Background:**

**SUBJECT:** Recommendation that an ordinance for the SHEPHERD AND DURHAM PAVING AND DRAINAGE (FROM WASHINGTON AVENUE TO DICKSON STREET) PROJECT be passed approving and authorizing the acquisition of parcels by dedication, purchase, or condemnation.

WBS N-100003-0001-2

### **RECOMMENDATION: (Summary)**

An ordinance for the SHEPHERD AND DURHAM PAVING AND DRAINAGE (FROM WASHINGTON AVENUE TO DICKSON STREET) PROJECT be passed approving and authorizing the acquisition of parcels by dedication, purchase, or condemnation.

### **SPECIFIC EXPLANATION:**

The Department of Public Works and Engineering is requesting that an ordinance for the SHEPHERD AND DURHAM PAVING AND DRAINAGE (FROM WASHINGTON AVENUE TO DICKSON STREET) PROJECT be passed approving and authorizing the acquisition of parcels by dedication, purchase, or condemnation.

This project is needed to replace segments of Shepherd Drive and Durham Drive that have deteriorated beyond economical repair and normal maintenance. This project provides for the design and construction of an eight lane (four lanes of Shepherd and Durham divided concrete roadway with curbs, sidewalks, driveways, street lighting, traffic control and necessary underground utilities. The project will improve traffic circulation, drainage, and safety in the service area.

This action authorizes payment for costs of land purchases/condemnations, relocation assistance expenses, appraisal fees, title policies/services, recording fees and other acquisition costs in connection with negotiations to settle purchases; finds a public necessity for the project; and approves and authorizes the condemnation of the land and improvements thereon. If negotiations to acquire the property cannot be concluded as a dedication or purchase or for any reason for which acquisition by condemnation is warranted, this action authorizes the City Attorney to file or cause Eminent Domain proceedings to be filed and acquire land, rights-of-way and/or easements for said purposes and authorizes payment for the Award of Special Commissioners and court costs associated with condemnation proceedings. Parcels with a consideration that exceeds the spending authority threshold set by State law will be submitted to City Council as they are finalized. This will expedite the process of acquiring land, rights-of-way and/or easements in support of the SHEPHERD AND DURHAM PAVING AND DRAINAGE (FROM WASHINGTON AVENUE TO DICKSON STREET) PROJECT.

**Prior Council Action:**

Ordinance 2017-373, passed May 24, 2017.

**Amount of Funding:**

No additional funding required.

**Contact Information:**

Darrin Ward  
Acting Senior Assistant Director-Real Estate Services  
Phone: (832) 395-3154

---

Carol Ellinger Haddock, P.E.  
Acting Director  
Department of Public Works and Engineering

WBS N-100003-0001-2

**ATTACHMENTS:**

**Description**

Signed Coversheet

**Type**

Signed Cover sheet



**CITY OF HOUSTON - CITY COUNCIL**

Meeting Date:

District C

Item Creation Date: 10/4/2017

20MRH15\Shepherd and Durham Paving and Drainage (from Washington Avenue to Dickson Street) Project

Agenda Item#:

**Background:**

**SUBJECT:** Recommendation that an ordinance for the SHEPHERD AND DURHAM PAVING AND DRAINAGE (FROM WASHINGTON AVENUE TO DICKSON STREET) PROJECT be passed approving and authorizing the acquisition of parcels by dedication, purchase, or condemnation.

WBS N-100003-0001-2

**RECOMMENDATION: (Summary)**

An ordinance for the SHEPHERD AND DURHAM PAVING AND DRAINAGE (FROM WASHINGTON AVENUE TO DICKSON STREET) PROJECT be passed approving and authorizing the acquisition of parcels by dedication, purchase, or condemnation.

**SPECIFIC EXPLANATION:**

The Department of Public Works and Engineering is requesting that an ordinance for the SHEPHERD AND DURHAM PAVING AND DRAINAGE (FROM WASHINGTON AVENUE TO DICKSON STREET) PROJECT be passed approving and authorizing the acquisition of parcels by dedication, purchase, or condemnation.

This project is needed to replace segments of Shepherd Drive and Durham Drive that have deteriorated beyond economical repair and normal maintenance. This project provides for the design and construction of an eight lane (four lanes of Shepherd and Durham divided concrete roadway with curbs, sidewalks, driveways, street lighting, traffic control and necessary underground utilities. The project will improve traffic circulation, drainage, and safety in the service area.

This action authorizes payment for costs of land purchases/condemnations, relocation assistance expenses, appraisal fees, title policies/services, recording fees and other acquisition costs in connection with negotiations to settle purchases; finds a public necessity for the project; and approves and authorizes the condemnation of the land and improvements thereon. If negotiations to acquire the property cannot be concluded as a dedication or purchase or for any reason for which acquisition by condemnation is warranted, this action authorizes the City Attorney to file or cause Eminent Domain proceedings to be filed and acquire land, rights-of-way and/or easements for said purposes and authorizes payment for the Award of Special Commissioners and court costs associated with condemnation proceedings. Parcels with a consideration that exceeds the spending authority threshold set by State law will be submitted to City Council as they are finalized. This will expedite the process of acquiring land, rights-of-way and/or easements in support of the SHEPHERD AND DURHAM PAVING AND DRAINAGE (FROM WASHINGTON AVENUE TO DICKSON STREET) PROJECT.

**Prior Council Action:**

Ordinance 2017-373, passed May 24, 2017.

**Amount of Funding:**

No additional funding required.

**Contact Information:**

Darrin Ward

Acting Senior Assistant Director-Real Estate Services

Phone: (832) 395-3154

Carol Ellinger Haddock, P.E.

Acting Director

Department of Public Works and Engineering

WBS N-100003-0001-2

**ATTACHMENTS:**

**Description**

Location Map  
Survey and Metes and Bounds  
Ordinance 2017-373

**Type**

Backup Material  
Backup Material  
Backup Material



## CITY OF HOUSTON - CITY COUNCIL

Meeting Date: 11/8/2017

ALL

Item Creation Date: 9/25/2017

20WWO695 Contract Award/Portland Utilities Construction  
Company, LLC

Agenda Item#: 22.

### **Summary:**

ORDINANCE appropriating \$2,760,878.00 out of Water & Sewer System Consolidated Construction Fund; awarding contract to **PORTLAND UTILITIES CONSTRUCTION COMPANY, LLC** for Wastewater Collection System Rehabilitation and Renewal; setting a deadline for the bidder's execution of the contract and delivery of all bonds, insurance, and other required contract documents to the City; holding the bidder in default if it fails to meet the deadlines; providing funding for the engineering and testing, and contingencies relating to the construction of facilities financed by the Water & Sewer System Consolidated Construction Fund (WW4235-102)

### **Background:**

**SUBJECT:** Contract Award for Wastewater Collection System Rehabilitation and Renewal.

**RECOMMENDATION:** (Summary) Accept low bid, award construction contract, and appropriate funds.

**SPECIFIC EXPLANATION:** This project is part of the Neighborhood Sewer Rehabilitation Program and is required to renew/replace various deteriorated neighborhood collection systems throughout the City. The project involves wastewater collection system rehabilitation and renewal. The purpose is to reduce sanitary sewer overflows, which is accomplished by renewal/rehabilitation of deteriorated collection systems.

**DESCRIPTION/SCOPE:** This project consists of wastewater collection system rehabilitation and renewal. The contract duration for this project is 540 calendar days.

**LOCATION:** The project area is generally bounded by the City Limits.

**BIDS:** Seven (7) bids were received on July 20, 2017 for this project as follows:

	<b><u>Bidder</u></b>	<b><u>Bid Amount</u></b>
1.	Portland Utilities Construction Company, LLC	\$2,586,550.37
2.	Vaught Services, LLC	\$2,632,931.24
3.	Lopez Utilities Contractor, LLC	\$2,752,037.33
4.	Nerie Construction, LLC	\$3,071,137.75

5.	T Construction, LLC	\$3,200,633.15
6.	PM Construction & Rehab, LLC	\$3,529,380.80
7.	Horseshoe Construction, Inc.	\$4,277,040.50

**AWARD:** It is recommended that this construction contract be awarded to Portland Utilities Construction Company, LLC, with a low bid of \$2,586,550.37

**PROJECT COST:** The total cost of this project is \$2,760,878.00 to be appropriated as follows:

Bid Amount	\$2,586,550.37
Contingencies	\$129,327.63
Engineering Testing Services	\$45,000.00

Engineering Testing Services will be provided by Alpha Testing, Inc. under a previously approved contract.

**HIRE HOUSTON FIRST:** Hire Houston First does not apply to this expenditure, because it involves the use of federal funds and is subject to specific procurement rules of the federal government.

**PAY OR PLAY PROGRAM:** The proposed contract requires compliance with the City's Pay or Play ordinance regarding health benefits for employees of City contractors. In this case, the contractor provides benefits for employees but will pay into the Contractor Responsibility Fund for others, in compliance with City policy.

**M/WSBE PARTICIPATION:** The contractor has submitted the following proposed program to satisfy the 12.94% MBE goal, and 8.72% WBE goal for this project.

<u>MBE – Name of Firm</u>	<u>Work Description</u>	<u>Amount</u>	<u>% of Contract</u>
CZ Construction, LLC	Sewer Services & Pipe Bursting	\$125,000.00	4.83%
Texas Pride Utilities, LLC	Sewer Rehab & Restoration	\$125,000.00	4.83%
Big Country 94 Asphalt Construction, L.L.C.	Concrete & Asphalt Paving	\$84,712.00	3.28%
	<b>MBE TOTAL</b>	<b>\$334,712.00</b>	<b>12.94%</b>
<u>WBE – Name of Firm</u>	<u>Work Description</u>	<u>Amount</u>	<u>% of Contract</u>
J.A. Gamez Trucking Services	Dump Truck Services	\$75,000.00	2.90%
Deanie Hayes, Inc.	Supplies	\$75,000.00	2.90%
Advantage Manhole & Concrete Services, Inc.	Manhole Rehabilitation	\$75,547.19	2.92%
	<b>WBE TOTAL</b>	<b>\$225,547.19</b>	<b>8.72%</b>

**ESTIMATED FISCAL OPERATING IMPACT:**

No significant Fiscal Operating impact is anticipated as a result of this project.

All known rights-of-way and easements required for this project have been acquired.

---

Carol Ellinger Haddock, P.E.  
Acting Director  
Department of Public Works and Engineering

WBS# R-000266-0270-4  
File No. WW4235-102

**Prior Council Action:**

**Amount of Funding:**

\$2,760,878.00  
Water and Sewer System Consolidated Construction Fund  
Fund No. 8500.

This project is eligible for low interest funding through a State Revolving Fund (SRF) Equivalency loan

**Contact Information:**

Shannon Dunne  
Acting Senior Assistant Director  
**Phone:** (832) 395-5036

**ATTACHMENTS:**

**Description**

Signed Coversheet

**Type**

Signed Cover sheet



**CITY OF HOUSTON - CITY COUNCIL**

Meeting Date:

ALL

Item Creation Date: 9/25/2017

20WVO695 Contract Award/Portland Utilities Construction Company, LLC

Agenda Item#:

**Summary:**

AN ORDINANCE APPROPRIATING THE SUM OF **\$2,760,878.00** OUT OF THE WATER AND SEWER SYSTEM CONSOLIDATED CONSTRUCTION FUND; AWARDING A CONTRACT TO PORTLAND UTILITIES CONSTRUCTION COMPANY, LLC FOR WASTEWATER COLLECTION SYSTEM REHABILITATION AND RENEWAL; SETTING A DEADLINE FOR THE BIDDER'S EXECUTION OF THE CONTRACT AND DELIVERY OF ALL BONDS, INSURANCE, AND OTHER REQUIRED CONTRACT DOCUMENTS TO THE CITY; HOLDING THE BIDDER IN DEFAULT IF IT FAILS TO MEET THE DEADLINES; PROVIDING FUNDING FOR ENGINEERING AND TESTING, AND CONTINGENCIES RELATING TO CONSTRUCTION OF FACILITIES FINANCED BY THE WATER AND SEWER SYSTEM CONSOLIDATED CONSTRUCTION FUND; AND DECLARING AN EMERGENCY.

**Background:**

**SUBJECT:** Contract Award for Wastewater Collection System Rehabilitation and Renewal.

**RECOMMENDATION:** (Summary) Accept low bid, award construction contract, and appropriate funds.

**SPECIFIC EXPLANATION:** This project is part of the Neighborhood Sewer Rehabilitation Program and is required to renew/replace various deteriorated neighborhood collection systems throughout the City. The project involves wastewater collection system rehabilitation and renewal. The purpose is to reduce sanitary sewer overflows, which is accomplished by renewal/rehabilitation of deteriorated collection systems.

**DESCRIPTION/SCOPE:** This project consists of wastewater collection system rehabilitation and renewal. The contract duration for this project is 540 calendar days.

**LOCATION:** The project area is generally bounded by the City Limits.

**BIDS:** Seven (7) bids were received on July 20, 2017 for this project as follows:

	Bidder	Bid Amount
1.	Portland Utilities Construction Company, LLC	\$2,586,550.37
2.	Vaught Services, LLC	\$2,632,931.24
3.	Lopez Utilities Contractor, LLC	\$2,752,037.33
4.	Nerie Construction, LLC	\$3,071,137.75
5.	T Construction, LLC	\$3,200,633.15
6.	PM Construction & Rehab, LLC	\$3,529,380.80
7.	Horseshoe Construction, Inc.	\$4,277,040.50

**AWARD:** It is recommended that this construction contract be awarded to Portland Utilities Construction Company, LLC, with a low bid of \$2,586,550.37

**PROJECT COST:** The total cost of this project is \$2,760,878.00 to be appropriated as follows:

Bid Amount	\$2,586,550.37
Contingencies	\$129,327.63
Engineering Testing Services	\$45,000.00

Engineering Testing Services will be provided by Alpha Testing, Inc. under a previously approved contract.

**HIRE HOUSTON FIRST:** Hire Houston First does not apply to this expenditure, because it involves the use of federal funds and is subject to specific procurement rules of the federal government.

**PAY OR PLAY PROGRAM:** The proposed contract requires compliance with the City's Pay or Play ordinance regarding health benefits for employees of City contractors. In this case, the contractor provides benefits for employees but will pay into the Contractor Responsibility Fund for others, in compliance with City policy.

**MWSBE PARTICIPATION:** The contractor has submitted the following proposed program to satisfy the 12.94% MBE goal, and 8.72% WBE goal for this project.

<u>MBE – Name of Firm</u>	<u>Work Description</u>	<u>Amount</u>	<u>% of Contract</u>
CZ Construction, LLC	Sewer Services & Pipe Bursting	\$125,000.00	4.83%
Texas Pride Utilities, LLC	Sewer Rehab & Restoration	\$125,000.00	4.83%
Big Country 94 Asphalt Construction, L.L.C.	Concrete & Asphalt Paving	\$84,712.00	3.28%
	<b>MBE TOTAL</b>	<b>\$334,712.00</b>	<b>12.94%</b>
<u>WBE – Name of Firm</u>	<u>Work Description</u>	<u>Amount</u>	<u>% of Contract</u>
J.A. Gamez Trucking Services	Dump Truck Services	\$75,000.00	2.90%
Deanie Hayes, Inc.	Supplies	\$75,000.00	2.90%
Advantage Manhole & Concrete Services, Inc.	Manhole Rehabilitation	\$75,547.19	2.92%
	<b>WBE TOTAL</b>	<b>\$225,547.19</b>	<b>8.72%</b>

**ESTIMATED FISCAL OPERATING IMPACT:**

No significant Fiscal Operating impact is anticipated as a result of this project.

All known rights-of-way and easements required for this project have been acquired.

  
 Carol Ellinger Haddock, P.E.  
 Acting Director  
 Department of Public Works and Engineering

WBS# R-000266-0270-4  
 File No. WW4235-102

**Prior Council Action:**  
 N/A

**Amount of Funding:**  
 \$2,760,878.00 from Water and Sewer System Consolidated Construction Fund No. 8500. This project is eligible for low interest funding through a State Revolving Fund (SRF) Equivalency loan

**Contact Information:**  
 Shannon Dunne  
 Acting Senior Assistant Director  
 Phone: (832) 395-5036

**ATTACHMENTS:**

<b>Description</b>	<b>Type</b>
Form A	Backup Material
Draft Ordinance	Backup Material
Tax Report	Backup Material
00455 - Ownership Information Form	Backup Material
Bid Tabulation	Backup Material
00600 - List of Proposed Subcontractors and Suppliers	Backup Material
MWRF Letters of Intent	Backup Material

MWBE Letters of Intent

MWBE Certifications	Backup Material
00452 - Contractor Submission List Campaign Finance Ordinance Form B	Backup Material
00251 - Pre-bid Meeting Agenda	Backup Material
00410B - Bid Form	Backup Material
Testing Lab Information	Backup Material
00460 (POP-1) - Pay or Play Acknowledgement Form	Backup Material
00631 (POP-3) Pay or Play Program List of Subcontractors	Backup Material
00630 (POP-2) - Certification of Compliance with Pay or Play Program	Backup Material
Map	Backup Material
Form 1295 - Certificate of Interested Parties	Backup Material
Bid Extension	Backup Material
SAP Documents	Backup Material



## CITY OF HOUSTON - CITY COUNCIL

Meeting Date: 11/8/2017

District D, District E

Item Creation Date: 7/28/2017

20NP09 Contract Award / Precise Services, Inc.

Agenda Item#: 23.

### **Summary:**

ORDINANCE appropriating \$3,222,181.00 out of Metro Projects Construction DDSRF, awarding contract to **PRECISE SERVICES, INC** for Roadway Pavement Replacement Project: Martinville Drive and Sunbeam Street; setting a deadline for the bidder's execution of the contract and delivery of all bonds, insurance, and other required contract documents to the City; holding the bidder in default if it fails to meet the deadlines; providing funding for testing services, CIP Cost Recovery, and contingencies relating to construction of facilities financed by the Metro Projects Construction DDSRF - **DISTRICTS D - BOYKINS and E - MARTIN**

### **Background:**

**SUBJECT:** Contract Award for Roadway Pavement Replacement Project: Martinville Drive and Sunbeam Street WBS No. N-321039-001A-4

**RECOMMENDATION:** (Summary) Accept low bid, award Construction Contract and appropriate funds.

**PROJECT NOTICE/JUSTIFICATION:** This project is part of the Roadway Pavement Replacement program and is required to improve and maintain a safe road surface and accessibility, and to prolong the life of the roadway.

**DESCRIPTION/SCOPE:** The project consists of existing pavement replacement with new hot mix asphalt pavement along with ditch regrading. The contract duration for this project is 335 calendar days.

**LOCATION:** The project is located at Martinville Drive (Richey St to Kolb Rd) and Sunbeam Street (Cullen Blvd to MLK Blvd).

**BIDS:** This project was advertised for bidding on March 31 and April 7, 2016. Bids were received on April 20, 2017. The two bids are as follows:

	<u>Bidder</u>	<u>Bid Amount</u>
1.	Precise Services, Inc.	\$2,585,150.25
2.	Durwood Greene Construction Co.	\$2,698,785.50

**AWARD:** It is recommended that this construction contract be awarded to Precise Services, Inc. with a bid of \$2,585,150.25 and Addendum Number 1 be made a part of this Contract.

**PROJECT COST:** The total cost of this project is \$3,222,181.00 to be appropriated as follows:

· Bid Amount	\$2,585,150.25
· Contingencies	\$129,257.51
· Testing Services	\$120,000.00
· CIP Cost Recovery	\$387,773.24

Testing Services will be provided by Alliance Laboratories, Inc. under a previously approved contract.

**HIRE HOUSTON FIRST:** The proposed contract requires compliance with the City's 'Hire Houston First' (HHF) ordinance that promotes economic opportunity for Houston business and supports job creation. In this case, Precise Services, Inc. is a designated HHF company, but they were the successful awardee without application of the HHF preference.

**PAY OR PLAY PROGRAM:** The proposed contract requires compliance with the City's 'Pay or Play' ordinance regarding health benefits for employees of City contractors. In this case, the Contractor has elected to pay into the Contractor Responsibility Fund in compliance with City policy.

**M/WSBE PARTICIPATION:** The contractor has submitted the following proposed program to satisfy the 12 % MBE goal and 7 % WBE goal for this project.

<u>MBE - Name of Firms</u>	<u>Work Description</u>	<u>Amount</u>	<u>% of Contract</u>
1. GMJ Paving Company LLC	Asphalt Paving	\$557,358.39	21.56%
	<b>Total</b>	<b>\$557,358.39</b>	<b>21.56%</b>

<u>WBE - Name of Firms</u>	<u>Work Description</u>	<u>Amount</u>	<u>% of Contract</u>
1. Willow City Sign & Rail, Inc.	Guardrail	\$33,089.92	1.28%
2. Republic Traffic Safety, Inc.	Traffic control sign, Flagging	\$77,037.47	2.98%
3. Construction & Maintenance Service	Flagging	\$41,362.40	1.60%
4. Pipe Wholesalers of Texas, Inc.	Construction material supply	\$112,195.52	4.34%
	<b>Total</b>	<b>\$263,685.31</b>	<b>10.20%</b>

**ESTIMATED FISCAL OPERATING IMPACT:** No significant Fiscal Operating impact is anticipated as a result of this project.

---

Carol Ellinger Haddock, P.E.  
Acting Director  
Department of Public Works and Engineering

WBS No. N-321039-001A-4

**Amount of Funding:**

\$3,222,181.00 from Fund No.4040 – METRO Projects Construction DDSRF  
(\$3,222,181.00 supported by METRO fund)

**Contact Information:**

Thomas Artz, P.E.,  
Acting Assistant Director  
Rapid Delivery, Capital Projects  
**Phone:** (832) 395-2222

**ATTACHMENTS:**

**Description**

Signed Coversheet  
Maps

**Type**

Signed Cover sheet  
Backup Material



**CITY OF HOUSTON - CITY COUNCIL**

Meeting Date:  
District D, District E  
Item Creation Date: 7/28/2017

20NP09 Contract Award / Precise Services, Inc.

Agenda Item#:

**Background:**

**SUBJECT:** Contract Award for Roadway Pavement Replacement Project: Martinville Drive and Sunbeam Street WBS No. N-321039-001A-4

**RECOMMENDATION:** (Summary) Accept low bid, award Construction Contract and appropriate funds.

**PROJECT NOTICE/JUSTIFICATION:** This project is part of the Roadway Pavement Replacement program and is required to improve and maintain a safe road surface and accessibility, and to prolong the life of the roadway.

**DESCRIPTION/SCOPE:** The project consists of existing pavement replacement with new hot mix asphalt pavement along with ditch regrading. The contract duration for this project is 335 calendar days.

**LOCATION:** The project is located at Martinville Drive (Richey St to Kolb Rd) and Sunbeam Street (Cullen Blvd to MLK Blvd).

**BIDS:** This project was advertised for bidding on March 31 and April 7, 2016. Bids were received on April 20, 2017. The two bids are as follows:

	<u>Bidder</u>	<u>Bid Amount</u>
1.	Precise Services, Inc.	\$2,585,150.25
2.	Durwood Greene Construction Co.	\$2,698,785.50

**AWARD:** It is recommended that this construction contract be awarded to Precise Services, Inc. with a bid of \$2,585,150.25 and Addendum Number 1 be made a part of this Contract.

**PROJECT COST:** The total cost of this project is \$3,222,181.00 to be appropriated as follows:

· Bid Amount	\$2,585,150.25
· Contingencies	\$129,257.51
· Testing Services	\$120,000.00
· CIP Cost Recovery	\$387,773.24

Testing Services will be provided by Alliance Laboratories, Inc. under a previously approved contract.

**HIRE HOUSTON FIRST:** The proposed contract requires compliance with the City's 'Hire Houston First' (HHF) ordinance that promotes economic opportunity for Houston business and supports job creation. In this case, Precise Services, Inc. is a designated HHF company, but they were the successful awardee without application of the HHF preference.

**PAY OR PLAY PROGRAM:** The proposed contract requires compliance with the City's 'Pay or Play' ordinance regarding health benefits for employees of City contractors. In this case, the Contractor has elected to pay into the Contractor Responsibility Fund in compliance with City policy.

**M/WSBE PARTICIPATION:** The contractor has submitted the following proposed program to satisfy the 12 % MBE goal and 7 % WBE goal for this project.

<u>MBE - Name of Firms</u>	<u>Work Description</u>	<u>Amount</u>	<u>% of Contract</u>
1. GMJ Paving Company LLC	Asphalt Paving	\$557,358.39	21.56%
	<b>Total</b>	<b>\$557,358.39</b>	<b>21.56%</b>

<u>WBE - Name of Firms</u>	<u>Work Description</u>	<u>Amount</u>	<u>% of Contract</u>
1. Willow City Sign & Rail, Inc.	Guardrail	\$33,089.92	1.28%
2. Republic Traffic Safety, Inc.	Traffic control sign, Flagging	\$77,037.47	2.98%
3. Construction & Maintenance Service	Flagging	\$41,362.40	1.60%
4. Pipe Wholesalers of Texas, Inc.	Construction material supply	<u>\$112,195.52</u>	<u>4.34%</u>
	<b>Total</b>	<b>\$263,685.31</b>	<b>10.20%</b>

**ESTIMATED FISCAL OPERATING IMPACT:** No significant Fiscal Operating impact is anticipated as a result of this project.



Carol Ellinger Haddock, P.E.  
Acting Director  
Department of Public Works and Engineering

WBS No. N-321039-001A-4

**Amount of Funding:**

\$3,222,181.00 from Fund No.4040 – METRO Projects Construction DDSRF  
(\$3,222,181.00 supported by METRO fund)

**Contact Information:**

Thomas Artz, P.E.,  
Acting Assistant Director  
Rapid Delivery, Capital Projects  
Phone: (832) 395-2222

**ATTACHMENTS:**

<b>Description</b>	<b>Type</b>
Maps	Backup Material
Draft Ordinance	Backup Material
Vendor Info Sheets	Backup Material
Letters of Intent	Backup Material
Form A 0452 Document	Backup Material
Form B	Backup Material
Affidavit of Ownership	Backup Material
Tax Report	Backup Material
Pay or Play (POP 1-3)	Backup Material
Bid Extension Letter	Backup Material
Form 1295	Backup Material

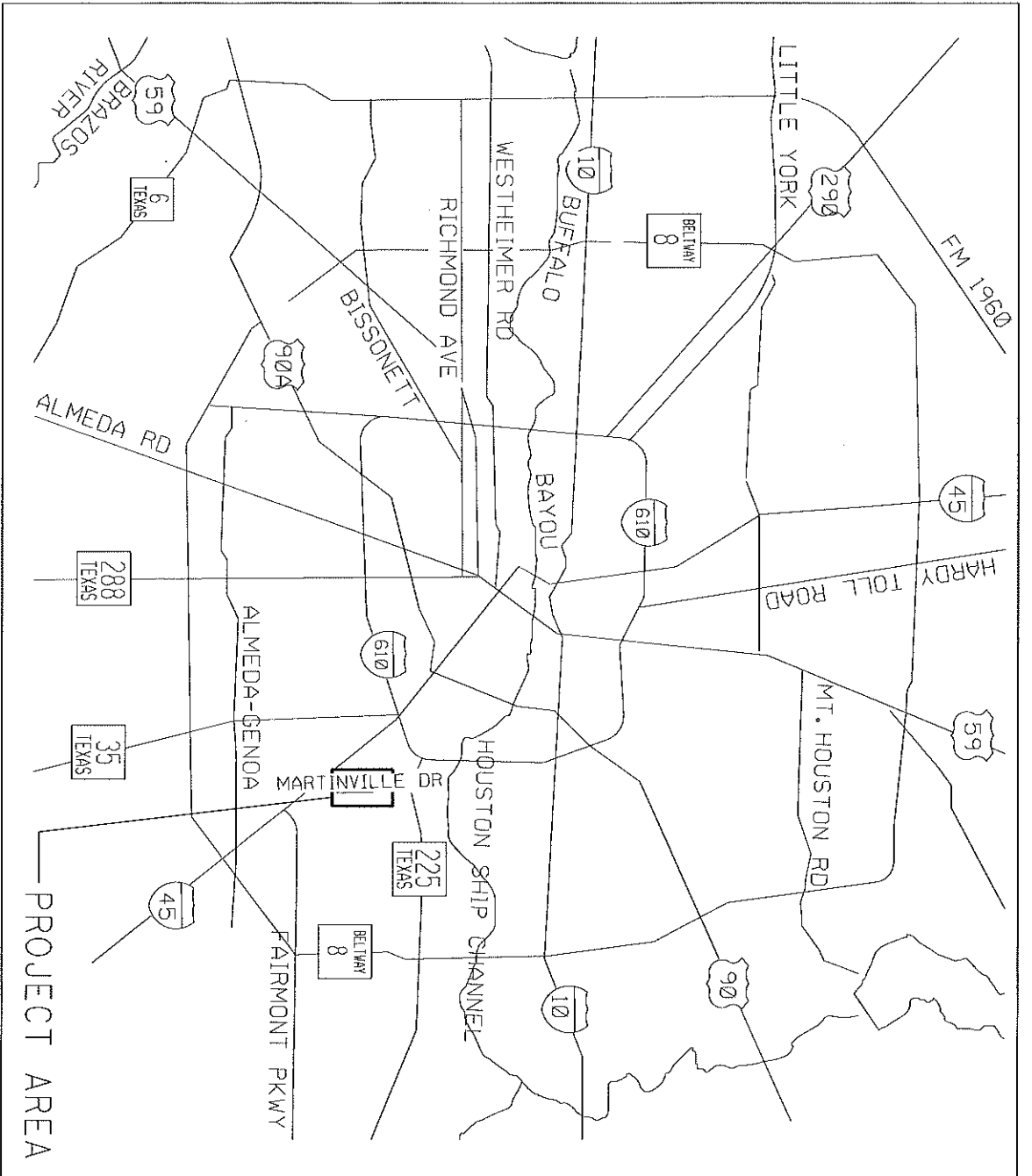

ROADWAY PAVEMENT REPLACEMENT PROJECT

MARTINVILLE DR

WBS NO. N-321039-001A-4

COUNCIL DISTRICT "E"

KEYMAP GRID 536T, 536X

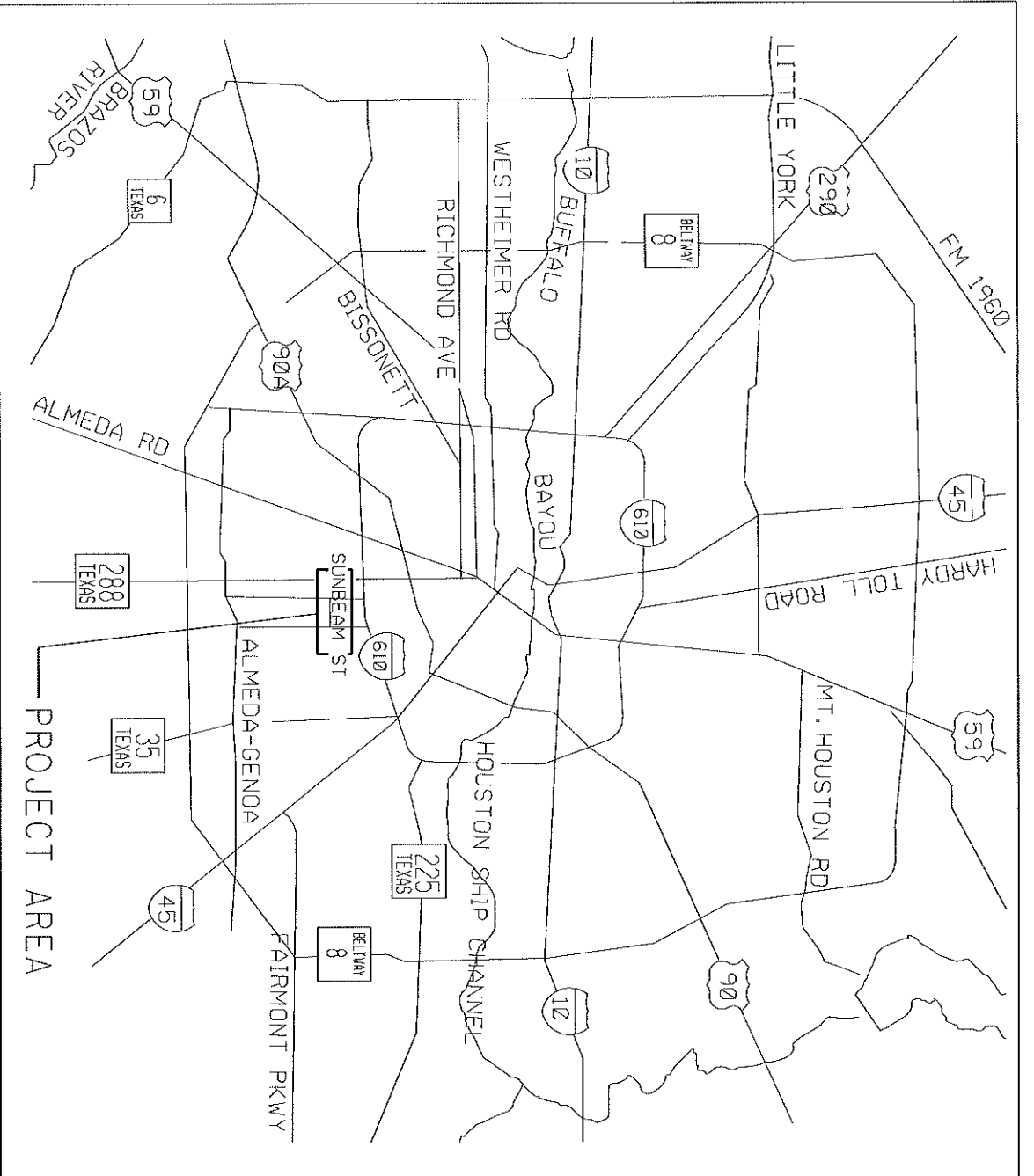

ROADWAY PAVEMENT REPLACEMENT PROJECT  
 SUNBEAM ST

WBS NO. N-321039-001A-4  
 COUNCIL DISTRICT "D"  
 KEYMAP GRID 573D, 574A



## CITY OF HOUSTON - CITY COUNCIL

Meeting Date: 11/8/2017

District G

Item Creation Date: 8/15/2017

20RH04 Contract Award / SER Construction Partners

Agenda Item#: 24.

### **Summary:**

ORDINANCE appropriating \$6,350,000.00 out of Street & Traffic Control and Storm Drainage DDSRF awarding contract to **SER CONSTRUCTION PARTNERS, LLC.** for Yorkshire Area Drainage and Paving Improvements; setting a deadline for the bidder's execution of the contract and delivery of all bonds, insurance, and other required contract documents to the City; holding the bidder in default if it fails to meet the deadlines; providing funding for Testing, CIP Cost Recovery, Construction Management, and Contingencies relating to construction of facilities financed by the Street & Traffic Control and Storm Drainage DDSRF - **DISTRICT G - TRAVIS**

### **Background:**

**SUBJECT:** Contract Award for Yorkshire Area Drainage and Paving Improvements, WBS Nos. M-000247-0002-4.

### **RECOMMENDATION: (SUMMARY)**

Accept low bid, award Construction Contract and appropriate funds.

**PROJECT NOTICE/JUSTIFICATION:** This project is part of the Capital Improvements Program (CIP) and is required to resolve inadequate drainage system and reduce the potential for structural flooding.

**DESCRIPTION/SCOPE:** This project consists of construction of storm drainage improvements, necessary concrete paving, curbs, sidewalks, driveways and underground utilities. The Contract duration for this project is 420 calendar days. This project was designed by CivilTech Engineering, Inc.

**LOCATION:** The project area is generally bound by Memorial Drive on the north, Buffalo Bayou on the south, Regentview Street on the east and Kirkwood Road on the west. The project is located in Key Map Grids 489 E & F.

**BIDS:** This project was advertised for bidding on May 27, 2017. Bids were received on June 22, 2017. The five (5) bids are as follows:

	<u>Bidder</u>	<u>Bid Amount</u>
1.	SER Construction Partners, LLC	\$5,291,584.60
2.	Total Contracting Limited	\$5,439,683.30
3.	Resicom, Inc.	\$5,608,633.80
4.	Reytec Construction Resources, Inc	\$5,682,988.50
5.	Harber Brothers Construction. LLC	\$6,077,239.00

**AWARD:** It is recommended that this construction contract be awarded to SER Construction Partners, LLC with a low bid of \$5,291,584.60 and Addendum Numbers 1 and 2 be made a part of this Contract.

**PROJECT COST:** The total cost of this project is \$6,350,000.00 to be appropriated as follows:

· Bid Amount	\$5,291,584.60
· Contingencies	\$264,600.00
· Testing Services	\$175,000.00
· CIP Cost Recovery	\$218,815.40
· Construction Management	\$400,000.00

Testing Services will be provided by Professional Service Industries, Inc. under a previously approved contract.

Construction Management Services will be provided by TLC Engineering, Inc. under a previously approved contract.

**HIRE HOUSTON FIRST:** The proposed contract requires compliance with the City’s ‘Hire Houston First’ (HHF) ordinance that promotes economic opportunity for Houston business and supports job creation. In this case SER Construction Partners, LLC is a designated HHF company, but they were the successful awardee without application of the HHF preference.

**PAY OR PLAY PROGRAM:** The proposed contract requires compliance with the City’s ‘Pay or Play’ ordinance regarding health benefits for employees of City contractors. In this case, the Contractor provides health benefits to eligible employees in compliance with City policy.

**M/WSBE PARTICIPATION:** The contractor has submitted the following proposed program to satisfy the 11 % MBE goal and 7% WBE goal for this project.

	<u>MBE - Name of Firms</u>	<u>Work Description</u>	<u>Amount</u>	<u>% of Contract</u>
1.	Reliable Signal & Lightning Solutions, LLC	Electrical	\$ 122,500.00	2.31%
2.	PRV Services, Inc.	Concrete Paving	\$ 164,500.00	3.11%
3.	Bedo Construction Products, Inc.	Supply Pipe Products	\$ 295,500.00	5.58%
		<b>TOTAL</b>	<b>\$ 582,500.00</b>	<b>11.00%</b>

	<u>WBE - Name of Firms</u>	<u>Work Description</u>	<u>Amount</u>	<u>% of Contract</u>
1.	Deanie Hayes, Inc.	Supply Stabilized Sand	\$ 180,000.00	3.40%
		<b>TOTAL</b>	<b>\$ 180,000.00</b>	<b>3.40%</b>

	<u>SBE - Name of Firms</u>	<u>Work Description</u>	<u>Amount</u>	<u>% of Contract</u>
1.	Semarck Landscape Services, Inc.	Landscaping	\$ 194,500.00	3.68%
		<b>TOTAL</b>	<b>\$ 194,500.00</b>	<b>3.68%</b>

**ESTIMATED FISCAL OPERATING IMPACT:**

No significant Fiscal Operating impact is anticipated as a result of this project.

All known rights-of-way, easements and/or right-of-entry required for the project have been acquired.

---

Carol Ellinger Haddock, P.E.  
Acting Director  
Department of Public Works and Engineering

WBS No. M-000247-0002-4

**Amount of Funding:**

\$6,350,000.00 - Fund No. 4042-Street & Traffic Control and Storm Drainage DDSRF  
(\$6,350,000.00 Supported by Drainage Fee)

**Contact Information:**

Brian Alcott, P.E.  
Acting Senior Assistant Director, Capital Projects  
Phone: (832) 395-2396

**ATTACHMENTS:**

**Description**

Signed Coversheet  
Maps

**Type**

Signed Cover sheet  
Backup Material



**CITY OF HOUSTON - CITY COUNCIL**

Meeting Date:

District G

Item Creation Date: 8/15/2017

20RH04 Contract Award / SER Construction Partners

Agenda Item#:

**Summary:**

An ordinance appropriating the sum of \$6,350,000.00 out of the Street & Traffic Control and Storm Drainage DDSRF awarding a contract to SER Construction Partners, LLC. for Yorkshire Area Drainage and Paving Improvements; setting a deadline for the bidder's execution of the contract and delivery of all bonds, insurance, and other required contract documents to the city; holding the bidder in default if it fails to meet the deadlines; providing funding for Testing, CIP Cost Recovery, Construction Management, and Contingencies relating to construction of facilities financed by the Street & Traffic Control and Storm Drainage DDSRF; and declaring an emergency.

**Background:**

**SUBJECT:** Contract Award for Yorkshire Area Drainage and Paving Improvements, WBS Nos. M-000247-0002-4.

**RECOMMENDATION: (SUMMARY)**

Accept low bid, award Construction Contract and appropriate funds.

**PROJECT NOTICE/JUSTIFICATION:** This project is part of the Capital Improvements Program (CIP) and is required to resolve inadequate drainage system and reduce the potential for structural flooding.

**DESCRIPTION/SCOPE:** This project consists of construction of storm drainage improvements, necessary concrete paving, curbs, sidewalks, driveways and underground utilities. The Contract duration for this project is 420 calendar days. This project was designed by CivilTech Engineering, Inc.

**LOCATION:** The project area is generally bound by Memorial Drive on the north, Buffalo Bayou on the south, Regentview Street on the east and Kirkwood Road on the west. The project is located in Key Map Grids 489 E & F.

**BIDS:** This project was advertised for bidding on May 27, 2017. Bids were received on June 22, 2017. The five (5) bids are as follows:

Bidder	Bid Amount
1. SER Construction Partners, LLC	\$5,291,584.60
2. Total Contracting Limited	\$5,439,683.30
3. Resicom, Inc.	\$5,608,633.80
4. Reytec Construction Resources, Inc	\$5,682,988.50
5. Harper Brothers Construction, LLC	\$6,077,239.00

**AWARD:** It is recommended that this construction contract be awarded to SER Construction Partners, LLC with a low bid of \$5,291,584.60 and Addendum Numbers 1 and 2 be made a part of this Contract.

**PROJECT COST:** The total cost of this project is \$6,350,000.00 to be appropriated as follows:

· Bid Amount	\$5,291,584.60
· Contingencies	\$264,600.00
· Testing Services	\$175,000.00
· CIP Cost Recovery	\$218,815.40
· Construction Management	\$400,000.00

Testing Services will be provided by Professional Service Industries, Inc. under a previously approved contract.

Construction Management Services will be provided by TLC Engineering, Inc. under a previously approved contract.

**HIRE HOUSTON FIRST:** The proposed contract requires compliance with the City's 'Hire Houston First' (HHF) ordinance that promotes economic opportunity for Houston business and supports job creation. In this case SER Construction Partners, LLC is a designated HHF company, but they were the successful awardee without application of the HHF preference.

**PAY OR PLAY PROGRAM:** The proposed contract requires compliance with the City's 'Pay or Play' ordinance regarding health benefits for employees of City contractors. In this case, the Contractor provides health benefits to eligible employees in compliance with City policy.

**M/WSBE PARTICIPATION:** The contractor has submitted the following proposed program to satisfy the 11 % MBE goal and 7% WBE goal for this project.

<u>MBE - Name of Firms</u>	<u>Work Description</u>	<u>Amount</u>	<u>% of Contract</u>
1. Reliable Signal & Lightning Solutions, LLC	Electrical	\$ 122,500.00	2.31%
2. PRV Services, Inc.	Concrete Paving	\$ 164,500.00	3.11%
3. Bedo Construction Products, Inc.	Supply Pipe Products	\$ 295,500.00	5.58%
<b>TOTAL</b>		<b>\$ 582,500.00</b>	<b>11.00%</b>

<u>WBE - Name of Firms</u>	<u>Work Description</u>	<u>Amount</u>	<u>% of Contract</u>
1. Deanie Hayes, Inc.	Supply Stabilized Sand	\$ 180,000.00	3.40%
<b>TOTAL</b>		<b>\$ 180,000.00</b>	<b>3.40%</b>

<u>SBE - Name of Firms</u>	<u>Work Description</u>	<u>Amount</u>	<u>% of Contract</u>
1. Semarck Landscape Services, Inc.	Landscaping	\$ 194,500.00	3.68%
<b>TOTAL</b>		<b>\$ 194,500.00</b>	<b>3.68%</b>

**ESTIMATED FISCAL OPERATING IMPACT:**

No significant Fiscal Operating impact is anticipated as a result of this project.

All known rights-of-way, easements and/or right-of-entry required for the project have been acquired.

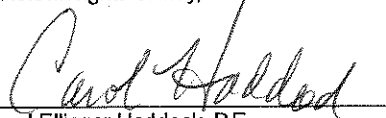

Carol Ellinger Haddock, P.E.  
Acting Director  
Department of Public Works and Engineering

WBS No. M-000247-0002-4

**Amount of Funding:**

\$6,350,000.00 - Fund No. 4042-Street & Traffic Control and Storm Drainage DDSRF  
(\$6,350,000.00 Supported by Drainage Fee)

**Contact Information:**

Brian Alcott, P.E.  
Acting Senior Assistant Director, Capital Projects  
Phone: (832) 395-2396

**ATTACHMENTS:**

<u>Description</u>	<u>Type</u>
Maps	Backup Material
Draft Ordinance	Backup Material
OBO Docs (HHF, Vendor Info Sheets & Letters of Intent)	Backup Material
Form A - Contractor's Submission List (doc 00452)	Backup Material
Form B - Fair Campaign Ord.	Backup Material
Affidavit of Ownership (doc 0455)	Backup Material
Tax Report	Backup Material
Pay or Play (POP 1-3)	Backup Material
Bid Extension Letter	Backup Material
Form 1295	Backup Material
SAP documents	Financial Information

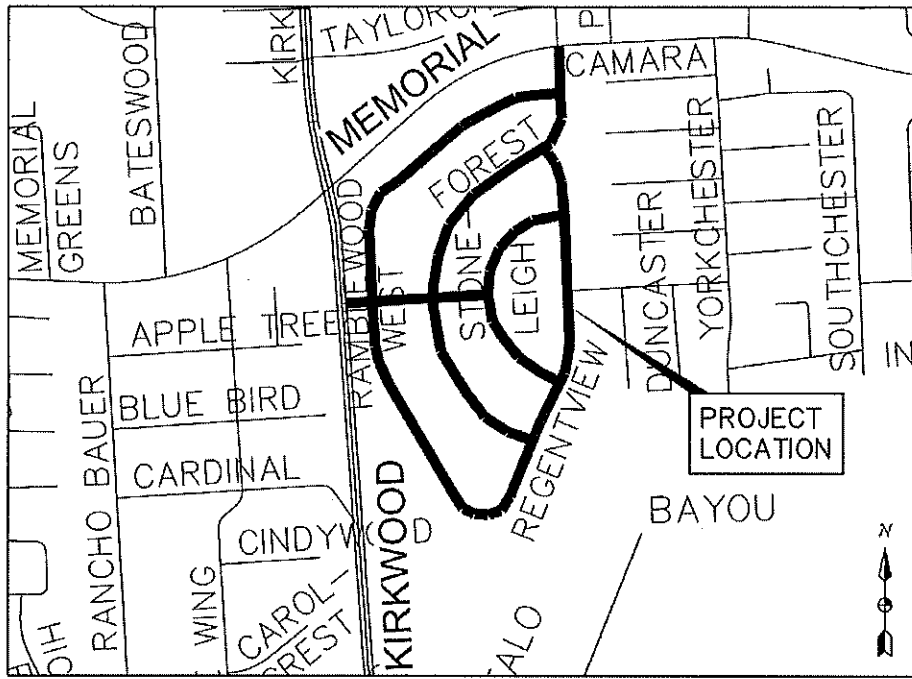

LOCATION MAP  
NTS

COUNCIL DISTRICT G  
KEY MAP NO. 489 E & F  
GIMS/WATER BLOCK MAP NO. 4857 B

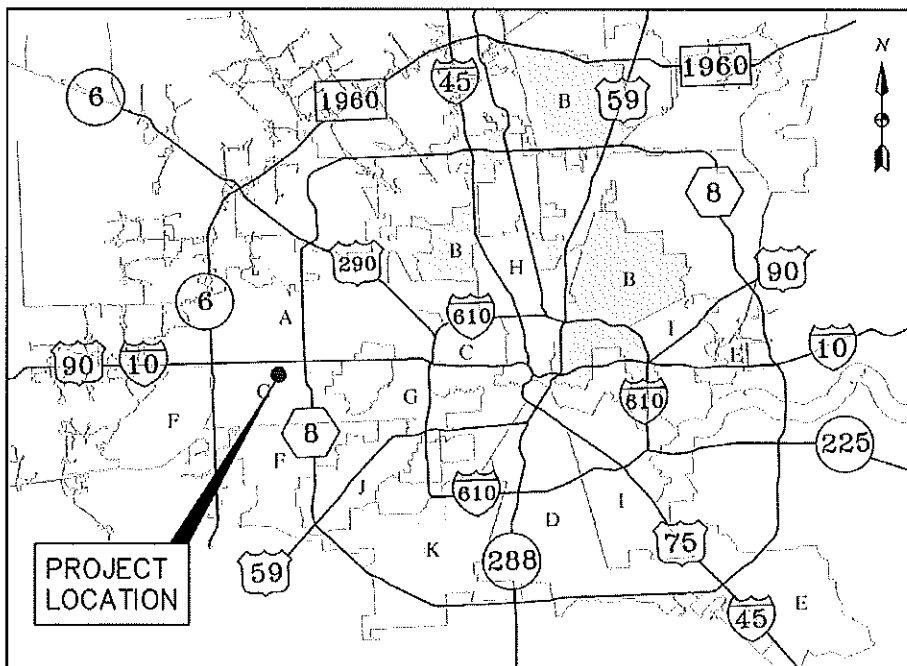

VICINITY MAP  
NTS

YORKSHIRE AREA DRAINAGE AND  
PAVING IMPROVEMENTS  
WBS NO. M-000247-0002-4

**CivilTech** 11821 Tedge Road  
Engineering, Inc. Cypress, Texas 77429  
(281) 304-0200 Fax (281) 304-0210  
Registration No. F-382



## CITY OF HOUSTON - CITY COUNCIL

Meeting Date: 11/8/2017

ALL

Item Creation Date: 10/17/2017

ARA-Abracadabra Septic Pumping LP SWF

Agenda Item#: 25.

### **Summary:**

ORDINANCE No. 2017-851 passed first reading November 1, 2017

ORDINANCE granting to **ABRACADABRA SEPTIC PUMPING, LP, a Texas Limited Partnership**, the right, privilege, and franchise to collect, haul and transport solid waste and industrial waste from commercial properties located within the City of Houston, Texas, pursuant to Chapter 39, Code of Ordinances, Houston, Texas; providing for related terms and conditions; and making certain findings related thereto - **SECOND READING**

### **Background:**

The Administration & Regulatory Affairs Department (ARA) recommends that City Council approve an ordinance granting a commercial solid waste operator franchise to Abracadabra Septic Pumping LP. Article VII of Chapter 39 of the City Code of Ordinances makes it unlawful for any commercial solid waste operator to collect, haul or transport solid waste or industrial waste from commercial properties located within the City without first having obtained a franchise for that purpose upon the consent of the City Council.

ARA's Franchise Administration Division collects franchise fees from commercial solid waste transporters, coordinates audits and compliance reviews and actively monitors state/federal legislation and administrative proceedings that impact these fees. The City currently has 228 solid waste operator franchises. For FY 2018, the total solid waste franchise revenue to the City is projected to be \$7,664,100.

The proposed ordinance grants the franchisee the right to use the City's public ways for the purpose of collecting, hauling or transporting solid or industrial waste from commercial properties located within the City of Houston. In consideration for this grant, each franchisee agrees to pay to the City an annual franchise fee equal to four percent of their annual gross revenue, payable quarterly. To verify franchisee compliance with the franchise, the franchisee company has the duty to maintain required customer records, which the City has the right to inspect during regular business hours. The franchise agreement contains the City's standard release and indemnification, default and termination, liquidated damages and force majeure provisions. The proposed franchise term is 10 years from the effective date.

### **Departmental Approval Authority:**

---

**Tina Paez, Director**  
**Administration & Regulatory Affairs Department**

**Other Authorization**

**Contact Information:**

Lara Cottingham                      **Phone:** (832) 393- 8503  
Naelah Yahya                         **Phone:** (832) 393- 8530

**ATTACHMENTS:**

<b>Description</b>	<b>Type</b>
10.17.2017 Abracadabra Septic Pumping LP SWF RCA.pdf	Signed Cover sheet



**CITY OF HOUSTON - CITY COUNCIL**

Meeting Date: 10/31/2017

ALL

Item Creation Date: 10/17/2017

ARA- Abracadabra Septic Pumping LP SWF

**Background:**

The Administration & Regulatory Affairs Department (ARA) recommends that City Council approve an ordinance granting a commercial solid waste operator franchise to Abracadabra Septic Pumping LP. Article VII of Chapter 39 of the City Code of Ordinances makes it unlawful for any commercial solid waste operator to collect, haul or transport solid waste or industrial waste from commercial properties located within the City without first having obtained a franchise for that purpose upon the consent of the City Council.

ARA's Franchise Administration Division collects franchise fees from commercial solid waste transporters, coordinates audits and compliance reviews and actively monitors state/federal legislation and administrative proceedings that impact these fees. The City currently has 228 solid waste operator franchises. For FY 2018, the total solid waste franchise revenue to the City is projected to be \$7,664,100.

The proposed ordinance grants the franchisee the right to use the City's public ways for the purpose of collecting, hauling or transporting solid or industrial waste from commercial properties located within the City of Houston. In consideration for this grant, each franchisee agrees to pay to the City an annual franchise fee equal to four percent of their annual gross revenue, payable quarterly. To verify franchisee compliance with the franchise, the franchisee company has the duty to maintain required customer records, which the City has the right to inspect during regular business hours. The franchise agreement contains the City's standard release and indemnification, default and termination, liquidated damages and force majeure provisions. The proposed franchise term is 10 years from the effective date.

**Departmental Approval Authority:**

A handwritten signature in black ink, appearing to read "Tina Paez".

---

**Tina Paez, Director  
Administration & Regulatory  
Affairs Department**

**Other Authorization**

**Contact Information:**

Lara Cottingham      Phone: (832) 393-8503  
Naelah Yahya        Phone: (832) 393-8530



## CITY OF HOUSTON - CITY COUNCIL

Meeting Date: 11/8/2017

District A, District B, District C, District D, District E, District F, District G, District I, District J, District K

Item Creation Date:

20DWO06 - Accept Work for Fire Hydrant Replacement Project

Agenda Item#: 26.

### **Summary:**

RECOMMENDATION from Acting Director Department of Public Works & Engineering for approval of final contract amount of \$1,577,278.62 and acceptance of work on contract with **CES UTILITIES, INC** for Fire Hydrant Replacement Project - 8.37% under the original contract amount (WA11180) - **DISTRICTS A - STARDIG; B - DAVIS; C - COHEN; D - BOYKINS; E - MARTIN; F - LE; G - TRAVIS; I - GALLEGOS; J - LASTER and K - GREEN**

**TAGGED BY COUNCIL MEMBER GREEN**

This was Item 4 on Agenda of November 1, 2017

### **Background:**

**SUBJECT:** Accept Work for Fire Hydrant Replacement Project

WBS No. S-000035-0235-4, File No. WA 11180

### **RECOMMENDATION: (Summary)**

Pass a motion to approve the final contract amount of \$1,577,278.62 or 8.37% under the original contract amount, accept the work, and authorize final payment.

### **SPECIFIC EXPLANATION:**

**PROJECT NOTICE/JUSTIFICATION:** Under this project, the contractor provided a work order based installation of damaged or irreparable fire hydrants throughout the City.

**DESCRIPTION/SCOPE:** This project provided for the replacement of fire hydrants and valves, the height correction of fire hydrants, and the relocation of fire hydrants and ancillary work. The project was awarded to CES Utilities, Inc. with an original contract amount of \$1,721,339.15. The Notice to Proceed date was 02/10/15 and the project had 365 calendar days for completion.

**LOCATION:** The work performed under the contract included locations within Council Districts A, B, C, D, E, F, G, H, I, J and K.

**CONTRACT COMPLETION AND COST:** The contractor CES Utilities, Inc. has completed the work under the contract. The project was completed with an additional 30 days by Change Order No. 1. The final cost of the project, including overrun and underrun of estimated bid is \$1,577,278.62, a decrease of \$144,060.53 or 8.37% under the original contract amount.

**MWBE PARTICIPATION:** The contract MBE and WBE Goals were 12% and 8% respectively. According to Office of Business Opportunity, the actual participation was 10.39%. The contractor was awarded an “Unsatisfactory” rating.

---

Carol Ellinger Haddock, P.E.  
Acting Director  
Department of Public Works and Engineering

**Prior Council Action:**

Ordinance No. 2014-0985, dated 11/05/14

**Amount of Funding:**

No additional funding is required. Original appropriation of \$1,837,406.11 from the Water and Sewer System Operating Fund No. 8500.

**Contact Information:**

Ravi Kaleyatodi, P.E.,  
Acting Senior Assistant Director  
Phone:(832) 395-2326

**ATTACHMENTS:**

**Description**

Signed Coversheet

**Type**

Signed Cover sheet



## CITY OF HOUSTON - CITY COUNCIL

Meeting Date:

District A, District B, District C, District D, District E, District F, District G, District I, District J, District K

Item Creation Date:

20DWO06 - Accept Work for Fire Hydrant Replacement Project

Agenda Item#:

### **Background:**

**SUBJECT:** Accept Work for Fire Hydrant Replacement Project

WBS No. S-000035-0235-4, File No. WA 11180

### **RECOMMENDATION: (Summary)**

Pass a motion to approve the final contract amount of \$1,577,278.62 or 8.37% under the original contract amount, accept the work, and authorize final payment.

### **SPECIFIC EXPLANATION:**

**PROJECT NOTICE/JUSTIFICATION:** Under this project, the contractor provided a work order based installation of damaged or irreparable fire hydrants throughout the City.

**DESCRIPTION/SCOPE:** This project provided for the replacement of fire hydrants and valves, the height correction of fire hydrants, and the relocation of fire hydrants and ancillary work. The project was awarded to CES Utilities, Inc. with an original contract amount of \$1,721,339.15. The Notice to Proceed date was 02/10/15 and the project had 365 calendar days for completion.

**LOCATION:** The work performed under the contract included locations within Council Districts A, B, C, D, E, F, G, H, I, J and K.

**CONTRACT COMPLETION AND COST:** The contractor CES Utilities, Inc. has completed the work under the contract. The project was completed with an additional 30 days by Change Order No. 1. The final cost of the project, including overrun and underrun of estimated bid is \$1,577,278.62, a decrease of \$144,060.53 or 8.37% under the original contract amount.

**MWBE PARTICIPATION:** The contract MBE and WBE Goals were 12% and 8% respectively. According to Office of Business Opportunity, the actual participation was 10.39%. The contractor was awarded an "Unsatisfactory" rating.

Carol Ellinger Haddock, P.E.

Acting Director

Department of Public Works and Engineering

### **Prior Council Action:**

Ordinance No. 2014-0985, dated 11/05/14

### **Amount of Funding:**

No additional funding is required. Original appropriation of \$1,837,406.11 from the Water and Sewer System Operating Fund No. 8500.

### **Contact Information:**

Ravi Kaleyatodi, P.E.,

Acting Senior Assistant Director

Phone:(832) 395-2326

### **ATTACHMENTS:**

#### **Description**

City Map

Final Pay Estimate

Prior Ordinance and RCA

Change Order No. 1

Final Audit Summary by OBO

#### **Type**

Backup Material

Backup Material

Backup Material

Backup Material

Backup Material

Certificates of Final Completion

Contract Evaluation by DWO

Contract Closeout by OBO

Request for Closing of Contract

Tax Report

Work Order Report with Council Districts

Backup Material

Backup Material

Backup Material

Backup Material

Backup Material

Backup Material



**CITY OF HOUSTON - CITY COUNCIL**

Meeting Date: 11/8/2017

ALL

Item Creation Date: 10/5/2017

S26257 - Cummins Replacement Parts & Repair Services-MOTION

Agenda Item#: 27.

**Summary:**

MOTION by Council Member Cohen/Seconded by Council Member Knox to adopt recommendation from Chief Procurement Officer, to award to **RUSH TRUCK CENTERS OF TEXAS, LP** for Cummins replacement parts and repair services for the Fleet Management Department - 3 Years with two one-year options - \$6,388,814.00 - Fleet Management Fund

**TAGGED BY COUNCIL MEMBERS GREEN and BOYKINS**

This was Item 5 on Agenda of November 1, 2017

**Background:**

**Formal Bids Received for S40-S26257 - Approve an award to Rush Truck Centers of Texas, LP in an amount not to exceed \$6,388,814.00 for Cummins replacement parts and repair services for the Fleet Management Department.**

**Specific Explanation:**

The Director of the Fleet Management Department and the Chief Procurement Officer recommend that City Council approve an award to **Rush Truck Centers of Texas, LP** on its low complete bid meeting specification in an amount not to exceed **\$6,388,814.00** for Cummins replacement parts and repair services for the Fleet Management Department (FMD). It is further requested that authorization be given to make purchases, as needed, for a **thirty-six month term with two (2) one-year options**. This award consists of price lists for various Cummins replacement parts; which includes but are not limited to belt tensioners, fuel check valves, transfer pumps, water pumps, EGR coolers, starting motors, solenoids, oxygen sensors, wiring harnesses, fuel injectors, fuel pumps, reconditioned engines and engine blocks. These materials will be used by FMD to repair and maintain equipment with Cummins engines citywide. This award also includes a **\$1,596,950.00** labor component for the repair of equipment that cannot be performed by City maintenance personnel.

This is a price list and line item award. Relative to the price list, the best discount which determines the low bid for a price list is the best bid received for quantities of high-use items selected as sample pricing items based on the current needs of the department. The bid total for sample pricing items does not represent the total amount estimated to be purchased; rather, this recommendation is for the total estimated expenditures projected over the awarded term based on the low bid submitted for the representative samples.

This project was advertised in accordance with the State of Texas bid laws. Five prospective bidders downloaded the solicitation document from SPD's e-bidding website, and four bids were received as outlined below.

**Rush Truck Centers of Texas, LP:** Award on its low complete bid meeting specifications for Groups 1 - 6 in an amount not to exceed \$6,388,814.00.

<u>Company</u>	<u>Sample Pricing &amp; Line Item Total</u>
1. Homer J. Wood	\$ 620.50 (Partial Bid/Did Not Meet Specifications)
2. Southern Tire Mart, LLC	\$ 919,445.83 (Partial Bid/Did Not Meet Specifications)
3. <b>Rush Truck Centers of Texas, LP</b>	<b>\$1,672,574.96</b>
4. Cummins Southern Plains, LLC	\$2,218,629.16

**MWBE:**

Zero-percentage goal document approved by the Office of Business Opportunity.

**Hire Houston First:**

The proposed award requires compliance with the City's 'Hire Houston First' (HHF) ordinance that promotes economic opportunity for Houston businesses and supports job creation. In this case, the proposed supplier does not meet the requirements of HHF; no HHF firms were within three percent.

**Fiscal Note:**

Fiscal Note: This item is funded by the Fleet Management Department. The total estimated cost of this award is \$6,388,814.00. The award is for a three-year term with two one-year options. The award is for the Fleet Management Department. The award is for the Fleet Management Department.

Funding for this item is included in the FY18 Adopted Budget. Therefore, no fiscal note is required as stated in the Financial Policy Ord. 2014-1078.

---

**Jerry Adams, Chief Procurement Officer**  
**Finance/Strategic Procurement Division**

---

**Department Approving Authority**

**Estimated Spending Authority**

<b>Department</b>	<b>FY18</b>	<b>Out Years</b>	<b>Total</b>
Fleet Management	\$1,277,762.80	\$5,111,051.20	\$6,388,814.00

**Amount of Funding:**

\$6,388,814.00 - Fleet Management Fund (1005)

**Contact Information:**

Desiree Heath      SPD      (832) 393-8742  
Jeff Meekins      SPD      (832) 393-8743  
Jedediah Greenfield      FMD      (832) 393-6910

**ATTACHMENTS:**

**Description**

Cover Sheet  
OBO DOCS

**Type**

Signed Cover sheet  
Backup Material



## CITY OF HOUSTON - CITY COUNCIL

Meeting Date:

ALL

Item Creation Date: 10/5/2017

S26257 - Cummins Replacement Parts & Repair Services

Agenda Item#:

### Background:

**Formal Bids Received for S40-S26257 - Approve an award to Rush Truck Centers of Texas, LP in an amount not to exceed \$6,388,814.00 for Cummins replacement parts and repair services for the Fleet Management Department.**

### Specific Explanation:

The Director of the Fleet Management Department and the Chief Procurement Officer recommend that City Council approve an award to **Rush Truck Centers of Texas, LP** on its low complete bid meeting specification in an amount not to exceed **\$6,388,814.00** for Cummins replacement parts and repair services for the Fleet Management Department (FMD). It is further requested that authorization be given to make purchases, as needed, for a **thirty-six month term with two (2) one-year options**. This award consists of price lists for various Cummins replacement parts; which includes but are not limited to belt tensioners, fuel check valves, transfer pumps, water pumps, EGR coolers, starting motors, solenoids, oxygen sensors, wiring harnesses, fuel injectors, fuel pumps, reconditioned engines and engine blocks. These materials will be used by FMD to repair and maintain equipment with Cummins engines citywide. This award also includes a **\$1,596,950.00** labor component for the repair of equipment that cannot be performed by City maintenance personnel.

This is a price list and line item award. Relative to the price list, the best discount which determines the low bid for a price list is the best bid received for quantities of high-use items selected as sample pricing items based on the current needs of the department. The bid total for sample pricing items does not represent the total amount estimated to be purchased; rather, this recommendation is for the total estimated expenditures projected over the awarded term based on the low bid submitted for the representative samples.

This project was advertised in accordance with the State of Texas bid laws. Five prospective bidders downloaded the solicitation document from SPD's e-bidding website, and four bids were received as outlined below.

**Rush Truck Centers of Texas, LP:** Award on its low complete bid meeting specifications for Groups 1 - 6 in an amount not to exceed \$6,388,814.00.

	<u>Company</u>	<u>Sample Pricing &amp; Line Item Total</u>
1.	Homer J. Wood	\$ 620.50 (Partial Bid/Did Not Meet Specifications)
2.	Southern Tire Mart, LLC	\$ 919,445.83 (Partial Bid/Did Not Meet Specifications)
3.	<b>Rush Truck Centers of Texas, LP</b>	<b>\$1,672,574.96</b>
4.	Cummins Southern Plains, LLC	\$2,218,629.16

### MWBE:

Zero-percentage goal document approved by the Office of Business Opportunity.

### Hire Houston First:

The proposed award requires compliance with the City's 'Hire Houston First' (HHF) ordinance that promotes economic opportunity for Houston businesses and supports job creation. In this case, the proposed supplier does not meet the requirements of HHF; no HHF firms were within three percent.

### Fiscal Note:

Funding for this item is included in the FY18 Adopted Budget. Therefore, no fiscal note is required as stated in the Financial Policy Ord. 2014-1078.

  
 Jerry Adams, Chief Procurement Officer  
 Finance/Strategic Procurement Division

Department Approving Authority Signature

**Estimated Spending Authority**

Department	FY18	Out Years	Total
Fleet Management	\$1,277,762.80	\$5,111,051.20	\$6,388,814.00

**Amount of Funding:**

\$6,388,814.00 - Fleet Management Fund (1005)

**Contact Information:**

Desiree Heath      SPD      (832) 393-8742  
 Jeff Meekins      SPD      (832) 393-8743  
 Jedediah Greenfield      FMD      (832) 393-6910

**ATTACHMENTS:**

**Description**

OBO DOCS

FAIR CAMPAIGN

DELINQUENT TAX

BID TAB

FORM B

BUDGET FORM A

**Type**

Backup Material

Backup Material

Backup Material

Backup Material

Backup Material

Financial Information

Jan 12/2017

NOTE: SEE INCREASED AMOUNT ON p. 2 of this document

RECEIVED



CITY OF HOUSTON OFFICE BUSINESS OPPORTUNITY

Goal Modification Request Form

1. Date: 02/27/2017 2. Requesting Department: Fleet Management Department 3. Solicitation Number: S26169 526257

4. Solicitation Name: Cummins Replacement Parts & Repair Services 5. Estimated Dollar Amount: \$3,726,411.60

OK [Signature]

Description of Solicitation (Attach Specifications/Supporting Documents): Parts and repair services for Cummins engines in City of Houston vehicles and equipment.

PLEASE INDICATE WHETHER A PREVIOUS CONTRACT EXISTED FOR THIS SOLICITATION.

- A. Previous Contract (if any): Yes [X] No [ ] B. Previous Contract #: S23215 C. Goal on Last Contract: 0% D. Was Goal Met? Yes [ ] No [ ] E. If goal was not met, what percentage did the vendor achieve? F. Why wasn't goal achieved:

SELECT ONE TYPE OF GOAL MODIFICATION REQUEST FROM THE FOUR OPTIONS BELOW.

1. WAIVER

- A. I am requesting a waiver of the MWBE Goal: Yes [X] No [ ] B. Reason for waiver: (Check One)

- [ ] A public or administrative emergency exists which requires the goods or services to be provided with unusual immediacy [ ] If goods and services are specialized, technical or unique nature as to require the City department to select its contractor without application of MWSBE provisions (such as contracts for expert witnesses, certain financial advisors or technical consultants); [ ] MWSBE provisions impose an unwarranted economic burden or risk on the City or unduly delay acquisition of the goods or services, or is not in the best interest of the City; or [ ] Level of MWSBE availability would produce minimal MWSBE participation. [X] Other:

C. Detailed Explanation for Waiver Reason: The Cummins Parts and Services are considered specialty parts and assigned to authorized dealers with in the Houston Area. The vast majority of parts are being directed shipped from the regional office to the consumer(s).

2. COOPERATIVE OR INTER-LOCAL AGREEMENT

- A. Is this a Cooperative/Inter-Local Agreement? Yes [ ] No [ ] B. If yes, please specify the name of the Agreement: C. Did the Department explore opportunities for using certified firms? Yes [ ] No [ ] D. Please explain how the Department explored opportunities for using certified firms: E. Please explain why the Department did not explore opportunities for using certified firms:

(OVER)



**CITY OF HOUSTON**  
OFFICE  
BUSINESS OPPORTUNITY

**Goal Modification  
Request Form**

**3. REDUCED GOAL (To be completed by the department prior to advertisement)**

A. I am requesting a MWBE contract-specific goal below the following citywide goals:

Construction (34%); Professional Services (24%); Purchasing (11%)

Yes  No  If yes, complete a Contract-Specific Goal Request Form and submit with this form.

**4. GOAL REVISION AFTER ADVERTISEMENT**

A. I am requesting a revision of the MWBE Goal that has already been advertised: Yes  No

B. Original Goal: \_\_\_\_\_ C. New Proposed Goal: \_\_\_\_\_ D. Advertisement Date: \_\_\_\_\_

E. Will Project be Re-Advertised: Yes  No  F. Estimated Dollar Amount: \$ \_\_\_\_\_

G. Detailed reason for request: \_\_\_\_\_

Concurrence:

Brian H. York  
Requesting Department Initials

2-24-17  
Date

[Signature]  
Department Director or Designee

2/27  
Date

**FOR OBO OFFICE USE ONLY:**

**APPROVED:**

\*

<u>Heather Henry</u>	<u>3/7/17</u>	<u>NON-DIVISIBLE</u>	<u>W-729</u>
OBO Assistant Director or Designee	Date	OBO Reason	Tracking #

**DENIED:**

OBO Assistant Director or Designee	Date	OBO Reason	Tracking #

\* 8/4/17 Increase in dollar amount does not impact the non-divisibility of this contract.

New Amount - \$6,389,152.00