

AGENDA

CITY OF HOUSTON ■ CITY COUNCIL
October 25 & 26, 2016

MAYOR
SYLVESTER TURNER

CONTROLLER
CHRIS B. BROWN

DISTRICT COUNCIL MEMBERS

Brenda Stardig
District A

Steve Le
District F

Jerry Davis
District B

Greg Travis
District G

Ellen R. Cohen
District C

Karla Cisneros
District H

Dwight A. Boykins
District D

Robert Gallegos
District I

Dave Martin
District E

Mike Laster
District J

Larry V. Green
District K

AT-LARGE COUNCIL MEMBERS

Mike Knox
Position 1

Michael Kubosh
Position 3

David W. Robinson
Position 2

Amanda K. Edwards
Position 4

Jack Christie D.C.
Position 5

Marta Crinejo Director - City Council Agenda

Anna Russell City Secretary

In accordance with the Texas Open Meetings Act the agenda is posted for public information, at all times, for at least 72 hours preceding the scheduled time of the meeting on the bulletin board located on the exterior wall of the City Hall building at 901 Bagby.

The agenda may be accessed via the Internet at

<http://houston.novusagenda.com/agendapublic/>. Copies of the agenda are available in the Office of the City Secretary in the City Hall Annex, Public Level at no charge. To receive the agenda by mail, send check or money order for \$52.00 for a one year subscription, made payable to the City of Houston to the attention of the City Secretary, P.O. Box 1562, Houston, Texas 77251.

To reserve time to appear before Council call 832-393-1100 or come to the Office of the City Secretary, City Hall Annex, Public Level at least 30 minutes prior to the scheduled public session shown on the agenda.

NOTE: If a translator is required, please advise when reserving time to speak

AGENDA - COUNCIL MEETING Tuesday, October 25, 2016 - 1:30 PM
COUNCIL CHAMBER - SECOND FLOOR - CITY HALL

PRESENTATIONS

2:00 P.M. – INVOCATION AND PLEDGE OF ALLEGIANCE

Council Member Gallegos

ROLL CALL AND ADOPT MINUTES OF PREVIOUS MINUTES

PUBLIC SPEAKERS - Pursuant to City Council Rule 8, City Council will hear from members of the public; the names and subject matters of persons who had requested to speak at the time of posting this Agenda are attached; the names and subject matters of persons who subsequently request to speak may be obtained in the City Secretary's Office.

NOTE: If a translator is required, please advise when reserving time to speak

SP102516

RECESS

RECONVENE

WEDNESDAY - October 26, 2016 - 9:00 A. M.

DESCRIPTIONS OR CAPTIONS OF AGENDA ITEMS WILL BE READ BY THE
CITY SECRETARY PRIOR TO COMMENCEMENT

HEARINGS

1. **PUBLIC HEARING** regarding just and reasonable rates to be observed within the City of Houston relating to the Retail Water and Sewer Rates of **NITSCH AND SON UTILITY COMPANY, INC - DISTRICT H - CISNEROS**

MAYOR'S REPORT

CONSENT AGENDA NUMBERS 2 through 43

MISCELLANEOUS - NUMBERS 2 through 4

2. REQUEST from Mayor for confirmation of the appointment or reappointment of the following individuals to **REINVESTMENT ZONE NUMBER NINE, CITY OF HOUSTON, TEXAS (SOUTH POST OAK ZONE) BOARD OF DIRECTORS**:

Position Three - **ALGENITA SCOTT DAVIS**, reappointment, for a term to expire 12/31/2017, and to serve as Chair for a term ending 12/31/2016

Position Four - **PAUL E. JEFFERSON**, appointment, for a term to expire 2/31/2017

Position Five - **TANDELYN ATKINSON WEAVER**, reappointment, for a term to expire 12/31/2017

3. RECOMMENDATION from Director of Aviation to extend unpaid leave of absence for **MARTHA GONZALEZ**, Semi-Skilled Laborer
4. RECOMMENDATION from Director of Aviation to extend unpaid leave of absence for **GREGG PHIPPS**, Operations Coordinator

ACCEPT WORK - NUMBERS 5 through 8

5. RECOMMENDATION from Director Department of Public Works & Engineering for approval of final contract amount of \$665,703.95 and acceptance of work on contract with **IU-FEI SAFE SIDEWALK JV** for Safe Sidewalk Program - 7.25% under the original contract amount - **DISTRICTS B - DAVIS; E - MARTIN; F - LE and I - GALLEGOS**
6. RECOMMENDATION from Director Department of Public Works & Engineering for approval of final contract amount of \$8,369,060.27 and acceptance of work on contract with **CSA CONSTRUCTION, INC** for FWSD No. 23 Wastewater Treatment Plant Improvements - 7.00% under the original contract amount - **DISTRICT B - DAVIS**
7. RECOMMENDATION from Director Department of Public Works & Engineering for approval of final contract amount of \$843,879.03 and acceptance of work on contract with **C. F. MCDONALD ELECTRIC, INC** for Generator Relocation from Southwest Wastewater Treatment Plant to Northwest Wastewater Treatment Plant - 1.13% over the original contract amount and under 5% contingency amount - **DISTRICT A - STARDIG**
8. RECOMMENDATION from Director Department of Public Works & Engineering for approval of final contract amount of \$4,246,345.47 and acceptance of work on contract with **S.J. LOUIS CONSTRUCTION OF TEXAS LTD.** for 42- inch Water Line along Bellaire Boulevard from Bellaire Braes Pump Station to South Kirkwood Road - 0.25% under the original contract amount - **DISTRICT F - LE**

PROPERTY - NUMBER 9

9. RECOMMENDATION from City Attorney to deposit the amount of the Award of Special Commissioners into the Registry of the Court and pay the costs of court and settle the case in connection with eminent domain proceedings styled City of Houston v. Parkwood Baptist Church, a Texas non-profit

corporation, et al, Cause No. 1065634; for acquisition of Parcel KY14-069; for the **NORTHEAST TRANSMISSION 108-INCH WATER LINE EASEMENT ACQUISITION PROJECT (LEE RD - VICKERY DR.) - DISTRICT B - DAVIS**

PURCHASING AND TABULATION OF BIDS - NUMBERS 10 through 13

10. **ADVANCED PUBLIC SAFETY** for Software Maintenance and Support Services for the Electronic Citation Software PocketCitation™ for the Houston Police Department - 1 Year \$143,769.59 - General Fund
11. **INFOR PUBLIC SECTOR, INC** for approval of spending authority in the amount not to exceed \$995,000.00 for purchase of Professional Services for Department of Public Works & Engineering Enterprise and Other Funds
12. ORDINANCE appropriating \$37,826.00 out of Fleet Equipment Special Revenue Fund for the purchase of Transit and Cargo Vans for the Fleet Management Department
13. **SILSBEE FORD, INC** - \$424,354.33, **CALDWELL AUTOMOTIVE PARTNERS LLC, D/B/A CALDWELL COUNTRY CHEVROLET, LLC** - \$175,370.00, **COWBOY DODGE** - \$201,840.01, for Transit and Cargo Vans through the Interlocal Agreement for Cooperative Purchasing with the Houston-Galveston Area Council and the Texas Local Government Purchasing Cooperative (BuyBoard) for Various Departments - \$801,564.34 - Equipment Acquisition Consolidated, Fleet Equipment Special Revenue Fund and Other Funds

This item should only be considered after passage of Item 12 above

RESOLUTIONS - NUMBER 14

14. RESOLUTION in support of the City's plan to reform the City's three Pension Systems, the Houston Police Officers' Pension System, the Houston Municipal Employees Pension System, and the Houston Firefighters' Relief and Retirement Fund, to ensure long-term, secure, and dependable retirement systems

ORDINANCES - NUMBERS 15 through 43

15. ORDINANCE approving and authorizing amendment to Legislature Issues Provision of the 2011 Meet and Confer Agreement between the City of Houston and the **HOUSTON POLICE OFFICERS' PENSION SYSTEM**
16. ORDINANCE **AMENDING CHAPTER 41 OF THE CODE OF ORDINANCES, HOUSTON, TEXAS**, relating to street naming; making conforming amendments to other chapters of the Code of Ordinances
17. ORDINANCE **AMENDING ARTICLE XII OF CHAPTER 47 OF THE CODE OF ORDINANCES, HOUSTON, TEXAS**, including the repeal of Sections 47-674 and 47-675; relating to Storm Water Discharge; containing findings and other provisions relating to the foregoing subject, providing for severability; declaring an effective date

18. ORDINANCE amending the City of Houston Construction Code by adopting a revised Commercial Energy Conservation Code based on the 2015 International Energy Conservation Code—Commercial Provisions and the American Society of Heating, Refrigeration and Air Conditioning Engineers Standard 90.1-2013; containing findings and other provisions relating to the foregoing subject; containing a repealer; containing a savings clause; providing an effective date; providing for severability
19. ORDINANCE finding and determining that public convenience and necessity no longer require the continued use of Castlebay Street, from the east right-of-way line of Burr Oak Street east to the east property line of the remaining portion of Lot 13, Block 6 and a 10 foot-wide prescriptive water line easement, in the former Belmore Street, from the south right-of-way line west Tidwell Road south 35 feet, located in the Rosslyn Subdivision, out of the Joseph Bays Survey, A-127, Houston, Texas; vacating and abandoning the street to Contempo Builder LLC, abutting owner, in consideration of the payment of \$173,580.00 to the City and other consideration - **DISTRICT A - STARDIG**
20. ORDINANCE approving and authorizing the Director of the City of Houston Health Department to accept continuation grant funds from the U.S. Department of Health and Human Services, Centers for Disease Control and Prevention, for the City's HIV Prevention Activities; declaring the City's eligibility for such grant; authorizing the Director to expend the grant funds, as awarded, and to apply for and accept all subsequent awards, if any, pertaining to the grant
21. ORDINANCE approving and authorizing amendment to Loan Agreement between the City of Houston and **AVENUE COMMUNITY DEVELOPMENT CORPORATION**, to provide a Performance-Based Loan of an additional \$481,135.00 of Federal Community Block Grant Disaster Relief Program – Rental Housing Projects Round 2 Funds to assist with construction of a 68 unit Mixed-Income Apartment Development, including 52 affordable units, located in Houston, Texas, near 2010 North Main Street - **DISTRICT H - CISNEROS**
22. ORDINANCE approving and authorizing first amendment to contract between the City of Houston and **BRENTWOOD ECONOMIC COMMUNITY DEVELOPMENT CORP., doing business as BRENTWOOD COMMUNITY FOUNDATION**, extending the term of the contract and providing up to \$551,607.75 in Housing Opportunities for Persons with AIDS Funds for the continuing administration and operation of a community residence and the administration of a Short-Term Rent, Mortgage and Utility Assistance Program, along with supportive services
23. ORDINANCE approving and authorizing first amendment to contract between the City of Houston and **CATHOLIC CHARITIES OF THE ARCHDIOCESE OF GALVESTON-HOUSTON** extending the term of the contract and providing up to an additional \$995,166.75 in Housing Opportunities for Persons with AIDS Funds for the continuing administration and operation of a tenant-based rental assistance program, a short-term rent, mortgage, and utility assistance program, and the provision of other supportive services
24. ORDINANCE approving and authorizing first amendment to contract between the City of Houston and **HOUSTON SRO HOUSING CORPORATION** to extend the term of the contract and provide up to \$141,365.00 in Housing

Opportunities for Persons With AIDS Funds for the operation of a Single Room Occupancy/Community Residence and the provision of other supportive services

25. ORDINANCE approving and authorizing first amendment to contract between the City of Houston and **SEARCH HOMELESS SERVICES formerly SERVICE OF THE EMERGENCY AID RESOURCE CENTER FOR THE HOMELESS, INC**, to extend the term of the contract and provide up to \$144,551.00 in Housing Opportunities for Persons With AIDS Funds for the continuing administration and operation of a Supportive Services Program offering childcare for homeless families affected by HIV/AIDS
26. ORDINANCE approving and authorizing Lease Agreement between the City of Houston and **BPM AIRPORT, LLC**, for certain premises at William P. Hobby Airport - **DISTRICT I - GALLEGOS**
27. ORDINANCE amending Ordinance 2016-755 calling public hearings at which interested persons will be given the opportunity to be heard on: proposed amendments to the Strategic Partnership Agreements between the City of Houston and **FORT BEND COUNTY MUNICIPAL UTILITY DISTRICT NO. 142** and **MONTGOMERY COUNTY UTILITY DISTRICT NO. 119** and on a proposal to annex for limited purposes territory located within and in the vicinity of such districts in Fort Bend and Montgomery Counties; proposed amendments to Strategic Partnership Agreements between the City of Houston and **LAKE FOREST UTILITY DISTRICT, REID ROAD MUNICIPAL UTILITY DISTRICT NO. 1, and TRAIL OF THE LAKES MUNICIPAL UTILITY DISTRICT** and on proposals for the City of Houston to annex for limited purposes certain territory located within such districts in Harris County; proposals of the City of Houston to impose the City of Houston's Sales and Use Tax in such territories; providing for the publication of notice of such hearings - **DISTRICTS A - STARDIG; E - MARTIN and F - LE HEARING DATES - 9:00 A.M. - WEDNESDAY - NOVEMBER 9 and 16, 2016**
28. ORDINANCE amending Ordinance No. 2005-0619, as amended, to increase the maximum contract amount for agreement for Professional Legal Services (Contract No. C56949) between the City and **CLARENCE A. WEST, ATTORNEY AT LAW**
29. ORDINANCE establishing the north side of the 1400 block of Michigan Street, within the City of Houston as a special minimum lot size block pursuant to Chapter 42 of the Code of Ordinances, Houston, Texas - **DISTRICT C - COHEN**
30. ORDINANCE approving and authorizing contract between the City and **MUNISERVICES, LLC** for Sales/Use Tax Audit and Sales/Use Tax Analysis and Reporting Services; providing a maximum contract amount - 3 Years with 2 one-year options - \$3,150,000.00 - General Fund
31. ORDINANCE approving and authorizing fourth amendment to the Pay Connexion Service Terms Contract, as amended, between the City and **JPMORGAN CHASE BANK, N.A.** to provide for additional Credit Card Transaction Services for the Houston Permitting Center and the Houston Airport System
32. ORDINANCE approving and authorizing Interlocal Agreement between the

City and **DEPARTMENT OF STATE HEALTH SERVICES** for Analytical Laboratory Testing Services for the Public Works and Engineering Department (DSHS Contract No. 2017-049754-001); providing a maximum contract amount - \$152,400.00 - Enterprise Fund

33. ORDINANCE approving payment of \$13,356.88 to **HOUSTON HARRIS DIVISION PATROL, INC** for Emergency Armed Security Guard Services for various Houston Health Departments and Solid Waste Management Departments - General Fund - **DISTRICTS B - DAVIS; C - COHEN; D - BOYKINS; H - CISNEROS; I - GALLEGOS and J - LASTER**
34. ORDINANCE approving and authorizing Professional Materials Engineering and Testing Services Laboratory Contracts between the City of Houston and (1) **AUSTIN-REED ENGINEERS, LLC**, (2) **KLEINFELDER, INC**, (3) **RABAKISTNER, INC**, (4) **ALL-TERRA ENGINEERING, INC**, (5) **ASSOCIATED TESTING LABORATORIES, INC**, (6) **PROFESSIONAL SERVICES INDUSTRIES, INC**, (7) **GEOTECH ENGINEERING AND TESTING, INC**, (8) **ECS TEXAS, LLP**, (9) **ALPHA TESTING, INC**, (10) **QC LABORATORIES, INC**, (11) **GORRONDONA ENGINEERING SERVICES, INC**, (12) **KENALL, INC**, (13) **GEOTEST ENGINEERING, INC**, respectively
35. ORDINANCE consenting to the addition of 9.98 acres of land to **HARRIS COUNTY MUNICIPAL UTILITY DISTRICT NO. 64**, for inclusion in its district
36. ORDINANCE consenting to the addition of 45.3788 acres of land to **HARRIS COUNTY MUNICIPAL UTILITY DISTRICT NO. 148**, for inclusion in its district
37. ORDINANCE consenting to the creation of **HARRIS COUNTY MUNICIPAL UTILITY DISTRICT NO. 538**
38. ORDINANCE consenting to the addition of 4.4822 acres of land to **MONTGOMERY COUNTY WATER CONTROL AND IMPROVEMENT DISTRICT NO. 1**, for inclusion in its district
39. ORDINANCE consenting to the addition of 3.837 acres of land to **REID ROAD MUNICIPAL UTILITY DISTRICT NO. 1**, for inclusion in its district
40. ORDINANCE appropriating \$3,000,000.00 out of Water & Sewer System Consolidated Construction Fund and \$1,018,000.00 out of Street & Traffic Control & Storm Drainage DDSRF for Fiscal Year 2017 Funding for Developer Participation Contracts (Approved by Ordinance No. 2008-0307, as amended)
41. ORDINANCE awarding contracts to **MAIN LANE INDUSTRIES, LTD.** and **ISI CONTRACTING, INC** for Concrete Panel Replacement for City streets for the Department of Public Works & Engineering; setting a deadline for the bidder's execution of the contract and delivery of all bonds, insurance, and other required contract documents to the City; holding the bidder in default if it fails to meet the deadlines - Four-years with one option year to extend - \$32,992,042.60 - Dedicated Drainage & Street Renewal Fund
42. ORDINANCE appropriating \$1,395,253.50 out of Street & Traffic Control and Storm Drainage DDSRF Fund; awarding contract to **ISI CONTRACTING, INC** for On-Call Neighborhood Traffic Management Program Construction contract; setting a deadline for the bidder's execution of the contract and delivery of all bonds, insurance, and other required contract documents to the City; holding the bidder in default if it fails to meet the deadlines; providing funding for contingencies and engineering and testing services relating to construction of

facilities financed by the Street & Traffic Control and Storm Drainage DDSRF Fund

43. ORDINANCE appropriating \$1,938,410.00 out of Water & Sewer System Consolidated Construction Fund for installation of a Main Canal Radial Gate Bypass supplying raw water to the City of Houston under contract awarded by Coastal Water Authority to **BRH GARVER CONSTRUCTION, L.P.** pursuant to an operating contract with the Coastal Water Authority (as approved by Ordinance No. 1995-676)

END OF CONSENT AGENDA

CONSIDERATION OF MATTERS REMOVED FROM CONSENT AGENDA

NON CONSENT AGENDA - NUMBER 44

NON-CONSENT - MISCELLANEOUS

44. **SET A PUBLIC HEARING DATE** regarding a proposal to convey an easement in Keith-Wiess Park for Storm Sewer Outfall related to the Aldine Town Center Project - **DISTRICT B - DAVIS**
HEARING DATE - WEDNESDAY - 9:00 A.M. - NOVEMBER 30, 2016

MATTERS TO BE PRESENTED BY COUNCIL MEMBERS - Council Member Laster first

ALL ORDINANCES ARE TO BE CONSIDERED ON AN EMERGENCY BASIS AND TO BE PASSED ON ONE READING UNLESS OTHERWISE NOTED, ARTICLE VII, SECTION 7, CITY CHARTER

NOTE WHENEVER ANY AGENDA ITEM, WHETHER OR NOT ON THE CONSENT AGENDA, IS NOT READY FOR COUNCIL ACTION AT THE TIME IT IS REACHED ON THE AGENDA, THAT ITEM SHALL BE PLACED AT THE END OF THE AGENDA FOR ACTION BY COUNCIL WHEN ALL OTHER AGENDA ITEMS HAVE BEEN CONSIDERED.

CITY COUNCIL RESERVES THE RIGHT TO TAKE UP AGENDA ITEMS OUT OF THE ORDER IN WHICH THEY ARE POSITIONED IN THIS AGENDA. ALSO, AN ITEM THAT HAS BEEN TAGGED UNDER CITY COUNCIL RULE (HOUSTON CITY CODE 2-2) OR DELAYED TO ANOTHER DAY MAY BE NEVERTHELESS CONSIDERED LATER AT THE SAME CITY COUNCIL MEETING.



CITY OF HOUSTON - CITY COUNCIL

Meeting Date: 10/25/2016

Item Creation Date:

SP102516

Agenda Item#:

ATTACHMENTS:

Description

SP102516

Type

Signed Cover sheet

CITY COUNCIL CHAMBER - CITY HALL 2nd FLOOR – TUESDAY
October 25, 2016 – 2:00 PM

NON-AGENDA

2MIN 2MIN 2MIN

MS. MARY BLITZER – 3610 Fannin St. – 77004 – 281-940-6139 – Houston Bike Plan and Chapter 33

3MIN 3MIN 3MIN

MR. MATTHEW WHITESIDE – 950 Villa De Matel Rd. – 77023 – 305-282-8785 – Houston Bike Plan and Chapter 33

MS. LAURA JORDAN – 302 Empress Dr. – 77034 – 713-545-2699 – Edificitur Program

MS. DEBORAH BROOKS – 11078 Spottswood Dr. – 77016 – 832-785-0753 – Complaints/High water bill

DR. SHEILA OWENS-COLLINS – 15626 Gold Ring Way – Derwood, MD - 20855 – 618-303-9627 – Water bills at 4135 Gairloch Ln. – 77025

MS. DEBORAH ELAINE ALLEN – P. O. Box 263252 – 77027 – 713-264-0127 – Black Matters and Matters Work

MS. LYDIA GREENE – 6323 Anderson Rd. – 77085 – 832-577-8335 – Problems with neighborhood

MS. BRIDGET ALEXANDER MCDANIEL – 8114 St. Lo Rd. – 77033 – 713-987-3854 – Metro Police and Churches

MS. BERNADETTE LAWS – 9305 Talton St. – 77078 – 713-202-4591 – Standing water and street repairs

MS. SHARON VANCE – 8415 Cabot St. – 77078 – 832-964-4388 – Houston Police Department

MR. MARCUS GREEN – 1603 Rose Shadow Ln., #A – 77038 – 832-435-5841 – Helping people with felonies

PREVIOUS

1MIN 1MIN 1MIN

PRESIDENT JOSEPH CHARLES – P.O. Box 524373 - 77052 – 346-203-6873 – US-P/Charles-Shutdown-O/Entire City Government W/H-County W/FBI/TDPS



CITY OF HOUSTON - CITY COUNCIL

Meeting Date: 10/25/2016

District H

Item Creation Date: 8/29/2016

ARA-Nitsch & Son Water-Sewer Rate Hearing

Agenda Item#: 1.

Summary:

PUBLIC HEARING regarding just and reasonable rates to be observed within the City of Houston relating to the Retail Water and Sewer Rates of **NITSCH AND SON UTILITY COMPANY, INC - DISTRICT H - CISNEROS**

Background:

The Administration & Regulatory Affairs Department (ARA) recommends that City Council adopt an ordinance setting a public hearing related to the retail water and sewer rates of Nitsch & Son Utility Company, Inc. for October 5, 2016.

Nitsch is an investor owned water/wastewater utility (IOU) with exclusive authority to provide water and sewer services to customers within its certificated service areas as granted under Certificate of Convenience (CCN) No. 11124 (water) and No. 20446 (sewer). CCNs are issued by the Public Utility Commission of Texas (PUC) and are granted for an indefinite period of time. The City of Houston exercises original jurisdiction over Nitsch's rates under the provisions of the Texas Water Code for customers within city limits.

On June 20, 2016, Nitsch filed an application with the City of Houston to increase its water and sewer rates for customers located in Bellmar Terrace, Assumption Heights, Little York, Cortlandt Meadows and Lazy Meadows subdivisions (Council District H). According to the Company, Nitsch serves approximately 139 (water) and 53 (sewer) Houston customers. Based on the information in Company's Rate/Tariff Change Application, Nitsch seeks an approximate 42% increase (5/8 x 3/4" meter) and a 44% increase (1" meter) in existing water rates, and a 40% increase in sewer rates (all meters) based on 5,000 gallon usage. The specific rate impact to Houston customers will vary by service, meter size and gallons used.

On July 13, 2016, City Council approved Ordinance No. 2016-555 suspending the new rates for 90 days beyond the proposed effective date of July 25, 2016 to October 23, 2016. City Council approved the rate suspension to allow the City time to engage a rate expert to review the rate request, request information from the Company related to the proposed increase, and assist with the preparation of a final rate commendation. During this period, the City will also conduct a public meeting for in-City customers to allow ratepayers the opportunity to provide comment regarding quality of service and/or the proposed rate change.

During the public hearing, City Council will consider comments received by customers at the public

meeting, Nitsch's requested new rates, and any recommendations by the City for adjustments to Nitsch's rates. The City's rate expert will present a summary of findings and rate recommendation during the hearing. Nitsch and any Intervenors will also have the opportunity to present their respective positions. A proposed rate ordinance incorporating the findings and recommendations will be presented to City Council for approval on October 12, 2016. Pursuant to State Law, City Council must make a final determination regarding the rate request no later than October 23, 2016.

Departmental Approval Authority:

Tina Paez, Director
Administration & Regulatory
Affairs Department

Other Authorization

Prior Council Action:

July 13, 2016: Ordinance No. 2016-555

Contact Information:

Lara Cottingham Phone:(832) 393-8503

Alisa Talley Phone:(832) 393-8531

ATTACHMENTS:

Description

8.30.2016 Nitsch & Son Rate Hearing RCA

Type

Signed Cover sheet



CITY OF HOUSTON - CITY COUNCIL

Meeting Date: 9/13/2016

District H

Item Creation Date: 8/29/2016

ARA-Nitsch & Son Water-Sewer Rate Hearing

Background:

The Administration & Regulatory Affairs Department (ARA) recommends that City Council adopt an ordinance setting a public hearing related to the retail water and sewer rates of Nitsch & Son Utility Company, Inc. for October 5, 2016.

Nitsch is an investor owned water/wastewater utility (IOU) with exclusive authority to provide water and sewer services to customers within its certificated service areas as granted under Certificate of Convenience (CCN) No. 11124 (water) and No. 20446 (sewer). CCNs are issued by the Public Utility Commission of Texas (PUC) and are granted for an indefinite period of time. The City of Houston exercises original jurisdiction over Nitsch's rates under the provisions of the Texas Water Code for customers within city limits.

On June 20, 2016, Nitsch filed an application with the City of Houston to increase its water and sewer rates for customers located in Bellmar Terrace, Assumption Heights, Little York, Cortlandt Meadows and Lazy Meadows subdivisions (Council District H). According to the Company, Nitsch serves approximately 139 (water) and 53 (sewer) Houston customers. Based on the information in Company's Rate/Tariff Change Application, Nitsch seeks an approximate 42% increase (5/8 x 3/4" meter) and a 44% increase (1" meter) in existing water rates, and a 40% increase in sewer rates (all meters) based on 5,000 gallon usage. The specific rate impact to Houston customers will vary by service, meter size and gallons used.

On July 13, 2016, City Council approved Ordinance No. 2016-555 suspending the new rates for 90 days beyond the proposed effective date of July 25, 2016 to October 23, 2016. City Council approved the rate suspension to allow the City time to engage a rate expert to review the rate request, request information from the Company related to the proposed increase, and assist with the preparation of a final rate commendation. During this period, the City will also conduct a public meeting for in-City customers to allow ratepayers the opportunity to provide comment regarding quality of service and/or the proposed rate change.

During the public hearing, City Council will consider comments received by customers at the public meeting, Nitsch's requested new rates, and any recommendations by the City for adjustments to Nitsch's rates. The City's rate expert will present a summary of findings and rate recommendation during the hearing. Nitsch and any Intervenors will also have the opportunity to present their respective positions. A proposed rate ordinance incorporating the findings and recommendations will be presented to City Council for approval on October 12, 2016. Pursuant to State Law, City Council must make a final determination regarding the rate request no later than October 23, 2016.

Departmental Approval Authority:

**Tina Paez, Director
Administration & Regulatory
Affairs Department**

Other Authorization

Contact Information:

Lara Cottingham Phone: (832) 393-8503

Alisa Tally Phone: (832) 393-8643



CITY OF HOUSTON - CITY COUNCIL

Meeting Date: 10/25/2016

Item Creation Date: 10/4/2016

MYR ~ 2016 TIRZ # 9 and South Post Oak RA ReAppts. ltr.
10-4-16

Agenda Item#: 2.

Summary:

REQUEST from Mayor for confirmation of the appointment or reappointment of the following individuals to **REINVESTMENT ZONE NUMBER NINE, CITY OF HOUSTON, TEXAS (SOUTH POST OAK ZONE) BOARD OF DIRECTORS:**

Position Three - **ALGENITA SCOTT DAVIS**, reappointment, for a term to expire 12/31/2017, and to serve as Chair for a term ending 12/31/2016

Position Four - **PAUL E. JEFFERSON**, appointment, for a term to expire 2/31/2017

Position Five - **TANDELYN ATKINSON WEAVER**, reappointment, for a term to expire 12/31/2017

Background:

September 23, 2016

The Honorable City Council
City of Houston, Texas

Dear Council Members:

Pursuant to Texas Tax Code Section 311.009(b) and City of Houston, Texas Ordinance No. 97-1570, I am nominating the following individuals for appointment or reappointment to the Reinvestment Zone Number Nine, City of Houston, Texas (South Post Oak Zone) Board of Directors:

Algenita Scott Davis, reappointment to Position Three, for a term to expire December 31, 2017, and to server as Chair for a term ending December 31, 2016;

Paul E. Jefferson, appointment to Position Four, for a term to expire December 31, 2017;
and

Tandelyn Atkinson Weaver, reappointment to Position Five, for a term to expire December 31, 2017.

Pursuant to the bylaws of the South Post Oak Redevelopment Authority, appointment of a director to the board of this Zone will also constitute appointment of the director to the corresponding position on the Board of Directors of the Authority for the same term.

The résumés of the nominees are attached for your review

Sincerely,

ATTACHMENTS:

Description

Type



CITY OF HOUSTON - CITY COUNCIL

Meeting Date: 10/25/2016

ALL

Item Creation Date: 9/26/2016

HAS - Extend Unpaid Leave for M. Gonzalez

Agenda Item#: 3.

Summary:

RECOMMENDATION from Director of Aviation to extend unpaid leave of absence for **MARTHA GONZALEZ**, Semi-Skilled Laborer

Background:

Approve the motion to extend unpaid leave of absence for **Martha Gonzalez, Semi-Skilled Laborer**.

Specific Explanation:

The Aviation Department requests Council to approve a motion to extend the unpaid leave of absence of Martha Gonzalez, Semi-Skilled Laborer, Employee #125092, beginning June 19, 2016 through August 29, 2016.

Ms. Gonzalez has a medical condition which prevented her return to duty since October 02, 2015. Ms. Gonzalez provided the department with a resume so that a job search could be conducted, but it was unsuccessful. On August 16, 2016, the department recommended that Ms. Gonzalez be medically separated. On August 30, 2016 the Civil Service Commission ruled in favor of the department and Ms. Gonzalez's medical separation was effective August 30, 2016.

Ms. Gonzalez was approved for the Municipal Employee's Civil Service Commission for unpaid leave of absence through June 18, 2016. In accordance with Code of Ordinances 14-172, any further leaves of absences must be approved by the City Council. Therefore, the department requests City Council approve the extended unpaid leave of absence for Ms. Gonzalez from June 19, 2016 through August 29, 2016.

Director's Signature:

Mario C. Diaz
Houston Airport System

Contact Information:

Rhonda Arnold 2/233-1618
Harleen Smith 2/233-1775

ATTACHMENTS:

Description	Type
-------------	------

HAS Signed RCA

Signed Cover sheet



CITY OF HOUSTON - CITY COUNCIL

Meeting Date: 10/11/2016

ALL

Item Creation Date: 9/28/2016

HAS - Extend Unpaid Leave for M. Gorzalez

Agenda Item#: 10.

Summary:

RECOMMENDATION from the Director of the Department of Aviation for extension of Unpaid Leave of Absence of MARTHA GONZALEZ, SEMI-SKILLED LABORER, from June 19, 2016 through August 29, 2016.

Background:

Approve the motion to extend unpaid leave of absence for Martha Gorzalez, Semi-Skilled Laborer.

Specific Explanation:

The Aviation Department requests Council to approve a motion to extend the unpaid leave of absence of Martha Gorzalez, Semi-Skilled Laborer, Employee #125092, beginning June 19, 2016 through August 29, 2016.

Ms. Gorzalez has a medical condition which prevented her return to duty since October 02, 2015. Ms. Gorzalez provided the department with a resume so that a job search could be conducted, but it was unsuccessful. On August 16, 2016, the department recommended that Ms. Gorzalez be medically separated. On August 30, 2016 the Civil Service Commission ruled in favor of the department and Ms. Gorzalez's medical separation was effective August 30, 2016.

Ms. Gorzalez was approved for the Municipal Employee's Civil Service Commission for unpaid leave of absence through June 18, 2016. In accordance with Code of Ordinances 14-172, any further leaves of absences must be approved by the City Council. Therefore, the department requests City Council approve the extended unpaid leave of absence for Ms. Gorzalez from June 19, 2016 through August 29, 2016.

Director's Signature:



Mario C. Diaz
Houston Airport System

Contact Information:

Rhonda Arnold 2/233-1618
Harleen Smith 2/233-1775



CITY OF HOUSTON - CITY COUNCIL

Meeting Date: 10/25/2016

ALL

Item Creation Date: 9/26/2016

HAS - Extend Unpaid Leave for G. Phipps

Agenda Item#: 4.

Summary:

RECOMMENDATION from Director of Aviation to extend unpaid leave of absence for **GREGG PHIPPS**, Operations Coordinator

Background:

Approve the motion to extend unpaid leave of absence for **Gregg Phipps, Airport Operations Coordinator**.

Specific Explanation:

The Aviation Department requests Council to approve a motion to extend the unpaid leave of absence of Gregg Phipps, Airport Operations Coordinator, Employee #126286, beginning August 29, 2016 through August 29, 2016.

Mr. Phipps has a medical condition which prevented his return to duty since December 03, 2015. Mr. Phipps provided the department with a resume so that a job search could be conducted, but it was unsuccessful. On August 16, 2016, the department recommended that Mr. Phipps be medically separated. On August 30, 2016 the Civil Service Commission ruled in favor of the department and Mr. Phipps' medical separation was effective August 30, 2016.

Mr. Phipps was approved for the Municipal Employee's Civil Service Commission for unpaid leave of absence through August 28, 2016. In accordance with Code of Ordinances 14-172, any further leaves of absences must be approved by the City Council. Therefore, the department requests City Council approve the extended unpaid leave of absence for Mr. Phipps from August 29, 2016 through August 29, 2016.

Director's Signature:

Mario C. Diaz
Houston Airport System

Contact Information:

Rhonda Arnold 2/233-1618
Harleen Smith 2/233-1775

ATTACHMENTS:

Description	Type
-------------	------

HAS Signed RCA

Signed Cover sheet



CITY OF HOUSTON - CITY COUNCIL

Meeting Date: 10/11/2016

ALL

Item Creation Date: 9/28/2016

HAS - Extend Unpaid Leave for G. Phipps

Agenda Item#: 9.

Summary:

RECOMMENDATION from the Director of the Department of Aviation for extension of Unpaid Leave of Absence of GREGG PHIPPS, AIRPORT OPERATIONS COORDINATOR, from August 29, 2016 through August 29, 2016.

Background:

Approve the motion to extend unpaid leave of absence for Gregg Phipps, Airport Operations Coordinator.

Specific Explanation:

The Aviation Department requests Council to approve a motion to extend the unpaid leave of absence of Gregg Phipps, Airport Operations Coordinator, Employee #126286, beginning August 29, 2016 through August 29, 2016.

Mr. Phipps has a medical condition which prevented his return to duty since December 03, 2015. Mr. Phipps provided the department with a resume so that a job search could be conducted, but it was unsuccessful. On August 16, 2016, the department recommended that Mr. Phipps be medically separated. On August 30, 2016 the Civil Service Commission ruled in favor of the department and Mr. Phipps' medical separation was effective August 30, 2016.

Mr. Phipps was approved for the Municipal Employee's Civil Service Commission for unpaid leave of absence through August 28, 2016. In accordance with Code of Ordinances 14-172, any further leaves of absences must be approved by the City Council. Therefore, the department requests City Council approve the extended unpaid leave of absence for Mr. Phipps from August 29, 2016 through August 29, 2016.

Director's Signature:

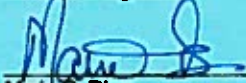
Mario C. Diaz
Houston Airport System

Contact Information:

Rhonda Arnold 2/233-1618
Harleen Smith 2/233-1775



CITY OF HOUSTON - CITY COUNCIL

Meeting Date: 10/25/2016

District B, District E, District F, District I

Item Creation Date: 10/13/2016

20PJ80 Accept Work/IIU-FEI

Agenda Item#: 5.

Summary:

RECOMMENDATION from Director Department of Public Works & Engineering for approval of final contract amount of \$665,703.95 and acceptance of work on contract with **IIU-FEI SAFE SIDEWALK JV** for Safe Sidewalk Program - 7.25% under the original contract amount - **DISTRICTS B - DAVIS; E - MARTIN; F - LE and I - GALLEGOS**

Background:

SUBJECT: Accept Work for Safe Sidewalk Program; WBS No. N-320610-0113-4.

RECOMMENDATION: (Summary) Pass a motion to approve the final Contract Amount of \$665,703.95 or 7.25% under the original Contract Amount, accept the Work and authorize final payment.

PROJECT NOTICE/JUSTIFICATION: This project was part of the continuing efforts by the City to construct request-based sidewalks throughout the City of Houston to meet the needs of its residents.

DESCRIPTION/SCOPE: The project provided for the construction of sidewalk improvements at various locations. Edminister, Hinshaw, Russ and Associates, Inc. designed the project with 149 calendar days allowed for construction. The project was awarded to IIU-FEI Safe Sidewalk JV with an original Contract Amount of \$717,769.10.

LOCATION: The project is located in various Key Map Grids.

Street	From	To	Council District
Lavender	Pardee Street	Hunting Bayou	B
Kingwood Drive	Green Oak Drive	Sorters Road	E
Dairyview Lane	Wellington Park Drive	Newbrook Drive	F
Dunvegan Way	Oates Road	Mercury Drive	I

CONTRACT COMPLETION AND COST: The Contractor, IIU-FEI Safe Sidewalk JV has completed the work under the subject Contract. The project was completed on time with additional 30 days approved by Change Order No. 1. The final cost of the project, including overrun and underrun of estimated unit price quantities and previously approved Change Order No. 1 is \$665,703.95, a decrease of \$52,065.05 or 7.25% under the original Contract Amount.

The decreased cost is a result of the difference between planned and measured quantities. This decrease is primarily the result of an underrun in various Base Unit Price Items and Extra Unit Price Items, which was not necessary to complete the project.

MWSBE PARTICIPATION: No City MWSBE participation goal is established for this project as the contract does not exceed the threshold of \$1,000,000.00 required for a goal oriented contract per Section 15-82 of the Code of Ordinances

Prior Council Action:

Ordinance 2014-0568, dated 06/14/2014

Amount of Funding:

No additional funding required.

Total (original) appropriation of \$834,000 from METRO Construction – Other - Fund No. 4040A.

Contact Information:

Joseph T. Myers, P.E.
Senior Assistant Director
Phone: (832) 395-2355

ATTACHMENTS:

Description

Signed RCA
Maps

Type

Signed Cover sheet
Backup Material

TO: Mayor via City Secretary

REQUEST FOR COUNCIL ACTION

SUBJECT: Accept Work for Safe Sidewalk Program;
WBS No. N-320610-0113-4.

Page
1 of 1

Agenda Item
#

FROM (Department or other point of origin):

Origination Date

Agenda Date

Department of Public Works and Engineering

DIRECTOR'S SIGNATURE:

Council District affected:

B, E, F, I *BK*

Dale A. Rudick, P.E., Director

For additional information contact:

Date and identification of prior authorizing
Council action:

Joseph T. Myers 10/5/16

Joseph T. Myers, P.E.
Senior Assistant Director

Ordinance # 2014-0568 dated: 06/04/2014

Phone: (832) 395-2355

RECOMMENDATION: (Summary) Pass a motion to approve the final Contract Amount of \$665,703.95 or 7.25% under the original Contract Amount, accept the Work and authorize final payment.

Amount and Source of Funding: No additional funding required.

Total (original) appropriation of \$834,000 from METRO Construction – Other - Fund No. 4040A.

PROJECT NOTICE/JUSTIFICATION: This project was part of the continuing efforts by the City to construct request-based sidewalks throughout the City of Houston to meet the needs of its residents.

DESCRIPTION/SCOPE: The project provided for the construction of sidewalk improvements at various locations. Edminister, Hinshaw, Russ and Associates, Inc. designed the project with 149 calendar days allowed for construction. The project was awarded to IIU-FEI Safe Sidewalk JV with an original Contract Amount of \$717,769.10.

LOCATION: The project is located in various Key Map Grids.

Street	From	To	Council District
Lavender	Pardee Street	Hunting Bayou	B
Kingwood Drive	Green Oak Drive	Sorters Road	E
Dairyview Lane	Wellington Park Drive	Newbrook Drive	F
Dunvegan Way	Oates Road	Mercury Drive	I

CONTRACT COMPLETION AND COST: The Contractor, IIU-FEI Safe Sidewalk JV has completed the work under the subject Contract. The project was completed on time with additional 30 days approved by Change Order No. 1. The final cost of the project, including overrun and underrun of estimated unit price quantities and previously approved Change Order No. 1 is \$665,703.95, a decrease of \$52,065.05 or 7.25% under the original Contract Amount.

The decreased cost is a result of the difference between planned and measured quantities. This decrease is primarily the result of an underrun in various Base Unit Price Items and Extra Unit Price Items, which was not necessary to complete the project.

REQUIRED AUTHORIZATION

CUID#

20PJ80

Finance Department:

Other Authorization:

Other Authorization:

Carol Ellinger Haddock, P.E.,
Deputy Director
Engineering and Construction Division

Date	SUBJECT: Accept Work for Safe Sidewalk Program; WBS No. N-320610-0113-4.	Originator's Initials B ✓	Page 2 of 2
-------------	--	---	-----------------------

M/WSBE PARTICIPATION: No City M/WSBE participation goal is established for this project as the contract does not exceed the threshold of \$1,000,000.00 required for a goal oriented contract per Section 15-82 of the Code of Ordinances.

all in RA BK
DAR:CEH:JTM:RA:BK:pa

H:\E&C Construction\ESC\PROJECTS\N-320610-0113-4 Safe Sidewalk Program\Close Out\RCA\20PJ80.doc

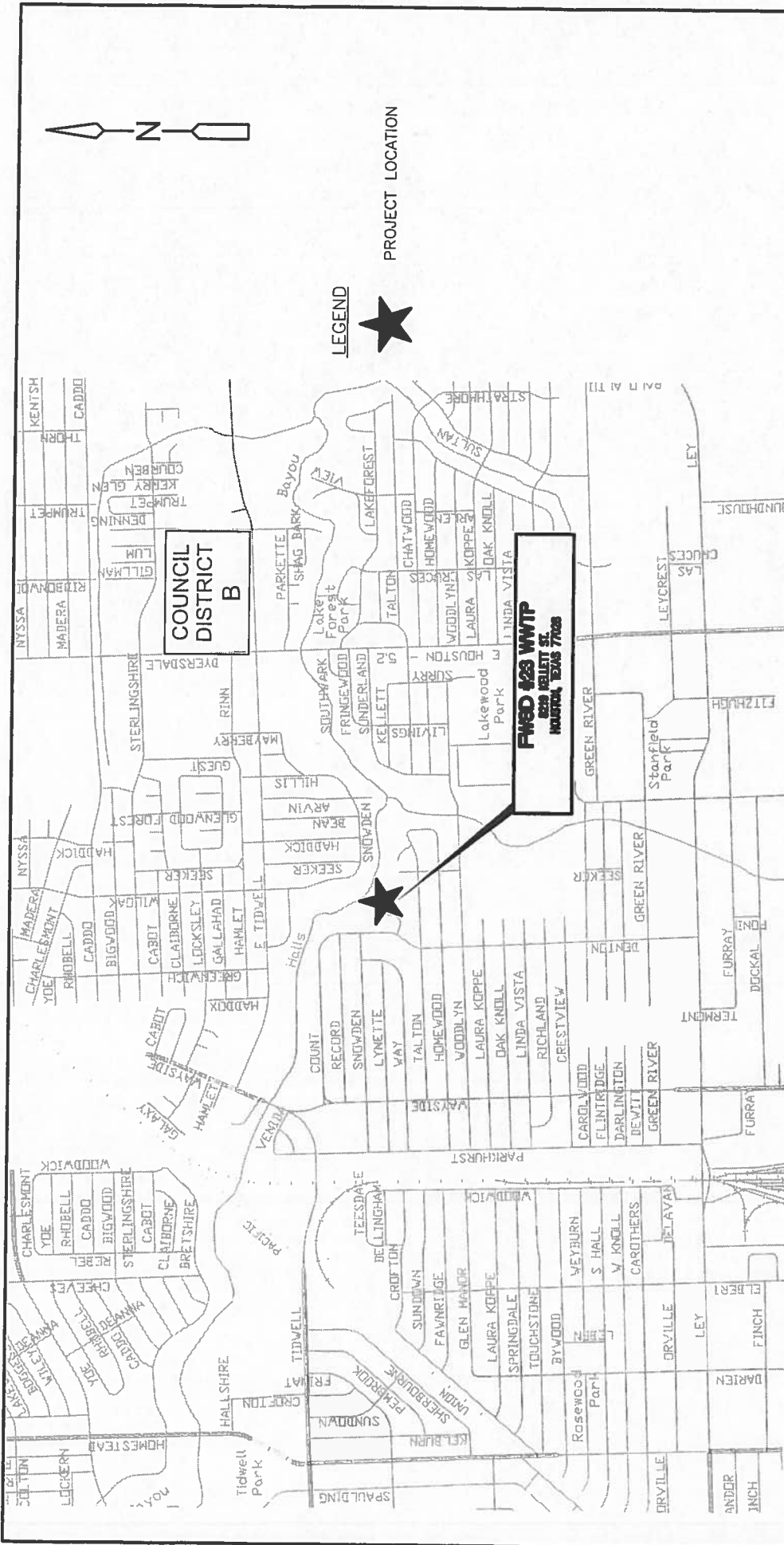

HARRIS COUNTY KEY MAP No 455F
 GIMS MAP NO 5661C
 VICINITY MAP
 NOT TO SCALE

CITY OF HOUSTON
 DEPARTMENT OF PUBLIC WORKS AND ENGINEERING
 ENGINEERING AND CONSTRUCTION DIVISION



3050 Post Oak Boulevard, Suite 300
 Houston, TX 77056
 Tel: (713) 423-7300
 TBPE Firm Registration No. F-3043

**CDM
 Smith**

FWSD #23
 WASTEWATER TREATMENT PLANT
 IMPROVEMENTS
 WBS No.: R-000265-0067-4

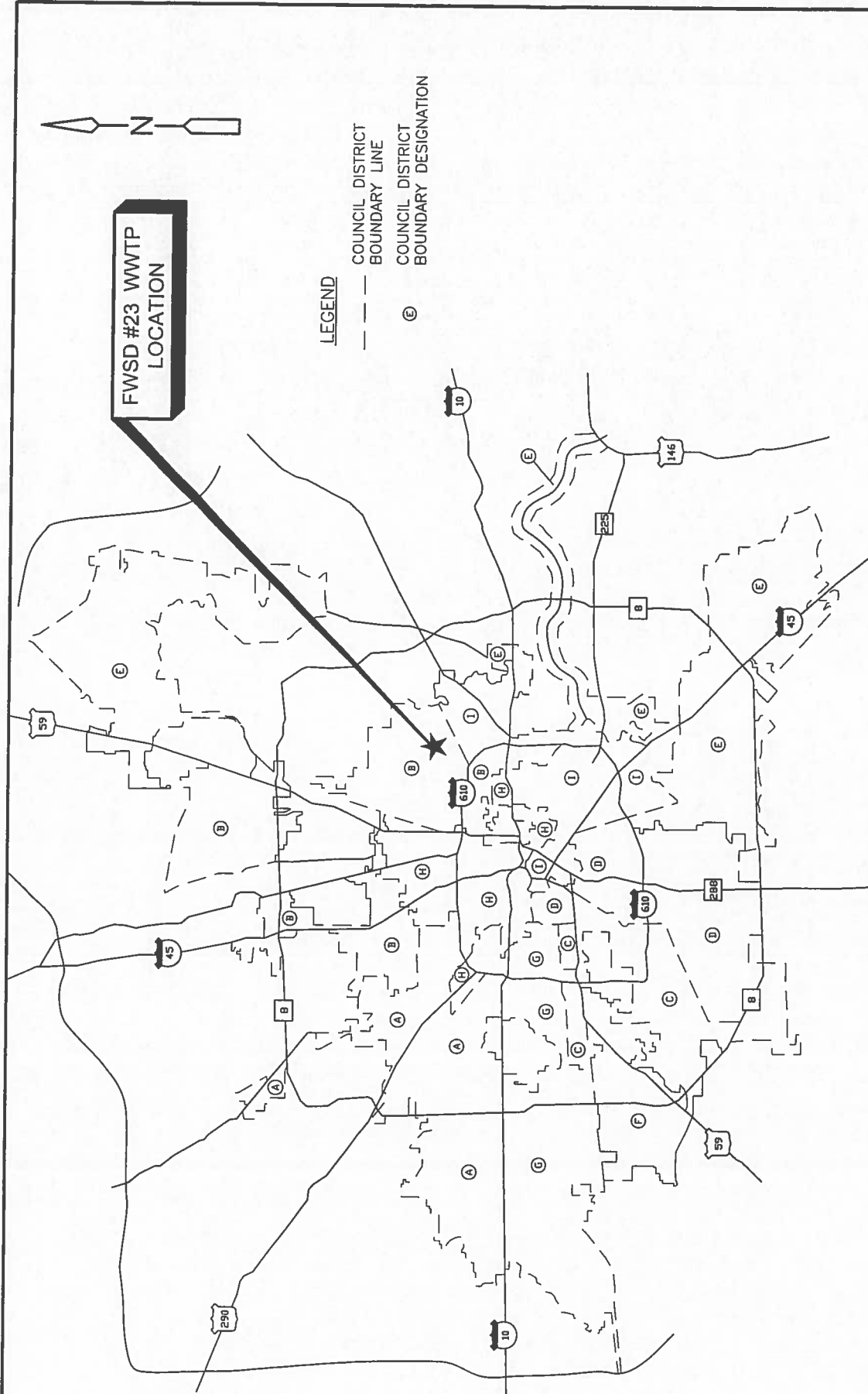

LOCATION MAP
NOT TO SCALE

CITY OF HOUSTON
DEPARTMENT OF PUBLIC WORKS AND ENGINEERING
ENGINEERING AND CONSTRUCTION DIVISION

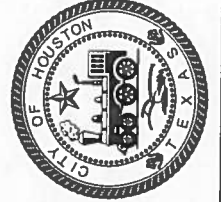

3050 Post Oak Boulevard, Suite 300
Houston, TX 77056
Tel: (713) 423-7300
TBPE Firm Registration No. F-3043

**CDM
Smith**

FWSD #23
WASTEWATER TREATMENT PLANT
IMPROVEMENTS
WBS No.: R-000265-0067-4



CITY OF HOUSTON - CITY COUNCIL

Meeting Date: 10/25/2016

District B

Item Creation Date: 10/13/2016

20PJ87 Accept Work/CSA Construction

Agenda Item#: 6.

Summary:

RECOMMENDATION from Director Department of Public Works & Engineering for approval of final contract amount of \$8,369,060.27 and acceptance of work on contract with **CSA CONSTRUCTION, INC** for FWSD No. 23 Wastewater Treatment Plant Improvements - 7.00% under the original contract amount - **DISTRICT B - DAVIS**

Background:

SUBJECT: Accept Work for FWSD No. 23 Wastewater Treatment Plant Improvements; WBS No. R-000265-0067-4.

RECOMMENDATION: (Summary) Pass a motion to approve the final Contract Amount of \$8,369,060.27 or 7.00% under the original Contract Amount, accept the Work and authorize final payment.

PROJECT NOTICE/JUSTIFICATION: This project was part of the City ongoing program to renew and replace inefficient components of existing wastewater treatment plants.

DESCRIPTION/SCOPE: The project consisted of development of the specific components of the FWSD No. 23 Wastewater Treatment Plant as follows: Construction of a new influent submersible lift station with six (6) new pumps, construction of a new electrical building and motor control center (MCC), demolition of two existing lift stations, removal and replacement of existing electrical actuators storm water gate with hydraulic actuators to provide fail close functionality in event of power outage. CDM Smith Inc. designed the project with 750 calendar days allowed for construction. The project was awarded to CSA Construction, Inc. with an original Contract Amount of \$8,999,200.00.

LOCATION: The project area is located at 8219 Kellett, Key Map No. 455G.

CONTRACT COMPLETION AND COST: The Contractor, CSA Construction, Inc. has completed the work under the subject Contract. The project was completed on time with additional 190 days approved by Change Order Nos. 1 and 2. The final cost of the project, including overrun and underrun of estimated unit price quantities and previously approved Change Order Nos. 1-4 is \$8,369,060.27, a decrease of \$630,139.73 or 7.00% under the original Contract Amount.

The decreased cost is a result of the difference between planned and measured quantities. This

decrease is primarily the result of an underrun in various Base Unit Price Items and Extra Unit Price Items, which was not necessary to complete the project.

M/WBE PARTICIPATION: The M/WBE goal established for this project was 18%. According to Office of Business Opportunity, the participation was 18.25%. Contractor's M/WBE/SBE performance evaluation was rated Satisfactory.

Prior Council Action:

Ordinance 2013-0271, dated 03/27/2013

Amount of Funding:

No additional funding required.

Total (original) appropriation of \$10,189,100.00 from the Water and Sewer System Consolidated Construction Fund No. 8500.

Contact Information:

Joseph T. Myers, P.E.
Senior Assistant Director
Phone: (832) 395-2355

ATTACHMENTS:

Description



Signed RCA
Maps

Type

Signed Cover sheet
Backup Material

TO: Mayor via City Secretary

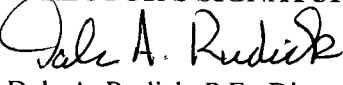
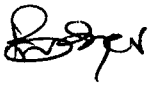
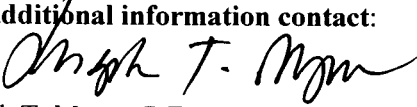
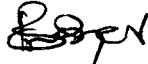
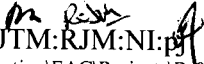
REQUEST FOR COUNCIL ACTION

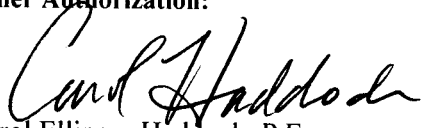
SUBJECT: Accept Work for FWSD No. 23 Wastewater Treatment Plant Improvements; WBS No. R-000265-0067-4.		Page 1 of 1	Agenda Item #
FROM (Department or other point of origin): Department of Public Works and Engineering		Origination Date	Agenda Date
DIRECTOR'S SIGNATURE:  Dale A. Rudick, P.E., Director		Council District affected: B 	
For additional information contact:  9/27/16 Joseph T. Myers, P.E. Senior Assistant Director Phone: (832) 395-2355		Date and identification of prior authorizing Council action:  Ordinance # 2013-0271 dated: 03/27/2013	
RECOMMENDATION: (Summary) Pass a motion to approve the final Contract Amount of \$8,369,060.27 or 7.00% under the original Contract Amount, accept the Work and authorize final payment.			
Amount and Source of Funding: No additional funding required. Total (original) appropriation of \$10,189,100.00 from the Water and Sewer System Consolidated Construction Fund No. 8500.			
PROJECT NOTICE/JUSTIFICATION: This project was part of the City ongoing program to renew and replace inefficient components of existing wastewater treatment plants.			
DESCRIPTION/SCOPE: The project consisted of development of the specific components of the FWSD No. 23 Wastewater Treatment Plant as follows: Construction of a new influent submersible lift station with six (6) new pumps, construction of a new electrical building and motor control center (MCC), demolition of two existing lift stations, removal and replacement of existing electrical actuators storm water gate with hydraulic actuators to provide fail close functionality in event of power outage. CDM Smith Inc. designed the project with 750 calendar days allowed for construction. The project was awarded to CSA Construction, Inc. with an original Contract Amount of \$8,999,200.00.			
LOCATION: The project area is located at 8219 Kellett, Key Map No. 455G.			
CONTRACT COMPLETION AND COST: The Contractor, CSA Construction, Inc. has completed the work under the subject Contract. The project was completed on time with additional 190 days approved by Change Order Nos. 1 and 2. The final cost of the project, including overrun and underrun of estimated unit price quantities and previously approved Change Order Nos. 1-4 is \$8,369,060.27, a decrease of \$630,139.73 or 7.00% under the original Contract Amount. The decreased cost is a result of the difference between planned and measured quantities. This decrease is primarily the result of an underrun in various Base Unit Price Items and Extra Unit Price Items, which was not necessary to complete the project.			
M/WBE PARTICIPATION: The M/WBE goal established for this project was 18%. According to Office of Business Opportunity, the participation was 18.25%. Contractor's MWBE/SBE performance evaluation was rated Satisfactory.			
DAR:CEH:  JTM:RJM:NI:  H:\E&C Construction\FAC\Projects\R-000265-0067-4 FWSD#23 WWTP Improvements\RCA\20PJ87.doc			
REQUIRED AUTHORIZATION		CUID#	20PJ87
Finance Department:	Other Authorization:	Other Authorization:  Carol Ellinger Haddock, P.E., Deputy Director Engineering and Construction Division	

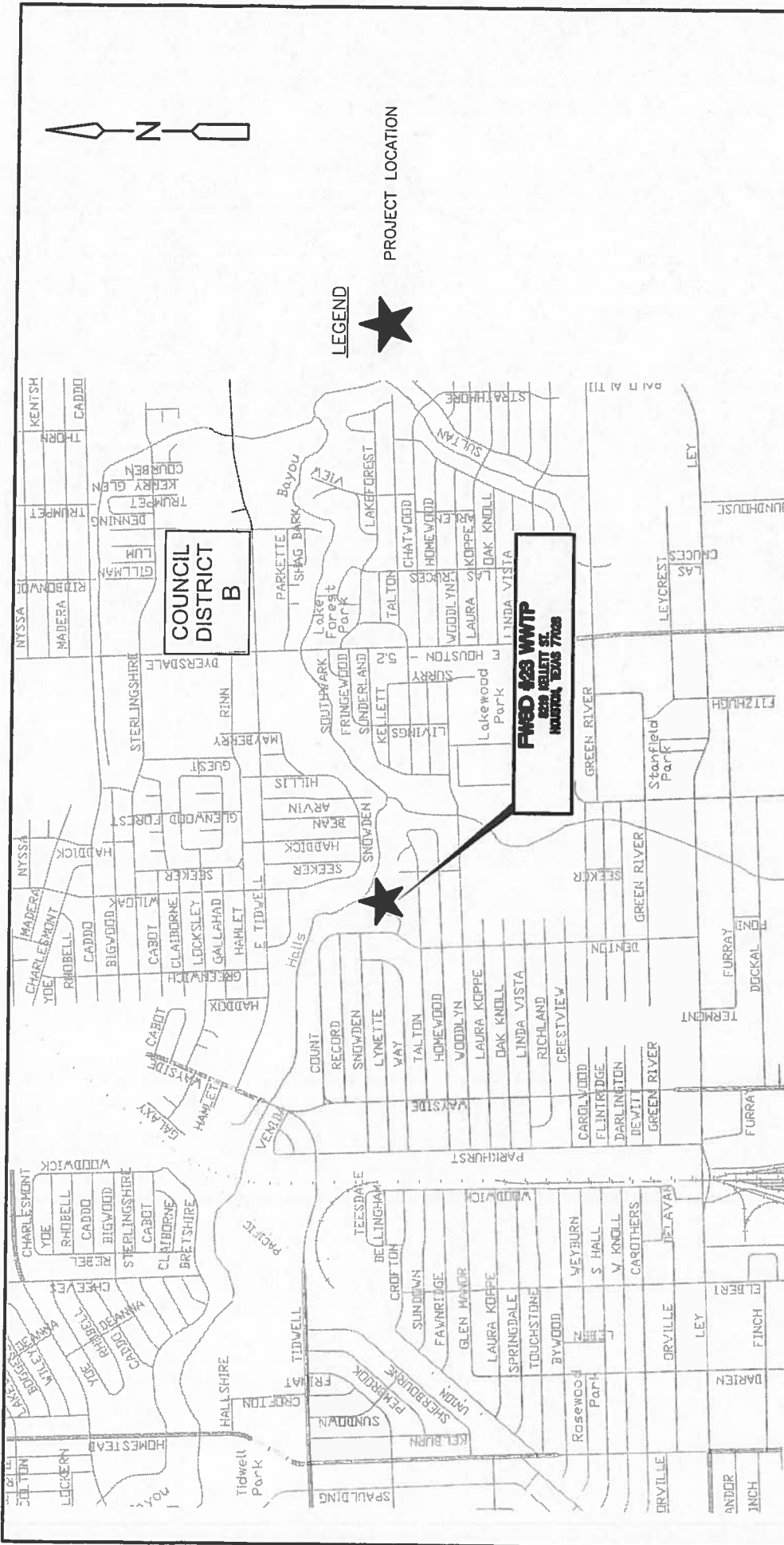

HARRIS COUNTY KEY MAP No 455F
 GIMS MAP NO 5661C
 VICINITY MAP
 NOT TO SCALE

CITY OF HOUSTON
 DEPARTMENT OF PUBLIC WORKS AND ENGINEERING
 ENGINEERING AND CONSTRUCTION DIVISION
 FWSD #23
 WASTEWATER TREATMENT PLANT
 IMPROVEMENTS
 WBS No.: R-000265-0067-4



3050 Post Oak Boulevard, Suite 300
 Houston, TX 77056
 Tel: (713) 423-7300
 TBPE Firm Registration No. F-3043



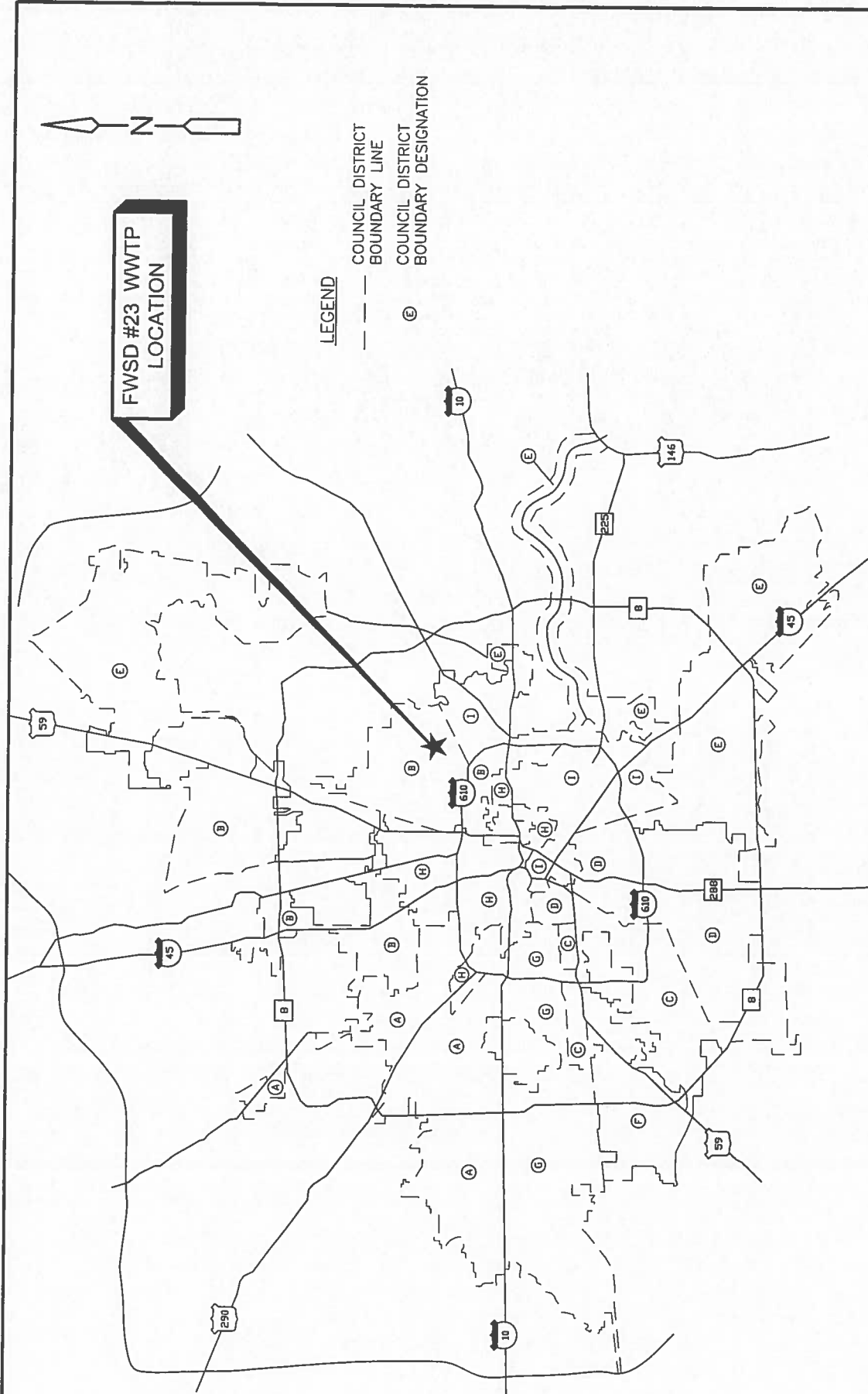

LOCATION MAP
NOT TO SCALE

CITY OF HOUSTON
DEPARTMENT OF PUBLIC WORKS AND ENGINEERING
ENGINEERING AND CONSTRUCTION DIVISION

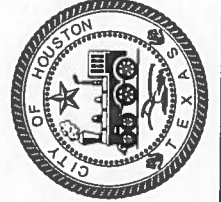

3050 Post Oak Boulevard, Suite 300
Houston, TX 77056
Tel: (713) 423-7300
TBPE Firm Registration No. F-3043

**CDM
Smith**

FWSD #23
WASTEWATER TREATMENT PLANT
IMPROVEMENTS
WBS No.: R-000265-0067-4



CITY OF HOUSTON - CITY COUNCIL

Meeting Date: 10/25/2016

District A

Item Creation Date: 10/12/2016

20PJ75 Accept Work/CF McDonald Electric

Agenda Item#: 7.

Summary:

RECOMMENDATION from Director Department of Public Works & Engineering for approval of final contract amount of \$843,879.03 and acceptance of work on contract with **C. F. MCDONALD ELECTRIC, INC** for Generator Relocation from Southwest Wastewater Treatment Plant to Northwest Wastewater Treatment Plant - 1.13% over the original contract amount and under 5% contingency amount - **DISTRICT A - STARDIG**

Background:

SUBJECT: Accept Work for Generator Relocation from Southwest Wastewater Treatment Plant to Northwest Wastewater Treatment Plant; WBS No. R-000265-0085-4.

RECOMMENDATION: (Summary) Pass a motion to approve the final Contract Amount of \$843,879.03 or 1.13% over the original Contract Amount and under 5% contingency amount, accept the Work and authorize final payment.

PROJECT NOTICE/JUSTIFICATION: This project was part of the City's ongoing program to make improvements to its wastewater treatment plants.

DESCRIPTION/SCOPE: The project consisted of relocation, reconditioning, refurbishing, testing, and complete installation of Waukesha VHP5900GSi gas engine generator system from Southwest Wastewater Treatment Plant (WWTP) to Northwest Wastewater Treatment Plant (WWTP). Chiang, Patel & Yerby, Inc. designed the project with 180 calendar days. The project was awarded to C. F. McDonald Electric, Inc. with an original Contract Amount of \$834,469.00.

LOCATION: The project area is located at 5423 Mangum, Houston Texas, Key Map Grid 451C.

CONTRACT COMPLETION AND COST: The Contractor, C.F. McDonald Electric, Inc. has completed the work under the subject Contract. The project was completed on time with additional 888 days approved by Change Order Nos. 1 and 2. The final cost of the project, including overrun and underrun of estimated unit price quantities and previously approved Change Order No. 1 is \$843,879.03, an increase of \$9,410.03 or 1.13% over the original Contract Amount and under 5% contingency amount.

The increased cost is a result of the difference between planned and measured quantities. This increase is primarily the result of an overrun in various Base Unit Price Items and Extra Unit Price

Items, which was necessary to complete the project.

MWBE/SBE PARTICIPATION: No City MWSBE participation goal was established for this project, as the contract will not be a goal oriented contract per Section 15-82 of the Code of Ordinances.

Prior Council Action:

Ordinance 2013-0232, dated 03/20/2013

Amount of Funding:

No additional funding required.

Total (original) appropriation of \$939,700.00 from Water and Sewer System Consolidated Construction Fund No. 8500

Contact Information:

Joseph T. Myers, P.E.
Senior Assistant Director
Phone: (832) 395-2355

ATTACHMENTS:

Description



Signed RCA
Maps

Type

Signed Cover sheet
Backup Material

TO: Mayor via City Secretary

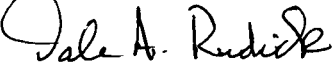
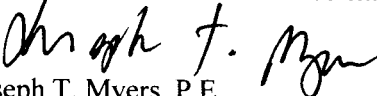
REQUEST FOR COUNCIL ACTION

SUBJECT: Accept Work for Generator Relocation from Southwest Wastewater Treatment Plant to Northwest Wastewater Treatment Plant; WBS No. R-000265-0085-4.		Page 1 of 1	Agenda Item #
FROM (Department or other point of origin): Department of Public Works and Engineering		Origination Date	Agenda Date
DIRECTOR'S SIGNATURE:  Dale A. Rudick, P.E., Director		Council District affected: A <i>MA</i>	
For additional information contact:  10/5/16 Joseph T. Myers, P.E. Senior Assistant Director Phone: (832) 395-2355		Date and identification of prior authorizing Council action: Ordinance # 2013-0232 dated: 03/20/2013	
RECOMMENDATION: (Summary) Pass a motion to approve the final Contract Amount of \$843,879.03 or 1.13% over the original Contract Amount and under 5% contingency amount, accept the Work and authorize final payment.			
Amount and Source of Funding: No additional funding required. Total (original) appropriation of \$939,700.00 from Water and Sewer System Consolidated Construction Fund No. 8500.			
PROJECT NOTICE/JUSTIFICATION: This project was part of the City's ongoing program to make improvements to its wastewater treatment plants.			
DESCRIPTION/SCOPE: The project consisted of relocation, reconditioning, refurbishing, testing, and complete installation of Waukesha VHP5900GSi gas engine generator system from Southwest Wastewater Treatment Plant (WWTP) to Northwest Wastewater Treatment Plant (WWTP). Chiang, Patel & Yerby, Inc. designed the project with 180 calendar days. The project was awarded to C. F. McDonald Electric, Inc. with an original Contract Amount of \$834,469.00.			
LOCATION: The project area is located at 5423 Mangum, Houston Texas, Key Map Grid 451C.			
CONTRACT COMPLETION AND COST: The Contractor, C.F. McDonald Electric, Inc. has completed the work under the subject Contract. The project was completed on time with additional 888 days approved by Change Order Nos. 1 and 2. The final cost of the project, including overrun and underrun of estimated unit price quantities and previously approved Change Order No. 1 is \$843,879.03, an increase of \$9,410.03 or 1.13% over the original Contract Amount and under 5% contingency amount. The increased cost is a result of the difference between planned and measured quantities. This increase is primarily the result of an overrun in various Base Unit Price Items and Extra Unit Price Items, which was necessary to complete the project.			
MWBE/SBE PARTICIPATION: No City MWSBE participation goal was established for this project, as the contract will not be a goal oriented contract per Section 15-82 of the Code of Ordinances.			
DAR:CEH:JTM:RJM:MA:  H:\E&C Construction\FAC\Projects\R-000265-0085-4 Generator Relocation from Northwest WWTP to Southwest WWTP\21.0 Close-Out Documentation\RCA\20PJ75.doc			
REQUIRED AUTHORIZATION 20PJ75			
Finance Department:	Other Authorization:	Other Authorization:  Carol Ellinger Haddock, P.E. Deputy Director Engineering and Construction Division	

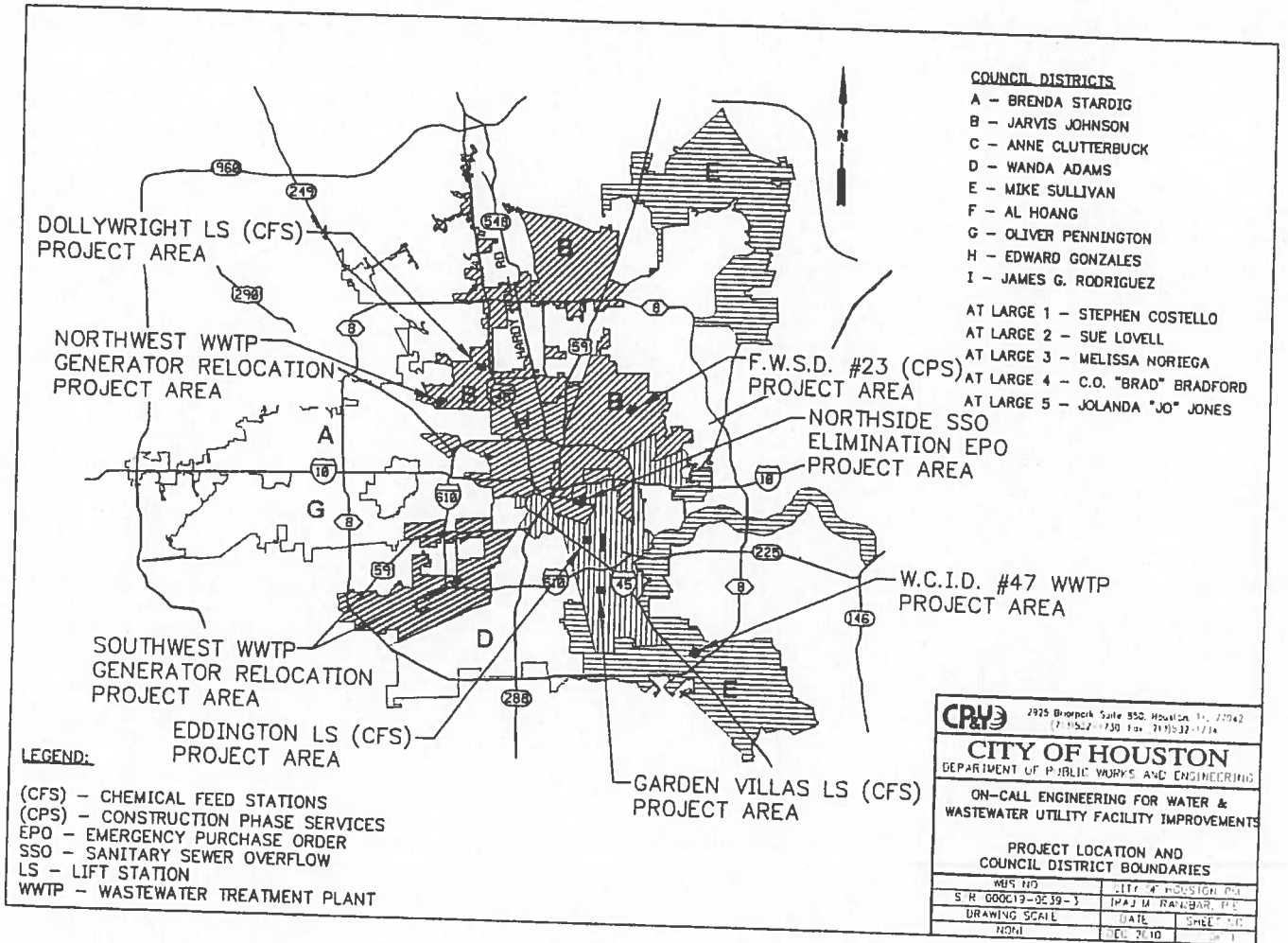

CRU 2925 Brookpark Suite 850, Houston, TX 77042
 (713) 527-7300 Fax (713) 527-1734

CITY OF HOUSTON
 DEPARTMENT OF PUBLIC WORKS AND ENGINEERING

ON-CALL ENGINEERING FOR WATER &
 WASTEWATER UTILITY FACILITY IMPROVEMENTS

PROJECT LOCATION AND
 COUNCIL DISTRICT BOUNDARIES

WPS NO	CITY OF HOUSTON P&E
S R 000019-0039-3	IPAJ M RALPH, P.E.
DRAWING SCALE	DATE SHEET NO
NONE	DEC 2010 SHEET 1

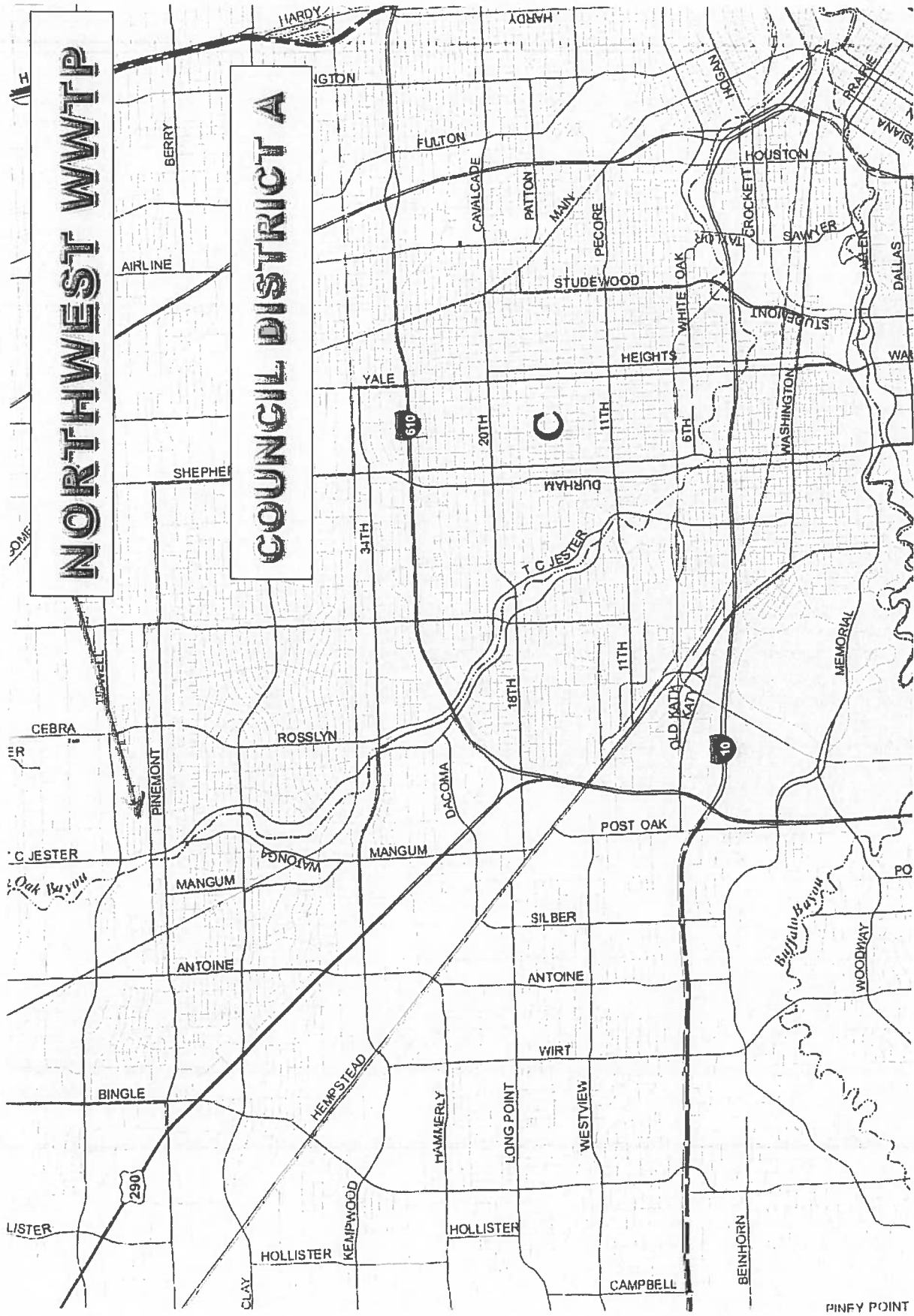

Generator Relocation from Southwest WWTP to Northwest WWTP

R-000265-0085-4



CITY OF HOUSTON - CITY COUNCIL

Meeting Date: 10/25/2016

District F

Item Creation Date: 10/12/2016

20PJ90 Accept Work/SJ Louis Construction

Agenda Item#: 8.

Summary:

RECOMMENDATION from Director Department of Public Works & Engineering for approval of final contract amount of \$4,246,345.47 and acceptance of work on contract with **S.J. LOUIS CONSTRUCTION OF TEXAS LTD.** for 42- inch Water Line along Bellaire Boulevard from Bellaire Braes Pump Station to South Kirkwood Road - 0.25% under the original contract amount - **DISTRICT F - LE**

Background:

SUBJECT: Accept Work for 42-inch Water Line along Bellaire Boulevard from Bellaire Braes Pump Station to South Kirkwood Road; WBS No. S-000900-0122-4.

RECOMMENDATION: (Summary) Pass a motion to approve the final Contract Amount of \$4,246,345.47 or 0.25% under the original Contract Amount, accept the Work and authorize final payment.

PROJECT NOTICE/JUSTIFICATION: This project was part of the City's Surface Water Transmission Program and is required to increase circulation and availability of water from the Bellaire Braes Pump Station.

DESCRIPTION/SCOPE: The project consisted of approximately 4,200 linear feet of 48/42/36-inch water line, valves and appurtenances, Bellaire Braes Pump Station plant site second access improvements, and Bellaire Boulevard esplanade landscaping. Lockwood, Andrews and Newnam designed the project with 270 calendar days allowed for construction. The project was awarded to S.J. Louis Construction of Texas Ltd. with an original Contract Amount of \$4,256,959.00.

LOCATION: The project area is generally located along Bellaire Boulevard bound by Bellaire Boulevard Right-of-Way on the north and south and is also bound by Kirkwood Road on the east and Dairy Ashford Road on the west. The project is located in Key Map Grids 528H and 529E.

CONTRACT COMPLETION AND COST: The Contractor, S.J. Louis Construction of Texas Ltd. has completed the work under the subject Contract. The project was completed beyond the established completion date. The City will make a deductive contract amount adjustment to the Contract Price of \$220,800.00 for 184 days at \$1,200 for liquidated damages based on the Mediation Agreement Proposal No.2 between the City and S.J. Louis Construction of Texas Ltd. The final cost of the project, including overrun and underrun of estimated unit price quantities and

previously approved Change Order Nos. 1 and 2 is \$4,246,345.47, a decrease of \$10,613.53 or 0.25% under the original Contract Amount.

The decreased cost is a result of the difference between planned and measured quantities. This decrease is primarily the result of an underrun in various Base Unit Price Items and Extra Unit Price Items, which was not necessary to complete the project.

M/WBE PARTICIPATION: The M/WBE goal established for this project was 18%. According to Office of Business Opportunity, the participation was 19.58%. Contractor's M/WBE performance evaluation was rated Satisfactory.

Prior Council Action:

Ordinance 2013-0495, dated 05/29/2013

Amount of Funding:

No additional funding required.

Total (original) appropriation of \$5,014,300.00 from Water and Sewer System Consolidated Construction Fund No. 8500.

Contact Information:

Joseph T. Myers, P.E.
Senior Assistant Director
Phone: (832) 395-2355

ATTACHMENTS:

Description

Signed RCA
Map

Type

Signed Cover sheet
Backup Material

TO: Mayor via City Secretary

REQUEST FOR COUNCIL ACTION

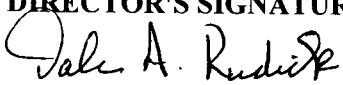
SUBJECT: Accept Work for 42-inch Water Line along Bellaire Boulevard from Bellaire Braes Pump Station to South Kirkwood Road; WBS No. S-000900-0122-4.	Page 1 of 1	Agenda Item #
FROM (Department or other point of origin): Department of Public Works and Engineering	Origination Date	Agenda Date
DIRECTOR'S SIGNATURE:  Dale A. Rudick, P.E., Director	Council District affected: F	
For additional information contact: Joseph T. Myers, P.E. Senior Assistant Director Phone: (832) 395-2355	Date and identification of prior authorizing Council action: Ordinance # 2013-0495 dated: 05/29/2013	

RECOMMENDATION: (Summary) Pass a motion to approve the final Contract Amount of \$4,246,345.47 or 0.25% under the original Contract Amount, accept the Work and authorize final payment.

Amount and Source of Funding: No additional funding required.
Total (original) appropriation of \$5,014,300.00 from Water and Sewer System Consolidated Construction Fund No. 8500.

PROJECT NOTICE/JUSTIFICATION: This project was part of the City's Surface Water Transmission Program and is required to increase circulation and availability of water from the Bellaire Braes Pump Station.

DESCRIPTION/SCOPE: The project consisted of approximately 4,200 linear feet of 48/42/36-inch water line, valves and appurtenances, Bellaire Braes Pump Station plant site second access improvements, and Bellaire Boulevard esplanade landscaping. Lockwood, Andrews and Newnam designed the project with 270 calendar days allowed for construction. The project was awarded to S.J. Louis Construction of Texas Ltd. with an original Contract Amount of \$4,256,959.00.

LOCATION: The project area is generally located along Bellaire Boulevard bound by Bellaire Boulevard Right-of-Way on the north and south and is also bound by Kirkwood Road on the east and Dairy Ashford Road on the west. The project is located in Key Map Grids 528H and 529E.

CONTRACT COMPLETION AND COST: The Contractor, S.J. Louis Construction of Texas Ltd. has completed the work under the subject Contract. The project was completed beyond the established completion date. The City will make a deductive contract amount adjustment to the Contract Price of \$220,800.00 for 184 days at \$1,200 for liquidated damages based on the Mediation Agreement Proposal No.2 between the City and S.J. Louis Construction of Texas Ltd. The final cost of the project, including overrun and underrun of estimated unit price quantities and previously approved Change Order Nos. 1 and 2 is \$4,246,345.47, a decrease of \$10,613.53 or 0.25% under the original Contract Amount.

The decreased cost is a result of the difference between planned and measured quantities. This decrease is primarily the result of an underrun in various Base Unit Price Items and Extra Unit Price Items, which was not necessary to complete the project.

M/WBE PARTICIPATION: The M/WBE goal established for this project was 18%. According to Office of Business Opportunity, the participation was 19.58%. Contractor's M/WBE performance evaluation was rated Satisfactory.

DAR:DRM:JTM:PK:MM:
H:\E&C Construction\NSC\PROJECT FOLDER\S-000900-0122-4 42inch water line along Bellaire Blvd\RCA\20PJ90(Mediatora).doc

REQUIRED AUTHORIZATION

CUIC ID# 20PJ90

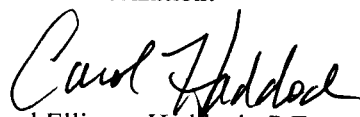
Finance Department:	Other Authorization:	Other Authorization:  Carol Ellinger Haddock, P.E. Deputy Director Engineering and Construction Division
----------------------------	-----------------------------	---

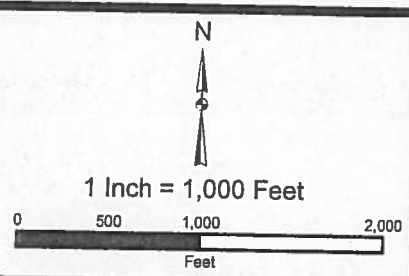
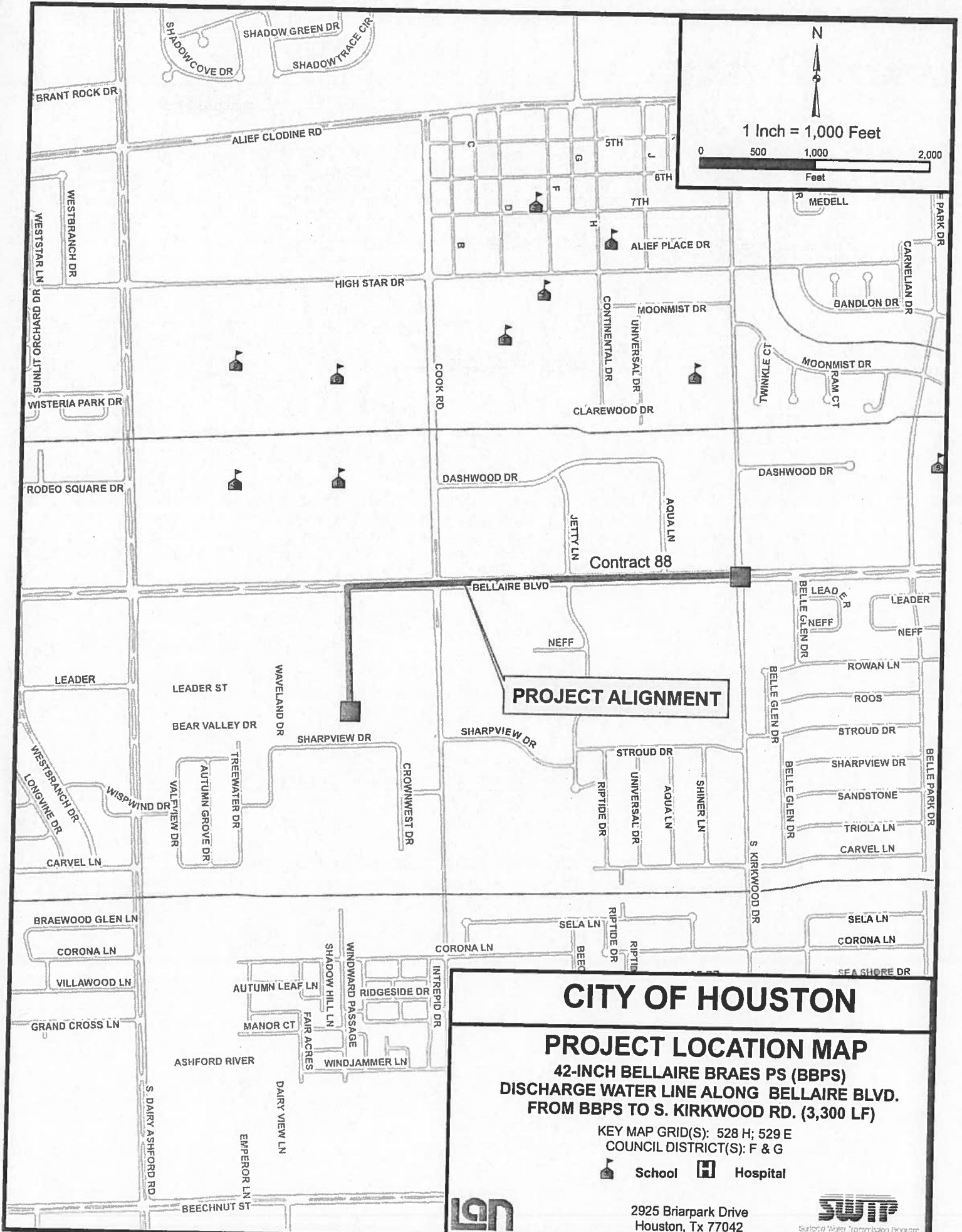

PROJECT ALIGNMENT

Contract 88

CITY OF HOUSTON

PROJECT LOCATION MAP
42-INCH BELLAIRE BRAES PS (BBPS)
DISCHARGE WATER LINE ALONG BELLAIRE BLVD.
FROM BBPS TO S. KIRKWOOD RD. (3,300 LF)

KEY MAP GRID(S): 528 H; 529 E
 COUNCIL DISTRICT(S): F & G

School Hospital

2925 Briarpark Drive
 Houston, Tx 77042





CITY OF HOUSTON - CITY COUNCIL

Meeting Date: 10/25/2016

District B

Item Creation Date: 10/12/2016

Lgl: Parcel KY14-069; Eminent domain; City v. Parkwood Baptist Church, et al., Cause#1065634; Northeast Transmission 108-inch Water Line Easement Acquisition Project;

Agenda Item#: 9.

Summary:

RECOMMENDATION from City Attorney to deposit the amount of the Award of Special Commissioners into the Registry of the Court and pay the costs of court and settle the case in connection with eminent domain proceedings styled City of Houston v. Parkwood Baptist Church, a Texas non-profit corporation, et al, Cause No. 1065634; for acquisition of Parcel KY14-069; for the **NORTHEAST TRANSMISSION 108-INCH WATER LINE EASEMENT ACQUISITION PROJECT (LEE RD - VICKERY DR.) - DISTRICT B - DAVIS**

Background:

The Northeast Transmission 108-inch Water Line Easement Acquisition Project (Lee Rd. - Vickery Dr.) is part of the City's regionalization program and is in compliance with the Harris-Galveston Subsidence District requirement to implement the City's long range water supply plan. The project provides for the design and construction of transmission and distribution lines to convey treated water from surface water facilities.

This eminent domain proceeding involves the acquisition of a water line easement containing 17,893 sf (0.4108 acre) of land from a parent tract containing 197,355 sf (4.5306 acres) of land located at 5301 Aldine Bender Road. The property is owned by Parkwood Baptist Church and is improved with a church facility and related appurtenances. The church facility is located outside of the area being acquired, but a fence and parking will be impacted by the City's acquisition.

City's Testimony Before the Special Commissioners: \$66,960.00 (i.e.\$24,603.00 for the land being acquired, \$29,985.00 for the improvements thereon and \$12,372.00 as damages in the form of cost-to-cure)

Award of Special Commissioners: \$75,000.00.

Court Costs: \$3,300.00 Special Commissioners' fees (i.e. \$1,100.00 x 3); \$340.00 Service of Process fee; \$3,625.00 Appraiser's fee **Total:** \$7,265.00. These court costs account for the monetary difference between the amount of the Award of Special Commissioners, and the total amount of funds needed herein.

It is recommended that the City Attorney be authorized by Motion to deposit the amount of the Award of Special Commissioners into the registry of the Court, pay the court costs and settle this case for the amount of the Award of Special Commissioners. Funding will be provided by a

previously approved blanket Appropriation Ordinance.

Prior Council Action:

Ordinance Number 2015-71, passed 1/28/15; Ordinance Number 2014-0307, passed 4/16/14;

Amount of Funding:

\$82,265.00; No additional funding required. (Funds previously appropriated under Ordinance No. 2014-307) Water and Sewer System Consolidated Construction Fund 8500.

Fiscal Note: There is no anticipated operating and maintenance impact associated with this site acquisition.

Contact Information:

Joseph N. Quintal

Phone: 832.393.6286

(alternatively Michelle Grossman 832.393.6216)

ATTACHMENTS:

Description



Request for Council Action

Type

Signed Cover sheet

TO: Mayor via City Secretary

REQUEST FOR COUNCIL ACTION

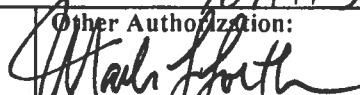
SUBJECT: Parcel KY14-069; City of Houston v. Parkwood Baptist Church, a Texas non-profit corporation, et al, Cause No. 1065634; Northeast Transmission 108-inch Water Line Easement Acquisition Project (Lee Rd - Vickery Dr.); WBS/CIP No. S-000900-0156-2-01; Legal Department File No. 081-1500027-002.		Page 1 of 1	Agenda Item #
FROM (Department or other point of origin): Legal Department - Real Estate Section Ronald C. Lewis, City Attorney		Origination Date 09/09/16	Agenda Date
DIRECTOR'S SIGNATURE:		Council District affected: "B"; Jerry Davis; Key Map No. 374Z	
For additional information contact: Joseph N. Quintal <i>JNQ</i> Phone: 832.393.6286 <i>GWD</i> (alternatively Michelle Grossman 832.393.6216)		Date and identification of prior authorizing Council action: Ordinance Number 2015-71, passed 1/28/15; Ordinance Number 2014-0307, passed 4/16/14;	
RECOMMENDATION: (Summary) Authorize the City Attorney, by Motion, to deposit the amount of the Award of Special Commissioners into the registry of the Court, pay the court costs, and settle the case for the amount of the Award of Special Commissioners. Funding will be provided by a previously approved blanket Appropriation Ordinance.			
Amount and Source of Funding: \$82,265.00; No additional funding required. (Funds previously appropriated under Ordinance No. 2014-307) Water and Sewer System Consolidated Construction Fund 8500. <i>M.P. 9/16/2016</i> Fiscal Note: There is no anticipated operating and maintenance impact associated with this site acquisition.			
SPECIFIC EXPLANATION: The Northeast Transmission 108-inch Water Line Easement Acquisition Project (Lee Rd. - Vickery Dr.) is part of the City's regionalization program and is in compliance with the Harris-Galveston Subsidence District requirement to implement the City's long range water supply plan. The project provides for the design and construction of transmission and distribution lines to convey treated water from surface water facilities. This eminent domain proceeding involves the acquisition of a water line easement containing 17,893 sf (0.4108 acre) of land from a parent tract containing 197,355 sf (4.5306 acres) of land located at 5301 Aldine Bender Road. The property is owned by Parkwood Baptist Church and is improved with a church facility and related appurtenances. The church facility is located outside of the area being acquired, but a fence and parking will be impacted by the City's acquisition. City's Testimony Before the Special Commissioners: \$66,960.00 (i.e.\$24,603.00 for the land being acquired, \$29,985.00 for the improvements thereon and \$12,372.00 as damages in the form of cost-to-cure) Award of Special Commissioners: \$75,000.00. Court Costs: \$3,300.00 Special Commissioners' fees (i.e. \$1,100.00 x 3); \$340.00 Service of Process fee; \$3,625.00 Appraiser's fee Total: \$7,265.00. These court costs account for the monetary difference between the amount of the Award of Special Commissioners, and the total amount of funds needed herein. It is recommended that the City Attorney be authorized by Motion to deposit the amount of the Award of Special Commissioners into the registry of the Court, pay the court costs and settle this case for the amount of the Award of Special Commissioners. Funding will be provided by a previously approved blanket Appropriation Ordinance.			
h:\mark\parkwoodbcrcra2.wpd			
REQUIRED AUTHORIZATION			
Other Authorization:  Dale A. Rudick, P.E., Director Public Works and Engineering	Other Authorization:  Jun Chang, P.E., D WRE, Deputy Director Public Utilities Division, PWE	Other Authorization:  Mark L. Loethen, P.E. CFM, Deputy Director Planning and Development Services Division, PWE	<i>90AH312</i>



CITY OF HOUSTON - CITY COUNCIL

Meeting Date: 10/25/2016

ALL

Item Creation Date: 8/23/2016

H25925 - Software Maintenance and Support Services for the Electronic Citation Software PocketCitation™ - MOTION

Agenda Item#: 10.

Summary:

ADVANCED PUBLIC SAFETY for Software Maintenance and Support Services for the Electronic Citation Software PocketCitation™ for the Houston Police Department - 1 Year \$143,769.59 - General Fund

Background:

S17-H25925 - Approve the sole source purchase of software maintenance and support services for the electronic citation software PocketCitation™ in the total amount of \$143,769.59 for the Houston Police Department.

Specific Explanation:

The Acting Chief of the Houston Police Department (HPD) and the Chief Procurement Officer recommend that City Council approve the sole source purchase of software maintenance and support services for 12 months for the electronic citation software PocketCitation™ in the total amount of **\$143,769.59** for HPD and that authorization be given to issue purchase orders to **Advanced Public Safety.**

Advanced Public Safety (APS) provides HPD electronic citation writer PocketCitation™ software maintenance with fixes, upgrades, and assistance. Additionally, APS provides the maintenance of the handheld ticket writer devices that run the PocketCitation™ software and the mobile printers that allows printing of the electronic citations given to citizens.

The PocketCitation™ system provides officers an electronic method of writing citations on handheld devices and transferring the citations electronically to the Municipal Courts for processing. This eliminates paper copies and manual effort to enter and process the citations.

Advanced Public Safety is the sole distributor of the software components associated with the PocketCitation™ system and sole service provider for this technology.

This recommendation is made pursuant to Chapter 252, Section 252.022 (a) (7) (A) "a procurement of items that are available from only one source, including: items that are available from only one source because of patents, copyrights, secret processes, or natural monopolies" of the Texas Local Government Code for exempted procurements.

M/WBE Participation:

M/WBE Zero-Percentage Goal document approved by the Office of Business of Opportunity.

Hire Houston First:

This procurement is exempt from the City’s Hire Houston First Ordinance. Bids/proposals were not solicited because the department is utilizing a sole source for this purchase

Fiscal Note:

Funding for this item is included in the FY2017 Adopted Budget. Therefore, no Fiscal Note is required as stated in the Financial Policy Ord. 2014-1078.

John J. Gillespie, Chief Procurement Officer
Signature
Finance/Strategic Procurement Division

Department Approval Authority

Amount of Funding:

\$143,769.59 - General Fund (1000)

Contact Information:

NAME:	DEPARTMENT/ DIVISION	PHONE
Joseph A. Fenninger, CFO & Deputy Director	HPD	(713) 308-1770
Martin King, Division Manager	FIN/SPD	(832) 393-8705
Murdock Smith, Sr. Procurement Specialist	FIN/SPD	(832) 393-8725

ATTACHMENTS:

Description

Cover Sheet

Type

Signed Cover sheet



CITY OF HOUSTON - CITY COUNCIL

Meeting Date: 9/20/2016

ALL

Item Creation Date: 8/23/2016

H25925 - Software Maintenance and Support Services for the Electronic Citation Software PocketCitation™ - MOTION

Agenda Item#: 15.

Background:

S17-H25925 - Approve the sole source purchase of software maintenance and support services for the electronic citation software PocketCitation™ in the total amount of \$143,769.59 for the Houston Police Department.

Specific Explanation:

The Acting Chief of the Houston Police Department (HPD) and the Chief Procurement Officer recommend that City Council approve the sole source purchase of software maintenance and support services for 12 months for the electronic citation software PocketCitation™ in the total amount of \$143,769.59 for HPD and that authorization be given to issue purchase orders to **Advanced Public Safety**.

Advanced Public Safety (APS) provides HPD electronic citation writer PocketCitation™ software maintenance with fixes, upgrades, and assistance. Additionally, APS provides the maintenance of the handheld ticket writer devices that run the PocketCitation™ software and the mobile printers that allows printing of the electronic citations given to citizens.

The PocketCitation™ system provides officers an electronic method of writing citations on handheld devices and transferring the citations electronically to the Municipal Courts for processing. This eliminates paper copies and manual effort to enter and process the citations.

Advanced Public Safety is the sole distributor of the software components associated with the PocketCitation™ system and sole service provider for this technology.

This recommendation is made pursuant to Chapter 252, Section 252.022 (a) (7) (A) "a procurement of items that are available from only one source, including: items that are available from only one source because of patents, copyrights, secret processes, or natural monopolies" of the Texas Local Government Code for exempted procurements.

M/WBE Participation:

M/WBE Zero-Percentage Goal document approved by the Office of Business of Opportunity.

Hire Houston First:

This procurement is exempt from the City's Hire Houston First Ordinance. Bids/proposals were not solicited because the department is utilizing a sole source for this purchase

Fiscal Note:

Funding for this item is included in the FY2017 Adopted Budget. Therefore, no Fiscal Note is required as stated in the Financial Policy Ord. 2014-1078.

John J. Gillespie, Chief Procurement Officer
Finance/Strategic Procurement Division

Department Approval Authority Signature

Amount of Funding:

\$143,769.59 - General Fund (1000)

Contact Information:

NAME:	DEPARTMENT/ DIVISION	PHONE
Joseph A. Fenninger, CFO & Deputy Director	HPD	(713) 308-1770
Martin King, Division Manager	FIN/SPD	(832) 393-8705
Murdock Smith, Sr. Procurement Specialist	FIN/SPD	(832) 393-8725

ATTACHMENTS:

Description	Type
-------------	------

[OBO Document](#)
[Form A](#)
[Form B](#)
[Deliquent Tax Report](#)
[Affidavit of Ownership](#)
[Fiscal Note](#)

Backup Material
Backup Material
Backup Material
Backup Material
Backup Material
Backup Material



CITY OF HOUSTON - CITY COUNCIL

Meeting Date: 10/25/2016

ALL

Item Creation Date: 10/10/2016

20DM21 Professional Services/Spending Authority/INFOR
Public Sector, Inc.

Agenda Item#: 11.

Summary:

INFOR PUBLIC SECTOR, INC for approval of spending authority in the amount not to exceed \$995,000.00 for purchase of Professional Services for Department of Public Works & Engineering Enterprise and Other Funds

Background:

SUBJECT: Request for approval of spending authority for INFOR Public Sector, Inc., for the purchase of Professional Services in the amount not to exceed \$995,000.00.

RECOMMENDATION: (Summary) Approve spending authority for the purchase of INFOR Professional Services in an amount not to exceed \$995,000.00.

SPECIFIC EXPLANATION: The Director of the Department of Public Works & Engineering recommends that the City Council approve spending authority to issue purchase orders to INFOR Public Sector, Inc. for the purchase of professional services in an amount not to exceed \$995,000.00.

On March 1, 2011 the Director of Public Works and Engineering Department presented to the Budget and Fiscal Affairs Committee the department's plan to replace its legacy 25-year old Water Billing and Customer Information System (WCIS) with a web based user interfaced solution; INFOR Public Sector, Inc. INFOR (Hansen) CIS Utility Billing is a modernized Water, Sewer, and Drainage Customer Information and Billing System and was launched on May 1, 2016. The Professional Services being requested include final stabilization of the new billing system, risk management, business continuity initiatives, bill print and mailing services. The new bill print and mailing service will result in \$1.4M savings over three (3) years compared to current pricing.

This item was presented to the Transportation, Technology and Infrastructure Committee on October 17, 2016.

Pay or Play: The proposed contracts require compliance with the City's "Pay or Play" ordinance regarding health benefits for employees of City contractors. In this case, INFOR Public Sector, Inc. provides health benefits to eligible employees in compliance with City policy has elected to both pay and to play into the Contractor Responsibility Fund and provide health benefits to eligible employees in compliance with City policy.

MWBE Participation: Zero-Percentage Goal document approved by the Office of Business Opportunity.

Fiscal Note:

Funding for this item is included in the FY'17 Adopted Budget. Therefore, No Fiscal Note is required as stated in the Financial Policy Ord. No.: 2014-1078

Dale A. Rudick, P.E., Director
Department of Public Works and Engineering

Prior Council Action:

Ordinance 2015-0256, dated 04/15/2015

Ordinance 2014-0441, dated 05/28/2014

Amount of Funding:

Spending Authority: \$995,000.00

\$804,030.00 Combined Utility System General Purpose Fund (8305)

\$190,970.00 Water & Sewer System Operating Fund (8300)

Contact Information:

Sherri Winslow (832) 395-6377

David Guernsey (832) 395-3640

ATTACHMENTS:

Description

RCA (revised)

Type

Signed Cover sheet

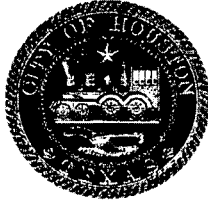

CITY OF HOUSTON - CITY COUNCIL

Meeting Date: 10/25/2016

ALL

Item Creation Date: 10/10/2016

20DM21 Professional Services/Spending Authority/INFOR Public Sector, Inc.

Agenda Item#: 22.

Summary:

Not Real Caption

Request for approval of spending authority for INFOR Public Sector, Inc., for the purchase of Professional Services in the amount not to exceed \$995,000.00.

Background:

SUBJECT: Request for approval of spending authority for INFOR Public Sector, Inc., for the purchase of Professional Services in the amount not to exceed \$995,000.00.

RECOMMENDATION: (Summary) Approve spending authority for the purchase of INFOR Professional Services in an amount not to exceed \$995,000.00.

SPECIFIC EXPLANATION: The Director of the Department of Public Works & Engineering recommends that the City Council approve spending authority to issue purchase orders to INFOR Public Sector, Inc. for the purchase of professional services in an amount not to exceed \$995,000.00.

On March 1, 2011 the Director of Public Works and Engineering Department presented to the Budget and Fiscal Affairs Committee the department's plan to replace its legacy 25-year old Water Billing and Customer Information System (WCIS) with a web based user interfaced solution; INFOR Public Sector, Inc. INFOR (Hansen) CIS Utility Billing is a modernized Water, Sewer, and Drainage Customer Information and Billing System and was launched on May 1, 2016. The Professional Services being requested include final stabilization of the new billing system, risk management, business continuity initiatives, bill print and mailing services. The new bill print and mailing service will result in \$1.4M savings over three (3) years compared to current pricing.

This item was presented to the Transportation, Technology and Infrastructure Committee on October 17, 2016.

Pay or Play: The proposed contracts require compliance with the City's "Pay or Play" ordinance regarding health benefits for employees of City contractors. In this case, INFOR Public Sector, Inc. provides health benefits to eligible employees in compliance with City policy has elected to both pay and to play into the Contractor Responsibility Fund and provide health benefits to eligible employees in compliance with City policy.

M/WBE Participation: Zero-Percentage Goal document approved by the Office of Business Opportunity.

Fiscal Note:

Funding for this item is included in the FY'17 Adopted Budget. Therefore, No Fiscal Note is required as stated in the Financial Policy Ord. No.: 2014-1078

Dale A. Rudick, P.E., Director
Department of Public Works and Engineering

Prior Council Action:

Ordinance 2015-0256, dated 04/15/2015

Ordinance 2014-0441, dated 05/28/2014

Amount of Funding:

Spending Authority: \$995,000.00

\$804,030.00 Combined Utility System General Purpose Fund (8305)

\$190,970.00 Water & Sewer System Operating Fund (8300)

Contact Information:



CITY OF HOUSTON - CITY COUNCIL

Meeting Date: 10/25/2016

ALL

Item Creation Date: 9/21/2016

N25896 - Appropriation - ORDINANCE - Vans

Agenda Item#: 12.

Summary:

ORDINANCE appropriating \$37,826.00 out of Fleet Equipment Special Revenue Fund for the purchase of Transit and Cargo Vans for the Fleet Management Department

Background:

S38-N25896 - Approve an ordinance appropriating the sum of \$37,826.00 out of the Fleet Equipment Special Revenue Fund for the purchase of transit and cargo vans for the Fleet Management Department.

Specific Explanation:

The Director of the Fleet Management Department and the Chief Procurement Officer recommend that City Council approve an ordinance authorizing the appropriation of **\$37,826.00** out of the Fleet Equipment Special Revenue Fund (9002) for the purchase of two transit vans. **The funding for these vehicles is included in the adopted FY17 Equipment Acquisition Plan.**

Fiscal Note:

There is no estimated impact to the operating and maintenance costs as a result of this CIP project. Therefore, no Fiscal Note is required as stated in the Financial Policy Ord. 2014-1078.

John J. Gillespie, Chief Procurement Officer

Signature

Finance/Strategic Procurement Division

Department Approval Authority

Amount of Funding:

\$37,826.00 - Fleet Equipment Special Revenue Fund (9002)

Contact Information:

Jedediah Greenfield

832-393-6910

Desiree Heath

832-393-8742

Lena Farris

832-393-8729

ATTACHMENTS:

Description

Appropriating RCA

Type

Signed Cover sheet



CITY OF HOUSTON - CITY COUNCIL

Meeting Date: 10/11/2016

ALL

Item Creation Date: 9/21/2016

N25896 - Appropriation - ORDINANCE

Agenda Item#: 10.

Summary:

Background:

S38-N25896 - Approve an ordinance appropriating the sum of \$37,826.00 out of the Fleet Equipment Special Revenue Fund for the purchase of transit and cargo vans for the Fleet Management Department.

Specific Explanation:

The Director of the Fleet Management Department and the Chief Procurement Officer recommend that City Council approve an ordinance authorizing the appropriation of \$37,826.00 out of the Fleet Equipment Special Revenue Fund (9002) for the purchase of two transit vans. The funding for these vehicles is included in the adopted FY17 Equipment Acquisition Plan.

Fiscal Note:

Funding for this item is included in the FY17 Adopted Budget. Therefore, no Fiscal Note is required as stated in the Financial Policy Ord. 2014-1078.

John J. Gillespie, Chief Procurement Officer
Finance/Strategic Procurement Division

Department Approval Authority Signature

Amount of Funding:

\$37,826.00 - Fleet Equipment Special Revenue Fund (9002)

Contact Information:

Jedediah Greenfield	832-393-6910
Desiree Heath	832-393-8742
Lena Farris	832-393-8729

ATTACHMENTS:

Description	Type
<u>N25896 B & H Appropriating Ordinance</u>	Backup Material
<u>N25896 B & H RCA Funding Information- FMD 9002</u>	Financial Information



CITY OF HOUSTON - CITY COUNCIL

Meeting Date: 10/25/2016

ALL

Item Creation Date: 8/22/2016

N25896.1 - Vans - MOTION

Agenda Item#: 13.

Summary:

SILSBEE FORD, INC - \$424,354.33, **CALDWELL AUTOMOTIVE PARTNERS LLC, D/B/A CALDWELL COUNTRY CHEVROLET, LLC** - \$175,370.00, **COWBOY DODGE** - \$201,840.01, for Transit and Cargo Vans through the Interlocal Agreement for Cooperative Purchasing with the Houston-Galveston Area Council and the Texas Local Government Purchasing Cooperative (BuyBoard) for Various Departments - \$801,564.34 - Equipment Acquisition Consolidated, Fleet Equipment Special Revenue Fund and Other Funds

This item should only be considered after passage of Item 12 above

Background:

S38-N25896.1 - Approve the purchase of vans through the Houston-Galveston Area Council (H-GAC) and the Texas Local Government Purchasing Cooperative (BuyBoard) in the total amount of \$801,564.34 for various departments.

Specific Explanation:

The Director of the Fleet Management Department and the Chief Procurement Officer recommend that City Council approve the purchase of transit and cargo vans through the Interlocal Agreement for Cooperative Purchasing with the Houston-Galveston Area Council (H-GAC) and the Texas Local Government Purchasing Cooperative (Buyboard) **in the total amount of \$801,564.34** for various departments and that authorization be given to issue purchase orders to the cooperative purchasing agencies contractors, as shown below. These vehicles will be used citywide by department personnel to conduct City business and provide services to the citizens of Houston. **The funding for these vehicles is included in the adopted FY17 Equipment Acquisition Plan.**

H-GAC Contractors:

Silsbee Ford, Inc.: Approve the purchase of twelve transit 4-cylinder transit connect vans, one 12-passenger van, and five 15 - passenger vans in the amount of **\$424,354.33**.

Caldwell Automotive Partners LLC, d/b/a Caldwell Country Chevrolet, LLC: Approve the purchase of five cargo vans and three extended cargo vans in the amount of **\$175,370.00**.

Buyboard Contractor:

Cowboy Dodge: Approve the purchase of nine 7-passenger cargo vans in the amount of **\$201,840.01.**

These vans will come with a full three-year/36,000 miles bumper-to-bumper warranty. The life expectancy of these vehicles is seven years or 100,000 miles. The new vehicles will meet EPA's current emission standards for low emission vehicles. The vehicles that are being purchased will replace units that have reached their life expectancy and will be sent to auction for disposition.

M/WBE Participation:

M/WBE Zero Percentage Goal Document approved by the Office of Business Opportunity.

Hire Houston First:

The procurement is exempt from the City's Hire Houston First Ordinance. Bids/proposals were not solicited because the department is utilizing an Interlocal Agreement for this purchase.

Fiscal Note:

There is no estimated impact to the operating and maintenance costs as a result of this CIP project. Therefore, no Fiscal Note is required as stated in the Financial Policy Ord. 2014-1078.

John J. Gillespie, Chief Procurement Officer
Signature
Finance/Strategic Procurement Division

Department Approval Authority

Prior Council Action:

Appropriation Ordinance 2016-0688 approved by City Council 09/07/2016

Amount of Funding:

\$218,972.00 - Equipment Acquisition Consolidated Fund (1800)
\$ 40,445.34 - Stormwater Fund (2302)
\$165,367.00 - Dedicated Drainage & Street Renewal Fund (2310)
\$ 19,213.00 - HAS-AIF Capital Outlay Fund (8012)
\$221,542.00 - Combined Utility System General Purpose Fund (8305)
\$ 37,826.00 - Fleet Equipment Special Revenue Fund (9002)
\$ 98,199.00 - Parking Management Fund (8700)
\$801,564.34 - Total Funding

Contact Information:

Jedediah Greenfield	832-393-6910
Desiree Heath	832-393-8742
Lena Farris	832-393-8729

ATTACHMENTS:

Description	Type
RCA#N25896.1 purchase RCA	Signed Cover sheet



CITY OF HOUSTON - CITY COUNCIL

Meeting Date: 10/11/2016

ALL

Item Creation Date: 8/22/2016

N25896.1 - Vans - MOTION

Agenda Item#: 2.

Background:

S38-N25896.1 - Approve the purchase of vans through the Houston-Galveston Area Council (H-GAC) and the Texas Local Government Purchasing Cooperative (BuyBoard) in the total amount of \$801,564.34 for various departments.

Specific Explanation:

The Director of the Fleet Management Department and the Chief Procurement Officer recommend that City Council approve the purchase of transit and cargo vans through the Interlocal Agreement for Cooperative Purchasing with the Houston-Galveston Area Council (H-GAC) and the Texas Local Government Purchasing Cooperative (Buyboard) in the total amount of \$801,564.34 for various departments and that authorization be given to issue purchase orders to the cooperative purchasing agencies contractors, as shown below. These vehicles will be used citywide by department personnel to conduct City business and provide services to the citizens of Houston. The funding for these vehicles is included in the adopted FY17 Equipment Acquisition Plan.

H-GAC Contractors:

Silsbee Ford, Inc.: Approve the purchase of twelve transit 4-cylinder transit connect vans, one 12- passenger van, and five 15 - passenger vans in the amount of \$424,354.33.

Caldwell Automotive Partners LLC, d/b/a Caldwell Country Chevrolet, LLC: Approve the purchase of five cargo vans and three extended cargo vans in the amount of \$175,370.00.

Buyboard Contractor:

Cowboy Dodge: Approve the purchase of nine 7-passenger cargo vans in the amount of \$201,840.01.

These vans will come with a full three-year/36,000 miles bumper-to-bumper warranty. The life expectancy of these vehicles is seven years or 100,000 miles. The new vehicles will meet EPA's current emission standards for low emission vehicles. The vehicles that are being purchased will replace units that have reached their life expectancy and will be sent to auction for disposition.

M/WBE Participation:

M/WBE Zero Percentage Goal Document approved by the Office of Business Opportunity.

Hire Houston First:

The procurement is exempt from the City's Hire Houston First Ordinance. Bids/proposals were not solicited because the department is utilizing an Interlocal Agreement for this purchase.

Fiscal Note:

Funding for this item is included in the FY17 Adopted Budget. Therefore, no Fiscal Note is required as stated in the Financial Policy Ord. 2014-1078.

John J. Gillespie, Chief Procurement Officer
Finance/Strategic Procurement Division

Department Approval Authority Signature

Prior Council Action:

Appropriation Ordinance 2016-0688 approved by City Council 09/07/2016

Amount of Funding:

\$218,972.00 - Equipment Acquisition Consolidated Fund (1800)
\$ 40,445.34 - Stormwater Fund (2302)
\$165,367.00 - Dedicated Drainage & Street Renewal Fund (2310)
\$ 19,213.00 - HAS-AIF Capital Outlay Fund (8012)
\$221,542.00 - Combined Utility System General Purpose Fund (8305)
\$ 37,826.00 - Fleet Equipment Special Revenue Fund (9002)
\$ 98,199.00 - Parking Management Fund (8700)
\$801,564.34 - Total Funding

Contact Information:

Jedediah Greenfield	832-393-6910
Desiree Heath	832-393-8742
Lena Farris	832-393-8729

ATTACHMENTS:

Description	Type
<u>N25896 B & H Silsbee Delinquent Tax</u>	Backup Material
<u>N25896 - B & H Silsbee Fair Campagin</u>	Backup Material
<u>N25896 B & H Silsbee Affidavit of Ownership</u>	Backup Material
<u>Ordinance 2016-0688</u>	Backup Material
<u>N25896 B & H Caldwell Deliquent Tax Report</u>	Backup Material
<u>N25896 B & H Caldwell Fair Campagin</u>	Backup Material
<u>N25896 B & H Caldwell Delinquent Tax Report</u>	Backup Material
<u>N25896 B & H Form B</u>	Backup Material
<u>N25896 B & H Cowboy Fair Campagin</u>	Backup Material
<u>N25896 B & H Ownership Information</u>	Backup Material
<u>N25896 B & H RCA Funding Information ARA</u>	Backup Material
<u>N25896 B & H RCA Funding Information PWE</u>	Backup Material
<u>N25896 B & H RCA Funding Information P & R</u>	Backup Material
<u>N25896 B & H RCA Funding Information HHS</u>	Backup Material
<u>N25896 B & H RCA Funding Information HITS</u>	Backup Material
<u>N25896 B & H RCA Funding Information Library</u>	Backup Material
<u>N25896 B & H RCA Funding Information HFD</u>	Backup Material
<u>N25896 B & H Price Comparsion</u>	Backup Material
<u>N25896 B & H OBO Documents</u>	Backup Material
<u>N25896 B & H RCA Funding Information FMD</u>	Backup Material
<u>N25896 B & H RCA Funding Information FMD 9002</u>	Backup Material



CITY OF HOUSTON - CITY COUNCIL

Meeting Date: 10/25/2016

Item Creation Date:

Pension Resolution

Agenda Item#: 14.

Summary:

RESOLUTION in support of the City's plan to reform the City's three Pension Systems, the Houston Police Officers' Pension System, the Houston Municipal Employees Pension System, and the Houston Firefighters' Relief and Retirement Fund, to ensure long-term, secure, and dependable retirement systems

Background:

The Administration has worked with representatives of the Houston Municipal Employees Retirement System, the Houston Police Officers Pension System, and the Houston Firefighters' Relief and Retirement Fund since January to develop comprehensive pension reform for the City of Houston. If approved, this resolution of support will express Council's endorsement of the plan negotiated by Mayor Turner and City staff. Details are included in term sheets attached to the resolution.

Kelly Dowe
Chief Business Officer

Contact Information:

Kelly Dowe 832.393.9051
Jennifer Olenick 832.393.9112

ATTACHMENTS:

Description	Type
Pension subcommittee presentaion	Backup Material



City of Houston

Presentation to the City Council Budget and Fiscal Affairs Committee Subcommittee on Pensions and Debt Service

Sustainable City of Houston Pensions

October 20, 2016

**Kelly Dowe, Chief Business Officer/Director of Finance
Ronald C. Lewis, City Attorney
Jennifer Olenick, CFA, Deputy Director of Finance**

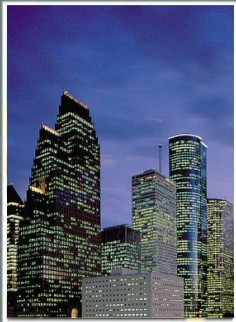

Overview

- Background
 - Mayor's commitment
 - Months of meetings
- Choosing a path: Defined benefit vs. defined contribution
- The City's plan
 - A clear look at what the City owes
 - Reduce the liability
 - Manage costs going forward
- What about pension obligation bonds (POBS)?
- The corridor
- Next steps

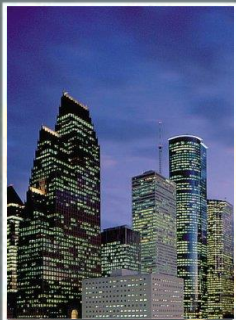

Background

- Mayor Turner committed to pension reform as a candidate for mayor, and has made it a priority
- Three objectives for now and in the future
 - Achieve cost avoidance and budget neutrality
 - Reduce unfunded liability
 - Achieve a solution that removes pension issues from the table
- Employees and taxpayers deserve a pension system that is fair, affordable and sustainable
- Shared sacrifice is required to meet the objectives
- Began meeting with pension system representatives in January 2016
- Meetings have continued over the past nine months and into this week

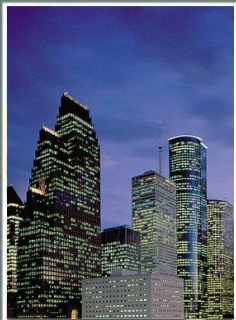

Choosing a Path: DB vs. DC

- Mayor's commitment: achieve sustainable, affordable reform while protecting defined-benefit pensions
- Shift to defined contributions would do nothing to reduce \$7.8 billion of pension liability
 - Would only slow its growth
- All three pension systems oppose shift to defined-contribution approach
 - Unlike the City's plan, DC proposal would achieve no negotiated reductions to current pension liability

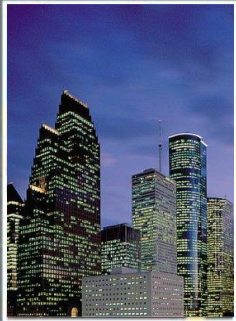

Choosing a Path: DB vs. DC

- Defined-contribution pensions could harm the City as an employer
 - Likely to prompt wave of retirements (nearly 2,000 police officers eligible right now)
 - Could also diminish City's appeal for prospective employees (most Texas cities offer a plan that provides some certainty regarding future benefits)
- In the long run, the proposed reform is more affordable
 - Without \$2.5 billion of benefit changes, the \$7.8 billion net pension liability costs 49 percent of payroll
 - The cost of the new DC plan would be in addition to this 49 percent
 - The \$7.8 billion could grow without limit in the absence of the corridor to manage costs

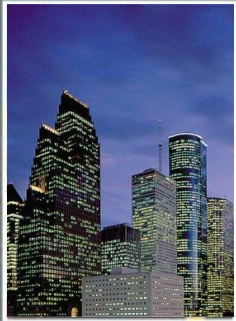

The City's Plan: What is owed?

- First step: Get a clearer look at what we owe
- Requires more accurate calculation of City's net pension liability
 - Reduce anticipated rate of return (i.e., discount rate) for all three systems to 7 percent
 - Recognize all investment gains and losses as of June 30, 2016
- Impact: Increase City's pension liability from \$5.6 billion to \$7.8 billion

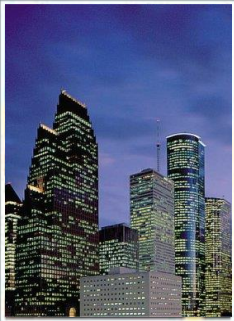

The City's Plan: What is owed?

2016 NPL – Before Benefit Reform

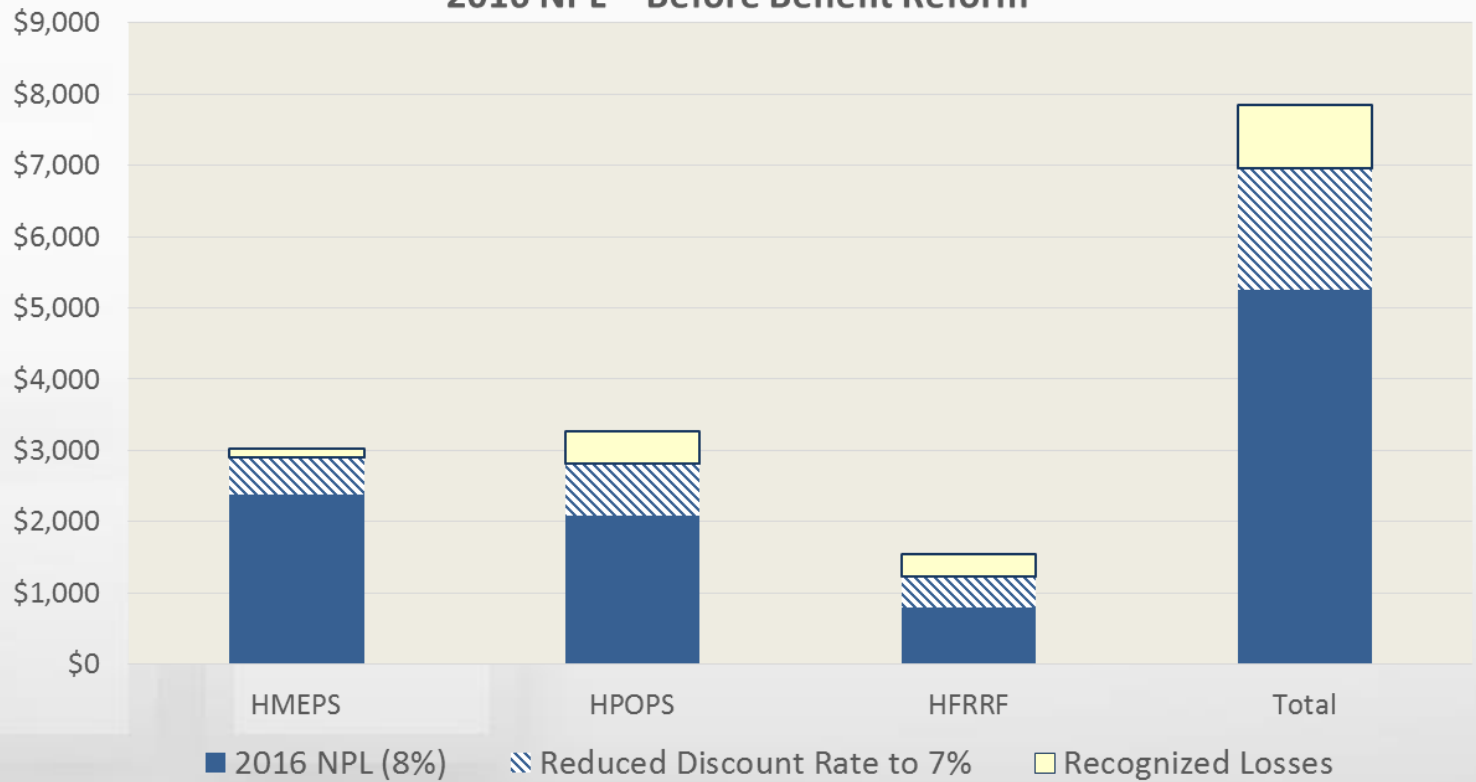

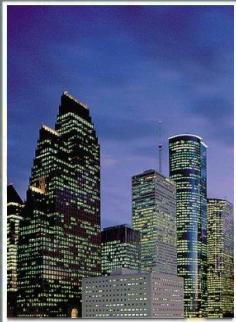

The City's Plan: Reduce liability

- Second step: Reduce the City's pension liability
 - Benefit adjustments in all three systems to reduce future costs: liability reduction of \$2.5 billion
 - City addresses past underfunding with issuance of \$1 billion in POBs
 - HMEPS (\$250 million) and HPOPS (\$750 million)
 - City required to make full annual contributions to each system: no more long-term underfunding
- Impact: Total immediate reduction in net pension liability of \$3.5 billion

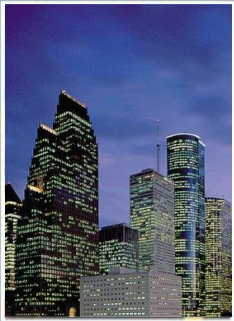

The City's Plan: Reduce liability

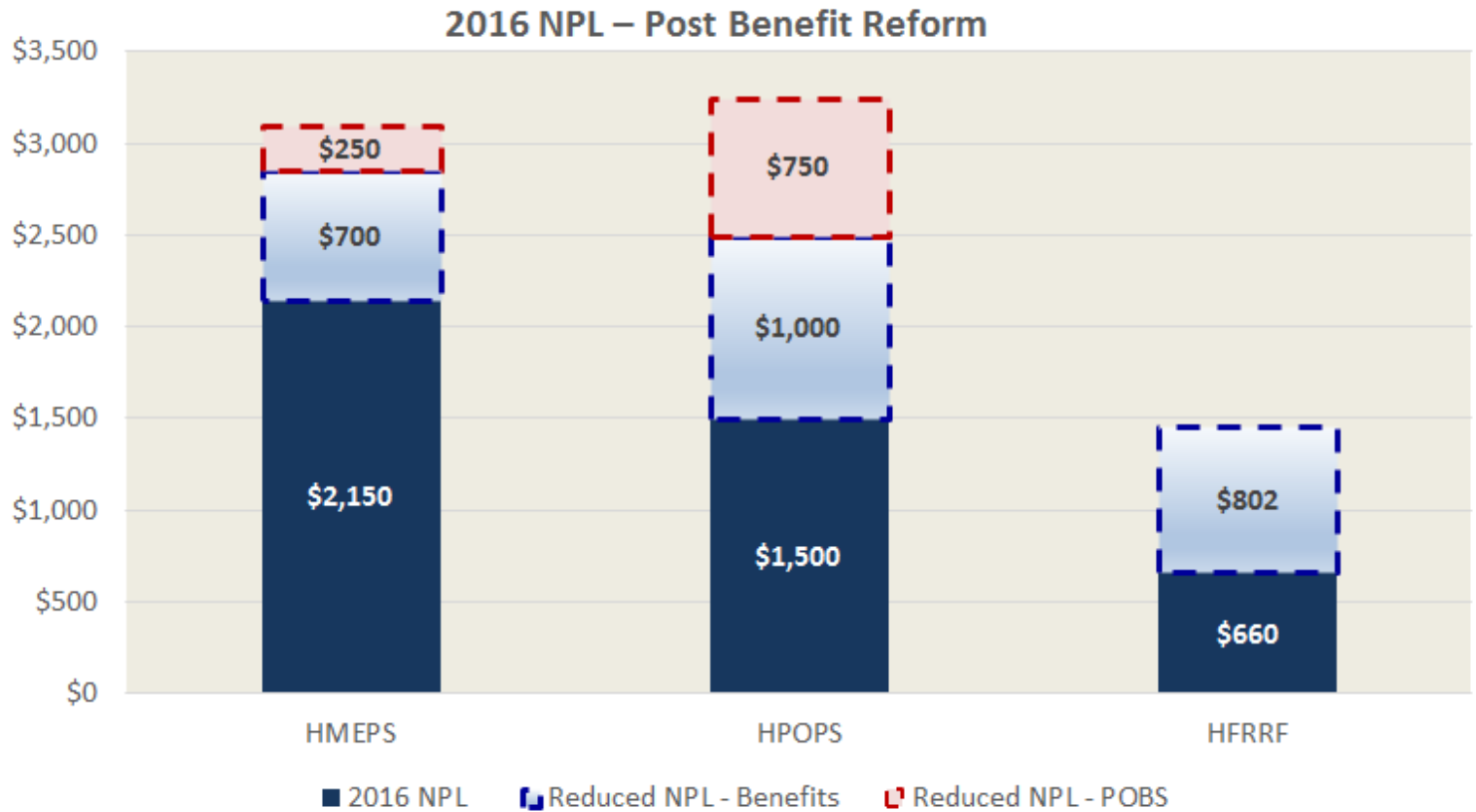

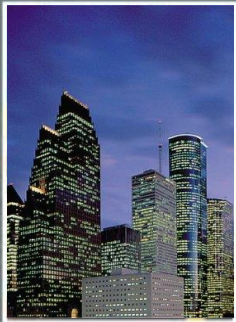

The City's Plan: Manage costs

- Third step: Better management of pension costs and liability in the future
 - Closed 30-year amortization sets clear schedule and hard date for payoff: no more “kicking the can”
 - Corridor sets City contribution boundaries that trigger pension system changes if breached

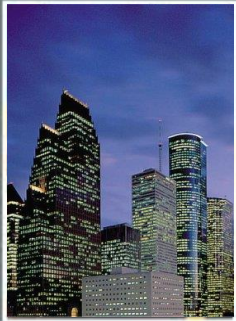

The City's Plan: What about POBs?

- Without POBs, there is no deal
 - City has underfunded HMEPS and HPOPS for years; both systems required infusion of cash as condition of reform
- Markets' concern is using POBs to replace contributions in a given year – we don't do that
 - Fitch: "POB use in conjunction with reforms to benefits and contribution practices increases the odds of strengthening funding positions and improving long-term sustainability." (Sept. 2016)

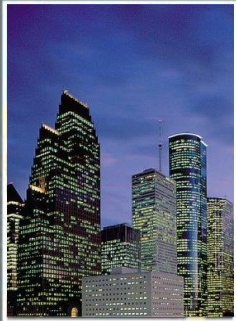

The City's Plan: What about POBs?

- POBs do not incur additional debt for the City
- City already owes the \$1 billion to pension systems
- POBs do not increase the total amount the City owes
 - Before POBs pension liability with reform is \$5.3 billion
 - After POBs, pension liability with reform is \$4.3 billion and debt obligations increase by \$1.0 billion
 - Total amount owed is still \$5.3 billion



The City's Plan: The corridor

Overview of Risk Sharing

The Corridor is a cost management mechanism designed to ensure plan sustainability

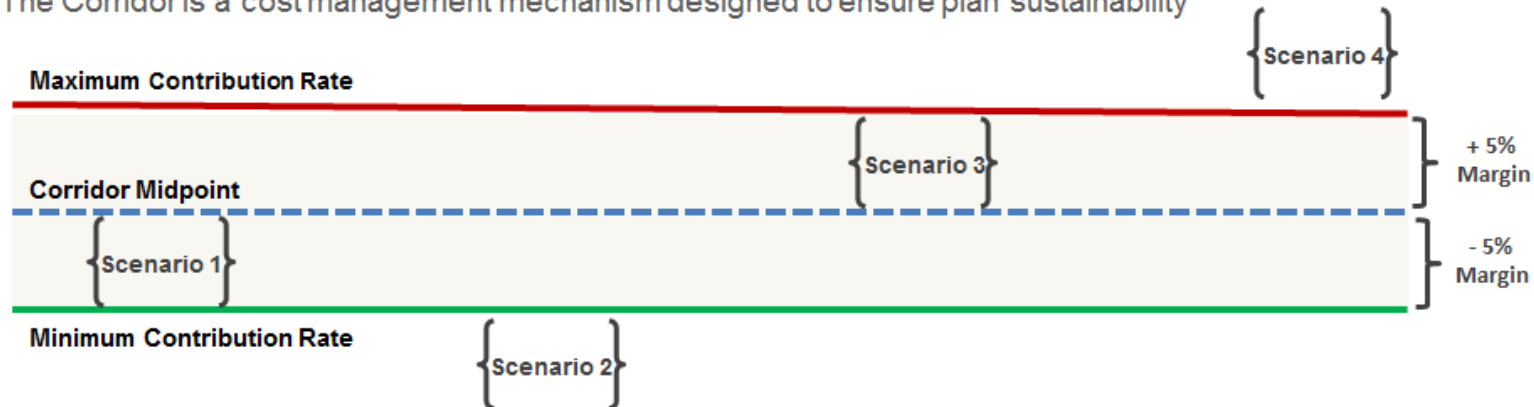

Declining Pension Costs

Scenario 1: Inside Corridor – between Midpoint and Minimum

- City Contribution Rate is in between Minimum and Midpoint
- City over funds, creating cushion for future
- Return to the Midpoint (if <90% funded)

Scenario 2: Outside Corridor – Below Minimum

- City Contribution Rate is below Minimum
- Pay down pension liability faster
- Take risk of underfunding off the table (by lowering assumed rate of return)

Rising Pension Costs

Scenario 3: Inside Corridor – between Midpoint and Maximum

- City Contribution Rate is in between the Midpoint and the Maximum
- Risk of increasing pension costs are paid by the City

Scenario 4: Outside Corridor – above Maximum

- City Contribution Rate is above the Maximum
- Use cushion, if any, built in Scenario 1, prior to remedies, to decrease City Contribution to Midpoint
- Ensures costs remain sustainable

Corridor Midpoint = proposed benefits package estimated cost



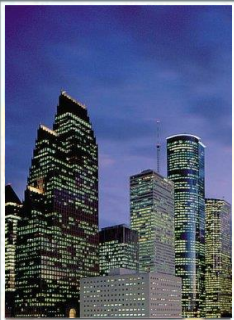

The City's Plan: The corridor

Scenario 1: Declining Pension Costs

If City Contribution Rate is between the Minimum and Corridor Midpoint,

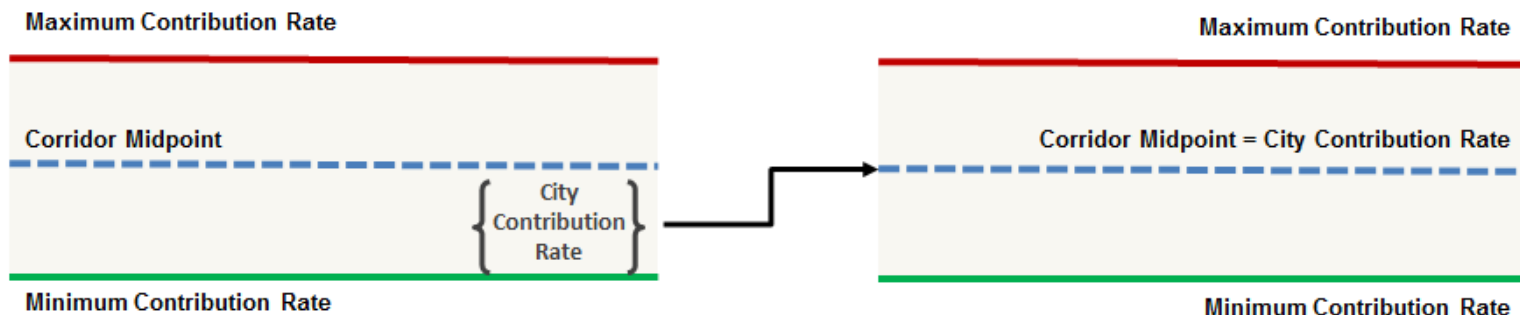

then the City shall take the following actions in listed order to bring the City Contribution Rate back to Corridor Midpoint

and Funded Ratio < 90%, then:

1. Over fund at the Corridor Midpoint.

UNLESS Funded Ratio ≥ 90%, then:

1. No remedies are undertaken, City pays City Contribution Rate (which will remain in between Midpoint and Minimum).

These remedies use gains to improve the systems' financial strength

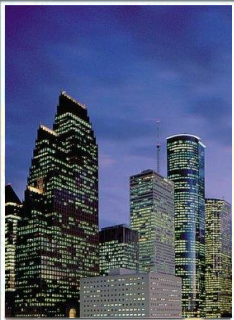

The City's Plan: The corridor

Scenario 2: Declining Pension Costs

If City Contribution Rate is less than Minimum Contribution Rate,

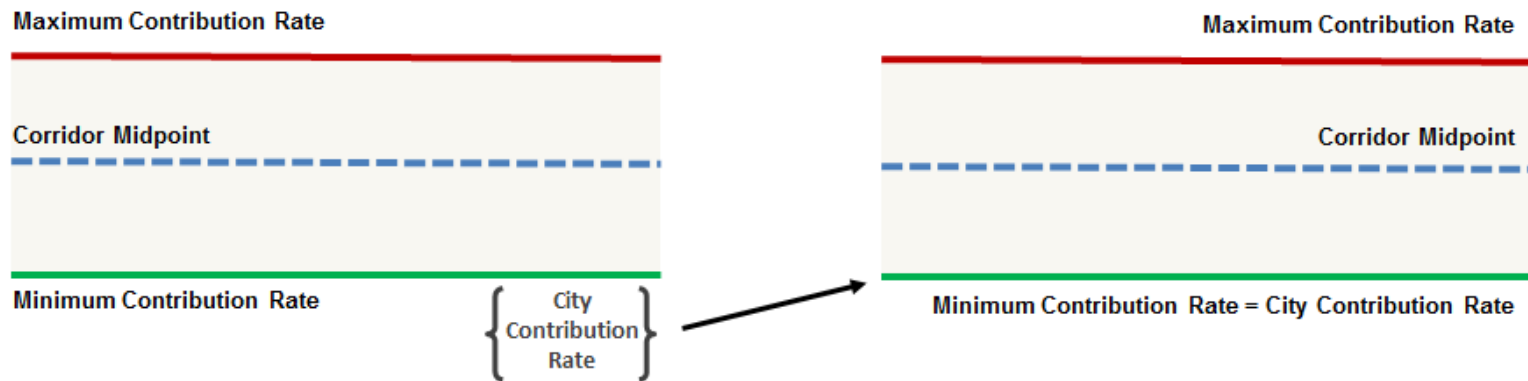

then the City shall take the following actions in listed order until the City Contribution Rate equals the Minimum Contribution Rate

1. Prospectively, restore all or portion(s) of benefit cuts, if any, made subsequent to this agreement as a result of this Risk Sharing Provision.
2. Accelerate the payoff of the unfunded liability, but to no less than 20 years from inception of liability layer.
3. Take risk off the table by reducing the Discount Rate.
4. If the Funded Ratio is less than 90%, the City shall pay the Corridor Midpoint.
5. If the Funded Ratio is between 90% and 100%, the City shall pay the Minimum Contribution Rate.
6. If the Funded Ratio is at least 100%, reduce employee contributions and/or increase other pension benefits.

These remedies use gains to improve the systems' financial strength



The City's Plan: The corridor

Scenario 3: Rising Pension Costs

If City Contribution Rate is between the Corridor Midpoint and Maximum,

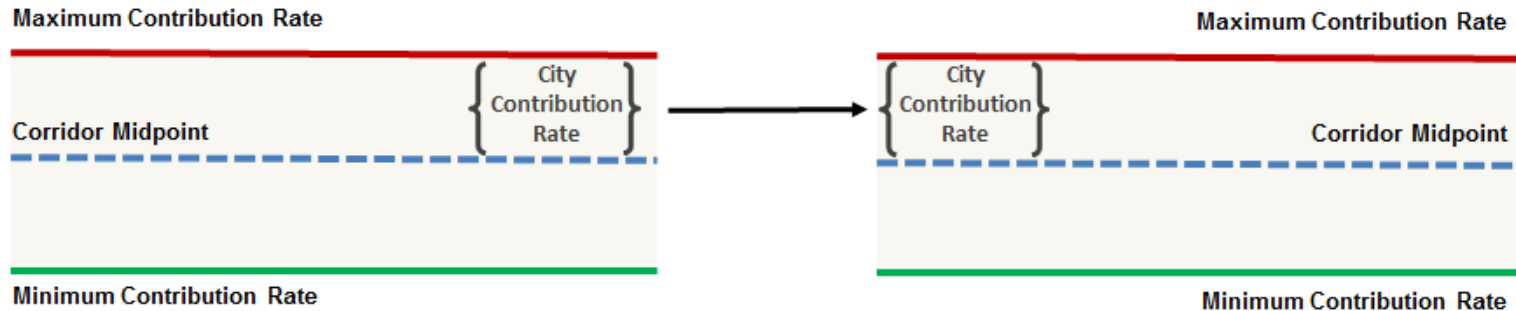

then no adjustments are required and the City pays the City Contribution Rate

- The Corridor Midpoint is what the proposed benefits package is estimated to cost.
- A City Contribution Rate above this amount, up to the Maximum Contribution Rate, represents unexpected costs that the City would absorb

City bears the risk of increasing pension costs up to Maximum Contribution Rate

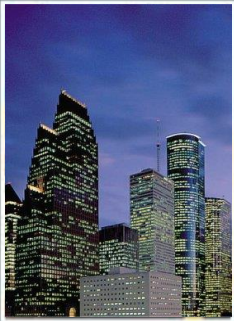

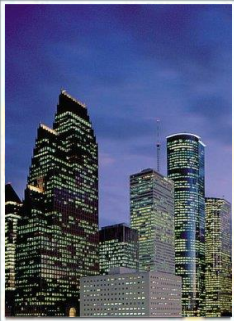

The City's Plan: The corridor

Scenario 4: Rising Pension Costs

If City Contribution Rate is greater than Maximum Contribution Rate,

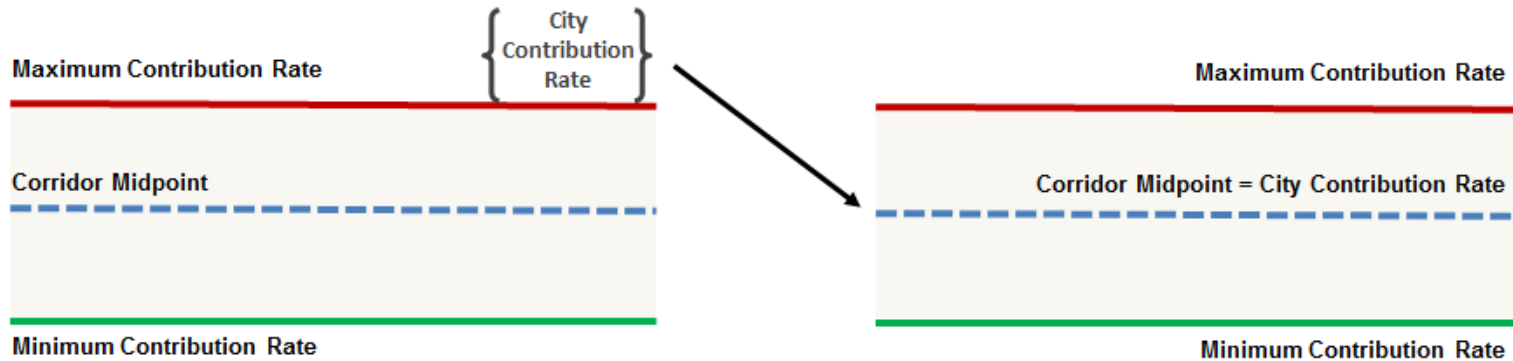

then the City shall take the following actions in listed order to bring the City Contribution Rate back to Corridor Midpoint

1. If previous gains in Scenario 2 resulted in accelerating payoff of the unfunded liability, then re-extend, but to no more than the original 30-year Payoff Year
2. Increase employee contributions and decrease pension benefits to bring the City Contribution Rate back to halfway between the Corridor Midpoint and the Maximum City Contribution Rate
3. If the City Contribution Rate remains above the Corridor Midpoint three years later, then increase employee contributions and decrease pension benefits to bring the City Contribution Rate back to the Corridor Midpoint

These remedies ensure pension costs remain sustainable

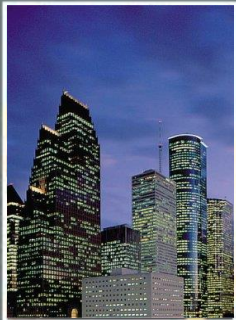

Next steps

- Resolution of support will be presented to Council October 26
 - Administration requests no tag
- State legislation to be filed as soon as possible
 - Earliest opportunity is mid-November



CITY OF HOUSTON - CITY COUNCIL

Meeting Date: 10/25/2016

ALL

Item Creation Date: 10/10/2016

LGL HPOPS 2011 Meet and Confer Amendment

Agenda Item#: 15.

Summary:

ORDINANCE approving and authorizing amendment to Legislature Issues Provision of the 2011 Meet and Confer Agreement between the City of Houston and the **HOUSTON POLICE OFFICERS' PENSION SYSTEM**

Background:

The City Attorney requests that City Council adopt an ordinance approving and authorizing an Amendment to the 2011 Meet and Confer Agreement ("Agreement") between the City and HPOPS.

This Amendment to the Agreement sets forth the Parties' intent to present a mutually agreed pension reform solution to the Texas Legislature in connection with the 85th Legislative Session. In addition, this Amendment obligates the Parties to work together to oppose legislative changes to the mutually agreed pension reform solution when either Party disagrees or opposes such changes. Finally, the Amendment provides that if the legislative changes cannot be resolved to both Parties' satisfaction, then both Parties will no longer support the mutually agreed pension reform solution.

Prior Council Action:

Ordinance No. 2011-460

Contact Information:

Ronald C. Lewis

Phone: (832) 393-6202

ATTACHMENTS:

Description	Type
Signed RCA	Signed Cover sheet

REQUEST FOR COUNCIL ACTION

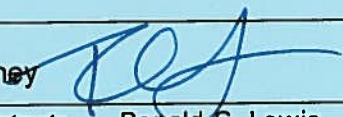
SUBJECT: An ordinance approving and authorizing an Amendment to the Legislature Issues Provision of the 2011 Meet and Confer Agreement between the City of Houston and the Houston Police Officers' Pension System ("HPOPS").		Page 1 of 1	Agenda Item #
FROM (Department or other point of origin): Legal Department		Origination Date 10/19/2016	Agenda Date
DIRECTOR'S SIGNATURE: Ronald C. Lewis, City Attorney 		Council District affected: All	
For additional information contact: Ronald C. Lewis Phone: (832) 393-6202		Date and identification of prior authorizing Council action: Ordinance No. 2011-460	
RECOMMENDATION: (Summary) Adopt an ordinance approving and authorizing an Amendment to the Legislature Issues Provision of the 2011 Meet and Confer Agreement between the City of Houston and HPOPS.			
Amount and Source of Funding: None			
SPECIFIC EXPLANATION: The City Attorney requests that City Council adopt an ordinance approving and authorizing an Amendment to the 2011 Meet and Confer Agreement ("Agreement") between the City and HPOPS. This Amendment to the Agreement sets forth the Parties' intent to present a mutually agreed pension reform solution to the Texas Legislature in connection with the 85th Legislative Session.			
REQUIRED AUTHORIZATION			
Other Authorization:	Other Authorization:	Other Authorization:	



CITY OF HOUSTON - CITY COUNCIL

Meeting Date: 10/25/2016

ALL

Item Creation Date: 10/19/2016

PLN - Ordinance approving amendments to Chapter 41 of the Code of Ordinances

Agenda Item#: 16.

Summary:

ORDINANCE AMENDING CHAPTER 41 OF THE CODE OF ORDINANCES, HOUSTON, TEXAS, relating to street naming; making conforming amendments to other chapters of the Code of Ordinances

Background:

The Planning and Development Department (P&D) recommends the adoption of amendments to Chapter 41 of the Code of Ordinances related to street name changes. These amendments include modifications to the existing citizen-led petition process and establishment of a City-initiated process for street name changes. Specifically, these amendments will do the following:

- Improve the existing citizen-led petition process. These improvements include the following:
 - Elimination of an unnecessary requirement for individual title reports for each property;
 - Focusing petition support on those most affected by the change by requiring petitions be signed by owners of properties that are addressed off the street, rather than by owners of properties abutting the street;
 - Enhancing the community notification and engagement process; and
 - Allowing the broader community to provide input on street name changes, while giving primary consideration to owners of properties that are addressed from the street.
- Establish a limited scope for City-initiated street name change proposals. Under this scope, City-initiated street name changes are allowed under the following circumstances:
 - The change is deemed essential by either the fire chief or the police chief to preserve public health, safety, and welfare; and
 - The street name change directly reflects the name of a public park or public facility that abuts the affected street.
- Clearly define the public process for considering City-initiated street name change proposals; and
- Provide technical updates to improve ordinance administration.

P&D published the draft amendments on Tuesday, August 23, 2016 and opened a 37-day

comment period. The proposed changes were presented to the City Council Quality of Life Committee on August 24th, the Planning Commission on September 1st, and the Super Neighborhood Alliance on September 12th. In addition to these presentations, a pilot project to evaluate the proposed community engagement component of a City-initiated process described in the draft amendments was considered during this timeframe for Dowling Street. As part of the pilot project, P&D held two meetings in the community on September 13th and September 15th to discuss the details of proposed process and roles of P&D, the Planning Commission, and City Council. While the meetings focused primarily on the impact to property owners directly along Dowling Street, residents from the broader community did attend the meetings and provided recommendations on how to improve the community engagement and notification components of the process. This feedback was incorporated into the proposed Chapter 41 amendments. P&D anticipates the renaming of Dowling Street will be offered for City Council consideration in November 2016.

The Planning Commission held a public hearing on September 29, 2016 to receive input on the Chapter 41 changes and consider additional modifications to the draft language based on the community feedback. The Commission voted unanimously to forward the modified changes to City Council for approval.

The Planning and Development Department recommends that City Council approve the ordinance to amend Article II, Division 4 of Chapter 41 of the Code of Ordinances related to street name changes.

Patrick Walsh, P.E.
Director
Planning and Development Department

CC: Andy Icken

Contact Information:

Brian Crimmins - 832-393-6533

ATTACHMENTS:

Description

signed cover sheet

Type

Signed Cover sheet



CITY OF HOUSTON - CITY COUNCIL

Meeting Date:

ALL

Item Creation Date: 10/19/2016

PLN - Ordinance approving amendments to Chapter 41 of the Code of Ordinances

Agenda Item#:

Background:

The Planning and Development Department (P&D) recommends the adoption of amendments to Chapter 41 of the Code of Ordinances related to street name changes. These amendments include modifications to the existing citizen-led petition process and establishment of a City-initiated process for street name changes. Specifically, these amendments will do the following:

- Improve the existing citizen-led petition process. These improvements include the following:
 - Elimination of an unnecessary requirement for individual title reports for each property;
 - Focusing petition support on those most affected by the change by requiring petitions be signed by owners of properties that are addressed off the street, rather than by owners of properties abutting the street;
 - Enhancing the community notification and engagement process; and
 - Allowing the broader community to provide input on street name changes, while giving primary consideration to owners of properties that are addressed from the street.
- Establish a limited scope for City-initiated street name change proposals. Under this scope, City-initiated street name changes are allowed under the following circumstances:
 - The change is deemed essential by either the fire chief or the police chief to preserve public health, safety, and welfare; and
 - The street name change directly reflects the name of a public park or public facility that abuts the affected street.
- Clearly define the public process for considering City-initiated street name change proposals; and
- Provide technical updates to improve ordinance administration.

P&D published the draft amendments on Tuesday, August 23, 2016 and opened a 37-day comment period. The proposed changes were presented to the City Council Quality of Life Committee on August 24th, the Planning Commission on September 1st, and the Super Neighborhood Alliance on September 12th. In addition to these presentations, a pilot project to evaluate the proposed community engagement component of a City-initiated process described in the draft amendments was considered during this timeframe for Dowling Street. As part of the pilot project, P&D held two meetings in the community on September 13th and September 15th to discuss the details of proposed process and roles of P&D, the Planning Commission, and City Council. While the meetings focused primarily on the impact to property owners directly along Dowling Street, residents from the broader community did attend the meetings and provided recommendations on how to improve the community engagement and notification components of the process. This feedback was incorporated into the proposed Chapter 41 amendments. P&D anticipates the renaming of Dowling Street will be offered for City Council consideration in November 2016.

The Planning Commission held a public hearing on September 29, 2016 to receive input on the Chapter 41 changes and consider additional modifications to the draft language based on the community feedback. The Commission voted unanimously to forward the modified changes to City Council for approval.

The Planning and Development Department recommends that City Council approve the ordinance to amend Article II, Division 4 of Chapter 41 of the Code of Ordinances related to street name changes.

Patrick Walsh, P.E.
Director
Planning and Development Department

CC: Andy Icken

Prior Council Action:

N/A

Amount of Funding:

N/A

Contact Information:

Brian Crimmins - 832-393-6533



CITY OF HOUSTON - CITY COUNCIL

Meeting Date: 10/25/2016

ALL

Item Creation Date: 8/19/2016

20RJC03 Amending Chapter 47/Storm Water Discharge

Agenda Item#: 17.

Summary:

ORDINANCE AMENDING ARTICLE XII OF CHAPTER 47 OF THE CODE OF ORDINANCES, HOUSTON, TEXAS, including the repeal of Sections 47-674 and 47-675; relating to Storm Water Discharge; containing findings and other provisions relating to the foregoing subject, providing for severability; declaring an effective date

Background:

SUBJECT: Ordinance updating and amending Chapter 47, Article XII of the city of Houston Code of Ordinances relating to Storm Water Discharge

RECOMMENDATION: (Summary) It is recommended that City Council adopt an ordinance amending Chapter 47, Article XII of the Code of Ordinances relating to Storm Water Discharge to be in compliance with the City's new upcoming Municipal Separate Storm Sewer System (MS4) Permit, adding fees for re-inspection and Storm Water Quality Permit renewal applications.

BACKGROUND: In 1987, Congress amended the Clean Water Act to require National Pollutant Discharge Elimination System (NPDES) permits for discharges from storm sewer systems serving populations over 100,000. In 1990, the Environmental Protection Agency (EPA) issued regulations establishing the permitting process for these permits. The City of Houston, Harris County, Harris County Flood Control District (HCFCD), and the Texas Department of Transportation (TxDOT), collectively known as the Joint Task Force (JTF) were required to obtain a joint National Pollutant Discharge Elimination System (NPDES) Municipal Separate Storm Sewer System (MS4) permit. EPA issued the National Pollutant Discharge Elimination System permit to the JTF effective October 1, 1998. In September 1998 the Texas Natural Resource Conservation Commission (TNRCC), the Texas Commission on Environmental Quality's (TCEQ) predecessor, was authorized by EPA to assume the NPDES program in Texas (renamed the Texas Pollution Discharge Elimination System - TPDES), and on February 24, 2009 the TCEQ issued the existing MS4 permit.

EXPLANATION: The MS4 permit was administratively continued after the renewal application was submitted August 27, 2013 (more than the regulatory required 180 days before the permit expiration of February 24, 2014) and was deemed administrative complete on November 13, 2013. The members of the JTF, minus TxDOT which is separately pursuing an individual state-wide general permit, are currently negotiating with the TCEQ the terms of the new MS4 permit. The proposed changes to Chapter 47, Article XII are necessary to comply with new EPA mandated

requirements in the draft permit, including:

- reducing the size requirement for stormwater quality permits from five acres to one acre,
- changing the classification of Type 1 and Type 2 facilities to be only referred to as “High-risk facilities,”
- clarifying what non-stormwater discharges are allowed to enter the storm sewer system removing the provision for the City to assume the long-term maintenance requirements and liabilities of a structural control specified in a Storm Water Quality Management Plan (SWQMP) of a permitted property, and
- requiring small construction sites under one acre to also perform best management practices to prevent unauthorized stormwater discharges associated with construction activity. allow stormwater inspectors to charge a re-inspection fee, and
- charge a late fee for late submittal of a Storm Water Quality permit renewal application.

None of the requested fee changes impacts the majority of ratepayers. Rather, these are fees for specialized services used by only a small number of customers; currently, the entire rate base is subsidizing services provided to a few customers. This ordinance amendment will bring our code into compliance with the proposed changes to our new MS4 permit.

This item was presented to the Transportation, Technology and Infrastructure Committee meeting on September 19, 2016.

Dale A. Rudick, P.E., Director
Department of Public Works and Engineering

Prior Council Action:

Ord. No. 2001-800, dated 8/29/2001

Contact Information:

J. Timothy Lincoln, P.E. City Engineer

Phone: (832) 394-9140

ATTACHMENTS:

Description

Signed RCA

Building Code Fee Schedule

Type

Signed Cover sheet

Backup Material

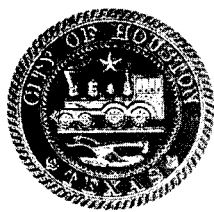

CITY OF HOUSTON - CITY COUNCIL

Meeting Date:

ALL

Item Creation Date: 8/19/2016

20RJ03 Amending Chapter 47, Storm Water Discharge

Agenda Item#:

Background:

SUBJECT: Ordinance updating and amending Chapter 47, Article XII of the city of Houston Code of Ordinances relating to Storm Water Discharge

RECOMMENDATION: (Summary) It is recommended that City Council adopt an ordinance amending Chapter 47, Article XII of the Code of Ordinances relating to Storm Water Discharge to be in compliance with the City's new upcoming Municipal Separate Storm Sewer System (MS4) Permit, adding fees for re-inspection and Storm Water Quality Permit renewal applications.

BACKGROUND: In 1987, Congress amended the Clean Water Act to require National Pollutant Discharge Elimination System (NPDES) permits for discharges from storm sewer systems serving populations over 100,000. In 1990, the Environmental Protection Agency (EPA) issued regulations establishing the permitting process for these permits. The City of Houston, Harris County, Harris County Flood Control District (HCFCD), and the Texas Department of Transportation (TxDOT), collectively known as the Joint Task Force (JTF) were required to obtain a joint National Pollutant Discharge Elimination System (NPDES) Municipal Separate Storm Sewer System (MS4) permit. EPA issued the National Pollutant Discharge Elimination System permit to the JTF effective October 1, 1998. In September 1998 the Texas Natural Resource Conservation Commission (TNRCC), the Texas Commission on Environmental Quality's (TCEQ) predecessor, was authorized by EPA to assume the NPDES program in Texas (renamed the Texas Pollution Discharge Elimination System - TPDES), and on February 24, 2009 the TCEQ issued the existing MS4 permit.

EXPLANATION: The MS4 permit was administratively continued after the renewal application was submitted August 27, 2013 (more than the regulatory required 180 days before the permit expiration of February 24, 2014) and was deemed administrative complete on November 13, 2013. The members of the JTF, minus TxDOT which is separately pursuing an individual state-wide general permit, are currently negotiating with the TCEQ the terms of the new MS4 permit. The proposed changes to Chapter 47, Article XII are necessary to:

- comply with new EPA mandated requirements in the draft permit, including:
 - o reducing the size requirement for stormwater quality permits from five acres to one acre,
 - o changing the classification of Type 1 and Type 2 facilities to be only referred to as "High-risk facilities,"
 - o clarifying what non-stormwater discharges are allowed to enter the storm sewer system
- removing the provision for the City to assume the long-term maintenance requirements and liabilities of a structural control specified in a Storm Water Quality Management Plan (SWQMP) of a permitted property, and
- requiring small construction sites under one acre to also perform best management practices to prevent unauthorized stormwater discharges associated with construction activity.
 - allow stormwater inspectors to charge a re-inspection fee, and
 - charge a late fee for late submittal of a Storm Water Quality permit renewal application.

None of the requested fee changes impacts the majority of ratepayers. Rather, these are fees for specialized services used by only a small number of customers; currently, the entire rate base is subsidizing services provided to a few customers. This ordinance amendment will bring our code into compliance with the proposed changes to our new MS4 permit.

This item was presented to the Transportation, Technology and Infrastructure Committee meeting on September 19, 2016.

A handwritten signature in black ink, reading "Dale A. Rudick".

Dale A. Rudick, P.E., Director
Department of Public Works and Engineering

Prior Council Action:

Ord. No. 2001-800, dated 8/29/2001

Contact Information:

J. Timothy Lincoln, P.E. City Engineer

Phone: (832) 394-9140

ATTACHMENTS:

Description

Prior Council Action

Type

Backup Material



2016 BUILDING CODE ENFORCEMENT PERMIT FEE SCHEDULE



NOTE: ALL PERMIT FEES ARE SUBJECT TO THE MINIMUM AND ADMINISTRATIVE FEES.

VALUATION TABLE

Use this table to determine fees when noted in the fee schedule

Valuation (rounded to the nearest dollar)	Permit Fee (NOTE: The minimum permit fee is \$75.05)
\$0.01 - \$7,000	\$ 38.74
\$7,001 - \$150,000	\$ 38.74 for the first \$7,000 plus \$4.42 for every additional \$1000 in valuation or fraction thereof
\$150,001 - \$200,000	\$671.83 for the first \$150,000 plus \$4.15 for every additional \$1000 in valuation or fraction thereof
\$200,001 - \$300,000	\$879.36 for the first \$200,000 plus \$3.87 for every additional \$1000 in valuation or fraction thereof
\$300,001 - \$500,000	\$1,266.74 for the first \$300,000 plus \$3.59 for every additional \$1000 in valuation or fraction thereof
\$500,001 - \$1,000,000	\$1,986.18 for the first \$500,000 plus \$3.31 for every additional \$1000 in valuation or fraction thereof
\$1,000,001 - \$5,000,000	\$3,646.40 for the first \$1,000,000 plus \$ 3.03 for every additional \$1000 in valuation or fraction thereof
\$5,000,001 to \$50,000,000	\$15,821.35 for the first \$5,000,000 Plus \$1.65 for every additional \$1,000 in valuation or fraction thereof
\$50,000,001 and up	\$90,531.32 for the first \$50,000,000 Plus \$1.10 for every additional \$1,000 in valuation or fraction thereof

ADMINISTRATIVE & GENERAL INSPECTION FEES

Description	Fee
Administrative fee	\$ 27.66
Minimum permit fee	\$ 75.05
Certificate of Occupancy	\$ 77.48
Temporary Certificate of Occupancy	\$ 77.48
Reinspection fee	\$ 77.48
Special requested inspections	\$265.63
Emergency inspections	\$166.02 - Min. 4 hours \$38.74 - Ea. hour or portion thereof exceeding 4 hours
Inspections outside of jurisdiction	\$265.63 + the current standard mileage rate as published by the IRS.
Overtime inspections/plan reviews	\$265.63- Min. 4 hours \$69.17 - Ea. hour or portion thereof exceeding 4 hours
Name change	\$ 77.48
Address change	\$ 77.48
Duplicate job card	\$ 77.48
Investigation Fee (Unpermitted Construction – per occurrence)	\$274.82 Min. (or double fee whichever is greater) This fee is in addition to the permit fee.
Request for special approval, alternate method, interpretation or modification due to practical difficulty.	\$ 44.27 - Standard Request \$110.68 - Moderate Request \$553.41, plus \$138.34 each hour or fraction thereof exceeding 4 hours - Extensive Requests

The building permit fee for remodels, alterations, and new structures is determined by **valuation**. **Valuation** is the total cost of construction to the end user, excluding the land purchase costs and the overhead attributed to the land purchase. The value of donated goods and services is included.

Notes:

- New single family homes with a valuation of \$115,000 or less shall receive a 50 percent discount on permit fees.
- A historic building that has been designated by the jurisdiction as a landmark or that is located within a historic district designated by the jurisdiction, or for which designation as a landmark or part of a historic district is pending, shall receive a 50 percent discount on permit fees provided that a certificate of appropriateness issued pursuant to Chapter 33 of the City Code is submitted with the construction documents.

PLAN REVIEW FEES

Description	Fee
Prefabricated buildings or modular buildings	See Valuation Table
Residential Master Plans	\$ 77.48
Deferred submittals, revisions	\$ 77.48 or 15% of the permit fee, whichever is greater
Paving plan review for paving at a single family dwelling, not associated with another project	\$ 77.48

PARKING LOTS, PAVED AREAS & SIDEWALKS

Description	Fee
Parking lot or paved areas	\$ 77.48- First 1,000 sq. ft. or part thereof \$ 2.77- Each additional 1,000 sq. ft or part thereof
Sidewalks	\$ 38.74 -First 100 lineal ft \$ 9.40 -Each additional 100 lineal ft
Driveways	\$ 38.74
Culvert pipes (not in driveways)	\$ 38.74 -First 100 lineal ft \$ 9.40 -Each additional 100 lineal ft
Curb and Gutter	\$ 38.74 -First 100 lineal ft \$ 9.40-Each additional 100 lineal ft

FENCES

Description	Fee
First 100 lineal feet or part thereof	\$ 60.87
Each additional 100 lineal feet or part thereof	\$ 9.40

STRUCTURAL PERMIT FEES	
Description	Fee
New buildings	See valuation table
Additions, alterations, remodels, conversions, and repairs	See valuation table
Demolition of a building	\$ 77.48 - For the first story; \$ 38.74 - For each additional story
Towers (other than signs)	See valuation table
Prefabricated fireplaces	\$ 16.60
Sand or water blasting	\$ 38.74
Grading	\$ 77.48
Loading docks	\$ 38.74 - First 100 lineal feet; \$ 0.09 - Each additional lineal ft.
Paint spray booth	\$ 38.74
Barricades	\$ 60.87 - First 100 lineal feet \$ 16.60 - Each additional 100 lineal foot
Fire Escapes	\$ 33.19 - Four stories or less \$ 16.60 - Each additional story in height

OCCUPANCY & INSPECTION FEES	
Description	Fee
Certificate of Occupancy or Life Safety Inspection	\$442.73 - First story; \$110.68 - Each additional story
Certificate of Occupancy or Life Safety Inspection	.01, Each additional sq. ft. above 10,000 sq. ft. with a maximum of 200,000 sq. ft
Certificate of Occupancy or Life Safety Inspection (Residential multifamily buildings, per contiguous project)	\$442.73 - 1-30 units; \$ 11.06 - Each additional unit
Duplicate Life Safety Compliance Certificate	\$ 77.48
Certificate name change only	\$ 77.48
Change of address	\$ 77.48
Certificate for individual retail or office spaces of less than 3,000 sq. ft. in multi-tenant buildings	\$ 77.48 (If performed at the same time as the building core inspection)
Certificate for individual retail or office spaces of less than 3,000 sq. ft. in multi-tenant buildings	\$221.36
Incinerator inspection	\$ 77.48
Revalidation inspection	\$ 77.48

HVAC FEES	
Description	Fee
Minimum Fee	\$ 75.05
Ventilating systems or heat only systems (other than boilers)	2.0 percent of valuation, plus \$ 38.74
Repairs or alterations to existing HVAC or refrigeration systems	2.0 percent of valuation, plus \$ 38.74 Except: Ducts and grilles in a lease space, where total valuation is less than \$500.00: \$38.74 for each lease space.
Air-handling and duct systems for air-conditioning in buildings that have heating or cooling fluid from an external source	\$ 4.97 per ton, plus \$ 38.74
Air-conditioning cooling equipment located in a building other than the one being cooled	\$ 4.97 per ton, plus \$ 38.74

HVAC FEES (continues)	
Description	Fee
A complete air-conditioning system where the cooling equipment, the air-handling equipment and duct system are in the same building.	\$ 9.40 per ton, plus \$ 38.74
Commercial, manufacturing and industrial process refrigeration systems	\$ 9.40 per ton, plus \$ 38.74
Temporary operation inspection	\$ 38.74
Local vent	\$ 77.48
Self-contained air conditioning units	\$ 9.40 per ton, plus \$ 38.74
Boiler installation based on Btu input and/or HP	\$ 38.74 plus, \$ 4.42 per BHP or part thereof
Boiler Repair permit	2.0 percent of valuation, plus \$ 38.74
Manufactured home inspections	\$ 77.48
Certificate of approval	\$ 22.13
Annual Boiler Fee	\$ 55.34

PLUMBING FEES	
Description	Fee
Minimum Permit Fee	\$ 80.41
Temporary gas inspection	\$ 75.05
Gas permit and inspection	\$ 37.53 - Up to 4 openings \$ 6.43 - Ea. additional opening
Manufactured home inspection	\$ 75.05
Standpipe system	\$ 80.41-1-25 hose connections \$ 3.75 Ea. additional connection
Irrigation System, per head	\$ 1.61 - 1 to 200 heads \$ 1.07- Each additional head
Furnace (nonduct type)	\$ 28.22- First furnace \$ 9.40- Each additional furnace
Floor furnace (nonduct type)	\$ 38.74
Infrared heaters	\$ 28.22- One or two \$ 9.40- Each additional
Yard lights or barbecue grills	\$ 28.22- First opening \$ 9.40- Each additional opening
Wall heater	\$ 28.22 - First heater \$ 9.40- Each additional heater
Gas steam radiator	\$ 38.74 - One \$ 9.40- Each additional
Commercial dryer	\$ 38.74
Commercial oven	\$ 44.27
Plumbing fixtures	\$ 28.22- One to three \$ 9.40- Each additional
Warm-air circulators (nonduct)	\$ 38.74- First three \$ 9.40- Each additional
Tie to curb inlet-storm sewer	\$ 71.93
Manholes, each	\$ 71.93
Roof drain or outside downspout connection to drainage system	\$ 28.22- One or two \$ 9.40- Each additional
Catch basin or outside area drain	\$ 28.22- One or two \$ 9.40- Each additional

PLUMBING FEES (continues)	
Description	Fee
Sewer connections	\$ 44.27
Ground in plumbing for shell buildings 3,000 sq. ft. or less floor area	\$ 38.74
Each additional 1,000 sq. ft. or part thereof	\$ 17.70
Disconnect and plug main sewer connection	\$ 77.48
Tanks (not septic tanks) 0-1,000 gallons	\$ 77.48
1,001-6,000 gallons	\$ 94.07
6,001-15,000 gallons	\$116.21
15,001-30,000 gallons	\$166.02
Over 30,000 gallons	\$188.16
Medical gas	\$ 33.19 – First 10 openings \$ 5.53 – Each additional

ELECTRICAL FEES	
Description	Fee
Minimum Permit Fee	\$ 75.05
Meter Loop and Service Up to and including 50kW	\$ 77.48
MLS 51kW – 250kW	\$ 83.01
MLS Over 250kW	\$ 88.54
Panels with eight or more circuits, each	\$ 7.74
Outlets, each	\$ 1.10
Fixtures, each	\$ 1.10
Range receptacle	\$ 3.87
Clothes dryer	\$ 3.87
Stove top	\$ 3.87
Oven	\$ 3.87
Garbage disposal	\$ 3.87
Dishwasher	\$ 3.87
Window air conditioner receptacle	\$ 3.87
Motors Up to and including 1 HP	\$ 3.31
Motors 1 HP through 10 HP	\$ 9.40
Motors over 10 HP	\$ 6.64
Over 10 HP (each additional HP over 10)	\$ 1.49
Heaters/Generators Up to and including 1 kW	\$ 3.31
Heater/ Generators 1 – 10 kW	\$ 9.40
Heaters/Generators over 10 kW	\$ 6.64
Total kW over 10 kW (each additional kW over 10 kW)	\$ 1.49
Transformers Up to and including 1KVA	\$ 3.31
Transformers 1 through 10 KVA	\$ 9.40
Transformers over 10 KVA	\$ 6.64
Total KVA over 10 KVA (each additional KVA over 10 KVA)	\$ 1.49
Shop inspection of incandescent electrical signs and gas or vacuum tube signs, 0-5 kVA	\$ 38.74
Each additional kVA or fraction thereof exceeding 5 kVA	\$ 8.85
Installation inspection of incandescent electrical signs and gas or vacuum tube signs, 0-5 kVA	\$ 38.74
Each additional kVA or fraction thereof exceeding 5 kVA	\$ 8.85
Streamers and festoon lighting per circuit, each	\$ 9.40
Ball park and parking lot light poles	\$ 77.48 -First pole \$ 38.74- Ea. additional pole
Temporary saw poles	\$ 77.48
Temporary cut-in made permanent	\$ 77.48

ELECTRICAL FEES (continues)	
Description	Fee
Temp. Installations (Saws, spray machines, etc)	\$ 28.22
Temp. Sound equipment	\$ 33.19
Temp. Lighting installations	\$ 28.22
Reconnection fee	\$ 77.48
Electrical Vehicle Charging Outlet, Level 1	\$ 77.48
Electrical Vehicle Charging Outlet, Level 2	\$ 83.01
Electrical Vehicle Charging Outlet, Level 3	\$ 88.54
NOTE: Plans required for Level 3	

ELEVATOR FEES	
Description	Fee
Minimum Permit Fee	\$ 75.05
Installation of Elevator, Escalator, Manlift, Moving Walk, Inclined Stairway, Chairlift, Personnel Hoist or Wheelchair Lift Permit Base Charge for up to \$40,000 in value, each (not in private residence)	\$ 77.48
Installation of Elevator, Escalator, Manlift, Moving Walk, Inclined Stairway, Chairlift, Personnel Hoist or Wheelchair Lift Permit Base Charge for up to \$40,000 in value Base Fee plus Fee for each additional \$1,000 valuation or fraction thereof over \$40K \$40,000 (not in private residence)	\$ 2.21
Personnel Hoist Manufacturing Design (not in private residence)	\$553.41
Installation in private residence of Elevator, Escalator, Manlift, Moving Walk, Inclined Stairway, Chairlift, Personnel Hoist or Wheelchair Lift - Permit Base Charge for up to \$10,000 of valuation, each	\$ 28.22
Installations in private residence of Elevator, Escalator, Manlift, Moving Walk, Inclined Stairway, Chairlift, Personnel Hoist or Wheelchair Lift Permit Base Charge for up to \$10,000 in value plus Fee for each additional \$1,000 in valuation or fraction thereof over the first \$10,000	\$ 2.21

FIRE PROTECTION/ALARM FEES	
Description	Fee
Alarms, detectors, central section security testing:	
0-10 devices	\$ 75.05
11-25 devices	\$107.22
26-200 devices	\$160.83
Each additional device after the first 200	\$ 2.68
Electronic Locks:	
Minimum Permit Fee	\$ 75.05
First 2 floors	\$ 53.61
Each additional floor after the first 2 floors	\$ 16.08
Fire sprinkler system (any head or group of heads up to 25 that is regulated with a valve for any portion of a building)	\$ 80.41
Each additional head	\$ 3.75
Fire sprinkler system plan review, per head	\$ 1.88

HABITABILITY INSPECTION FEES	
Description	Fee
Multi-Family Rental Building (MFRB) Inspection	
Minimum Fee	\$110.68
Per Unit	\$ 4.42



CITY OF HOUSTON - CITY COUNCIL

Meeting Date: 10/25/2016

ALL

Item Creation Date: 10/3/2016

20SWB14 Amend City of Houston Commercial Energy
Code

Agenda Item#: 18.

Summary:

ORDINANCE amending the City of Houston Construction Code by adopting a revised Commercial Energy Conservation Code based on the 2015 International Energy Conservation Code—Commercial Provisions and the American Society of Heating, Refrigeration and Air Conditioning Engineers Standard 90.1-2013; containing findings and other provisions relating to the foregoing subject; containing a repealer; containing a savings clause; providing an effective date; providing for severability

Background:

RECOMMENDATION:

Approve an ordinance to adopt an updated City of Houston Commercial Energy Code, including local administrative provisions, to coordinate with local ordinances and construction practices, conform with Texas state law, and comply with the minimum provisions and adopted regulations established by the Texas State Energy Conservation Office.

SPECIFIC EXPLANATION:

The City of Houston Commercial Energy Code is updated periodically to adopt newer versions of nationally promulgated codes which are then amended to meet local standards. As published in the January 1, 2016 edition of the Texas Register, the State Energy Conservation Office (SECO) amended 34 Texas Administrative Code §19.53 to establish the 2015 *International Energy Conservation Code* (IECC) as the energy code for commercial construction, effective November 1, 2016. Accordingly, all local jurisdictions must comply with the new energy code by November 1, 2016. A 30 day period will be allowed for the codes to take effect after adoption by City Council in order to provide ample time for industry to prepare. State law requires at least a minimum of 30 days prior to enactment. Timely adoption of this code is further recommended because the City is under review from the Insurance Services Office which will provide a grade pursuant to the Building Code Effectiveness Grading Schedule based on current codes among other items. This grading schedule affects the City's insurance rates with regard to how well the City can mitigate against natural hazards. The Houston Fire Department and the City's participation in the National Flood Insurance Program are also affected by this grading schedule.

The IECC is published by the International Code Council. The IECC is the nationally recognized energy code adopted in most U.S. jurisdictions. The IECC regulates energy efficiency for commercial construction, along with the administrative provisions for enforcement.

ASHRAE 90.1 is a U.S. standard that provides minimum requirements for energy efficient designs

for buildings except for low-rise residential buildings. The proposed local amendments to these codes would set up certain administrative policies and procedures as well as modify other base code principles to be more applicable to the health, safety and welfare of the citizens of Houston. The proposed amendments were reviewed and recommended by the Energy Committee of the Construction Industry Council during a series of meetings, and the amendments were posted on the City of Houston website for public comment.

This item was presented at the Transportation, Technology, and Infrastructure Committee meeting on October 17, 2016.

Dale A. Rudick, P.E., Director
Department of Public Works and Engineering

Contact Information:

Mark L. Loethen, P. E., CFM
Deputy Director
Phone: (832) 395-2705

ATTACHMENTS:

Description

Signed Coversheet

Type

Signed Cover sheet



CITY OF HOUSTON - CITY COUNCIL

Meeting Date:

ALL

Item Creation Date: 10/3/2016

20SWB14 Amend City of Houston Commercial Energy Code

Agenda Item#:

Background:

RECOMMENDATION:

Approve an ordinance to adopt an updated City of Houston Commercial Energy Code, including local administrative provisions, to coordinate with local ordinances and construction practices, conform with Texas state law, and comply with the minimum provisions and adopted regulations established by the Texas State Energy Conservation Office.

SPECIFIC EXPLANATION:

The City of Houston Commercial Energy Code is updated periodically to adopt newer versions of nationally promulgated codes which are then amended to meet local standards. As published in the January 1, 2016 edition of the Texas Register, the State Energy Conservation Office (SECO) amended 34 Texas Administrative Code §19.53 to establish the 2015 *International Energy Conservation Code* (IECC) as the energy code for commercial construction, effective November 1, 2016. Accordingly, all local jurisdictions must comply with the new energy code by November 1, 2016. A 30 day period will be allowed for the codes to take effect after adoption by City Council in order to provide ample time for industry to prepare. State law requires at least a minimum of 30 days prior to enactment. Timely adoption of this code is further recommended because the City is under review from the Insurance Services Office which will provide a grade pursuant to the Building Code Effectiveness Grading Schedule based on current codes among other items. This grading schedule affects the City's insurance rates with regard to how well the City can mitigate against natural hazards. The Houston Fire Department and the City's participation in the National Flood Insurance Program are also affected by this grading schedule.

The IECC is published by the International Code Council. The IECC is the nationally recognized energy code adopted in most U.S. jurisdictions. The IECC regulates energy efficiency for commercial construction, along with the administrative provisions for enforcement.

ASHRAE 90.1 is a U.S. standard that provides minimum requirements for energy efficient designs for buildings except for low-rise residential buildings. The proposed local amendments to these codes would set up certain administrative policies and procedures as well as modify other base code principles to be more applicable to the health, safety and welfare of the citizens of Houston.

The proposed amendments were reviewed and recommended by the Energy Committee of the Construction Industry Council during a series of meetings, and the amendments were posted on the City of Houston website for public comment.

This item was presented at the Transportation, Technology, and Infrastructure Committee meeting on October 17, 2016.

Dale A. Rudick, P.E., Director
Department of Public Works and Engineering

Contact Information:

Mark L. Loethen, P. E., CFM

Deputy Director

Phone: (832) 395-2705

ATTACHMENTS:

Description	Type
<u>Ordinance Commercial Energy Code</u>	Ordinance/Resolution/Motion
<u>Amendments to the 2015 IECC Commercial Energy Code</u>	Other



CITY OF HOUSTON - CITY COUNCIL

Meeting Date: 10/25/2016

District A

Item Creation Date: 6/28/2016

20BAM59A/Abandonment and sale of Castlebay
Street/SY15-133

Agenda Item#: 19.

Summary:

ORDINANCE finding and determining that public convenience and necessity no longer require the continued use of Castlebay Street, from the east right-of-way line of Burr Oak Street east to the east property line of the remaining portion of Lot 13, Block 6 and a 10 foot-wide prescriptive water line easement, in the former Belmore Street, from the south right-of-way line west Tidwell Road south 35 feet, located in the Rosslyn Subdivision, out of the Joseph Bays Survey, A-127, Houston, Texas; vacating and abandoning the street to Contempo Builder LLC, abutting owner, in consideration of the payment of \$173,580.00 to the City and other consideration - **DISTRICT A - STARDIG**

Background:

SUBJECT: Ordinance authorizing the abandonment and sale of Castlebay Street, from the east right-of-way line of Burr Oak Street east to the east property line of the remaining portion of Lot 13, Block 6 and a 10 foot-wide prescriptive water line easement, in former Belmore Street, from the south right-of-way line of West Tidwell Road south 35 feet, located in the Rosslyn Addition, out of the Joseph Bays Survey. **Parcels SY15-133A and SY15-133B**

RECOMMENDATION: (Summary) It is recommended City Council approve an ordinance authorizing the abandonment and sale of Castlebay Street, from the east right-of-way line of Burr Oak Street east to the east property line of the remaining portion of Lot 13, Block 6 and a 10 foot-wide prescriptive water line easement, in former Belmore Street, from the south right-of-way line of West Tidwell Road south 35 feet, located in the Rosslyn Addition, out of the Joseph Bays Survey. **Parcels SY15-133A and SY15-133B**

SPECIFIC EXPLANATION: Mary Lou Henry, Vernon G. Henry & Associates, 3050 Post Oak Boulevard, Suite 450, Houston, Texas 77056, on behalf of Contempo Builder LLC, (David Borhorquez, President), requested the non-acceptance of Castlebay Street, from the east right-of-way line of Burr Oak Street east to the east property line of the remaining portion of Lot 13, Block 6 and Belmore Street from, the south right-of-way line of West Tidwell Road south to the north right-of-way line of Castlebay Street and Belmore Street from, the south right-of-way line of Castlebay Street south to the north right-of-way line of Highrock Street, all located within the Rosslyn Addition, out of the Joseph Bays Survey. Since Castlebay Street was used for utility purposes the Joint Referral Committee approved the request as an abandonment and sale. Contempo Builder LLC, the applicant, plans to replat this portion of Castlebay Street with its abutting property to create one

new reserve for construction of a single family residential development. The applicant also requested the non-acceptance of Belmore Street from, the south right-of-way line of West Tidwell Road south to the north right-of-way line of Castlebay Street and Belmore Street from, the south right-of-way line of Castlebay Street south to the north right-of-way line of Highrock Street (Parcels SY16-006A and SY16-006B) associated with this transaction that will be completed by a separate process. The Joint Referral Committee reviewed and approved this request.

Contempo Builder LLC has complied with the transaction requirements, has accepted the City's offer, and has rendered payment in full.

The City will sell to Contempo Builder LLC:

Parcel SY15-133A	
34,541 square-foot street easement:	\$172,705.00
Valued at \$5.00 PSF	
Parcel SY15-133A	
350 square-foot prescriptive water line easement:	\$ 875.00
Valued at \$2.50 PSF	
TOTAL ABANDONMENT AND SALE	\$173,580.00

Therefore, it is recommended City Council approve an Ordinance authorizing the abandonment and sale of Castlebay Street, from the east right-of-way line of Burr Oak Street east to the east property line of the remaining portion of Lot 13, Block 6 and a 10-foot-wide prescriptive water line easement, in former Belmore Street, from the south right-of-way line of West Tidwell Road south 35 feet, located in the Rosslyn Addition, out of the Joseph Bays Survey.

Contact Information:

Nancy P. Collins
 Senior Assistant Director-Real Estate
 (832) 395-3130

Dale A. Rudick, P.E., Director
Department of Public Works and Engineering

ATTACHMENTS:

Description	Type
Signed RCA	Signed Cover sheet

Parcel Map

Backup Material

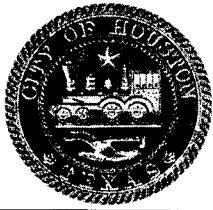

CITY OF HOUSTON - CITY COUNCIL

Meeting Date:

District A

Item Creation Date: 6/28/2016

20BAM59A/Abandonment and sale of Castlebay Street/SY15-133

Agenda Item#:

Background:

SUBJECT: Ordinance authorizing the abandonment and sale of Castlebay Street, from the east right-of-way line of Burr Oak Street east to the east property line of the remaining portion of Lot 13, Block 6 and a 10 foot-wide prescriptive water line easement, in former Belmore Street, from the south right-of-way line of West Tidwell Road south 35 feet, located in the Rosslyn Addition, out of the Joseph Bays Survey. **Parcels SY15-133A and SY15-133B**

RECOMMENDATION: (Summary) It is recommended City Council approve an ordinance authorizing the abandonment and sale of Castlebay Street, from the east right-of-way line of Burr Oak Street east to the east property line of the remaining portion of Lot 13, Block 6 and a 10 foot-wide prescriptive water line easement, in former Belmore Street, from the south right-of-way line of West Tidwell Road south 35 feet, located in the Rosslyn Addition, out of the Joseph Bays Survey. **Parcels SY15-133A and SY15-133B**

SPECIFIC EXPLANATION: Mary Lou Henry, Vernon G. Henry & Associates, 3050 Post Oak Boulevard, Suite 450, Houston, Texas 77056, on behalf of Contempo Builder LLC, (David Borhorquez, President), requested the non-acceptance of Castlebay Street, from the east right-of-way line of Burr Oak Street east to the east property line of the remaining portion of Lot 13, Block 6 and Belmore Street from, the south right-of-way line of West Tidwell Road south to the north right-of-way line of Castlebay Street and Belmore Street from, the south right-of-way line of Castlebay Street south to the north right-of-way line of Highrock Street, all located within the Rosslyn Addition, out of the Joseph Bays Survey. Since Castlebay Street was used for utility purposes the Joint Referral Committee approved the request as an abandonment and sale. Contempo Builder LLC, the applicant, plans to replat this portion of Castlebay Street with its abutting property to create one new reserve for construction of a single family residential development. The applicant also requested the non-acceptance of Belmore Street from, the south right-of-way line of West Tidwell Road south to the north right-of-way line of Castlebay Street and Belmore Street from, the south right-of-way line of Castlebay Street south to the north right-of-way line of Highrock Street (Parcels SY16-006A and SY16-006B) associated with this transaction that will be completed by a separate process. The Joint Referral Committee reviewed and approved this request.

Contempo Builder LLC has complied with the transaction requirements, has accepted the City's offer, and has rendered payment in full.

The City will sell to Contempo Builder LLC:

Parcel SY15-133A	
34,541 square-foot street easement:	\$172,705.00
Valued at \$5.00 PSF	
Parcel SY15-133A	
350 square-foot prescriptive water line easement:	\$ 875.00
Valued at \$2.50 PSF	
TOTAL ABANDONMENT AND SALE	\$173,580.00

Therefore, it is recommended City Council approve an Ordinance authorizing the abandonment and sale of Castlebay Street, from the east right-of-way line of Burr Oak Street east to the east property line of the remaining portion of Lot 13, Block 6 and a 10-foot-wide prescriptive water line easement, in former Belmore Street, from the south right-of-way line of West Tidwell Road south 35 feet, located in the Rosslyn Addition, out of the Joseph Bays Survey.

Contact Information:

Nancy P. Collins
Senior Assistant Director-Real Estate
(832) 395-3130



Dale A. Rudick, P.E., Director
Department of Public Works and Engineering

ATTACHMENTS:

Description

Parcel Map

Type

Backup Material

PARCEL MAP

Abandonment and sale of Castlebay Street, from the east right-of-way line of Burr Oak Street east to the east property line of the remainder of Lot 13, Block 6 and a 10-foot-wide prescriptive water line easement in the location of Belmore Street, from the south right-of-way line of West Tidwell Road south 35 feet, located within the Rosslyn Addition, out of the Joseph Bays Survey. Parcels SY15-133A and SY15-133B

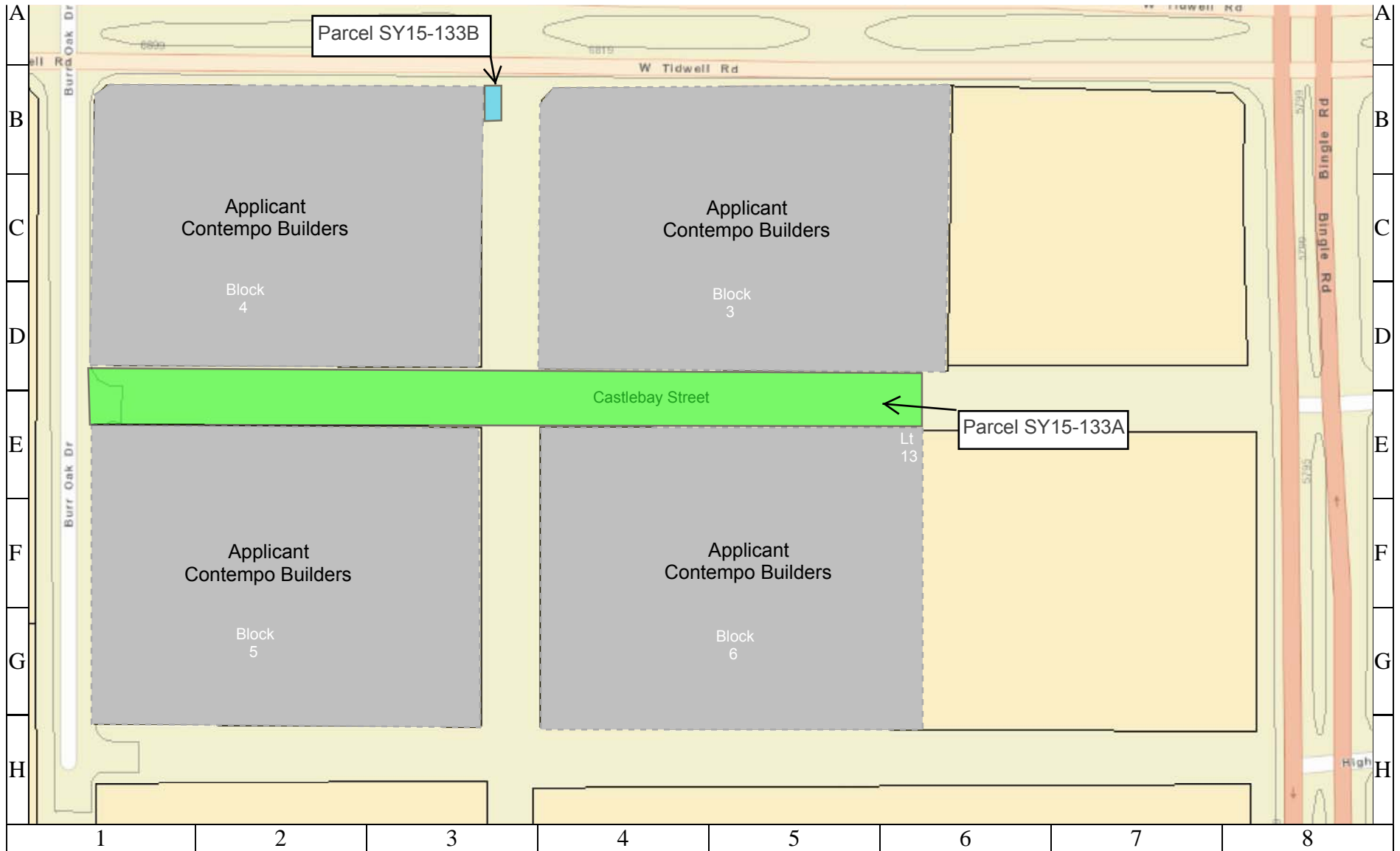

CITY OF HOUSTON
Department of Public Works and Engineering
Geographic Information & Management System (GIMS)

DISCLAIMER: THIS MAP REPRESENTS THE BEST INFORMATION AVAILABLE TO THE CITY.
 THE CITY DOES NOT WARRANT ITS ACCURACY OR COMPLETENESS.
 FIELD VERIFICATIONS SHOULD BE DONE AS NECESSARY.



 Applicant - Contempo Builder



CITY OF HOUSTON - CITY COUNCIL

Meeting Date: 10/25/2016

ALL

Item Creation Date: 10/4/2016

HHD - HIV Prevention

Agenda Item#: 20.

Summary:

ORDINANCE approving and authorizing the Director of the City of Houston Health Department to accept continuation grant funds from the U.S. Department of Health and Human Services, Centers for Disease Control and Prevention, for the City's HIV Prevention Activities; declaring the City's eligibility for such grant; authorizing the Director to expend the grant funds, as awarded, and to apply for and accept all subsequent awards, if any, pertaining to the grant

Background:

The Houston Health Department (HHD) requests City Council approval of an ordinance authorizing the extension of the project period for a grant application to the United States Department of Health and Human Services, Centers for Disease Control (CDC) for the City's HIV Prevention Activities Reducing HIV Infections and Improve Engagement in HIV Medical Care among Men Who Have Sex With Men (MSM) and Transgender Persons (TG). The budget period is 9/30/2016 through 9/29/2017. The project period is 9/30/2015 through 9/29/2018.

HHD also requests City Council to authorized the Director or his designee to act as the City's representative in the application process with the authority to apply for, accept and expend the grant funds, as awarded, and to apply for and accept and expend all subsequent awards, to extend the budget and/or the project period and authorize the Mayor to execute all related contracts, agreements and documents with the approval of the City Attorney in connection with the grant not to exceed five years.

This project focuses on MSM and transgender people at high risk for HIV infection, particularly people of color. Funding from this grant will allow HHD to implement Pre-exposure prophylaxis (PrEP) activities. PrEP is a combination of two HIV medicines approved for daily use to help prevent an HIV-negative person from getting HIV from a HIV positive sexual or injection-drug-using partner. PrEP activities include:

1. Collecting community baseline level of PrEP awareness and interest among target population by surveying 200 MSM and TG
2. Developing at least one (1) comprehensive tracking process to capture when HIV staff offer PrEP education and refer clients for services, particularly MSM and TG.
3. Increasing media buys and support to prescribe PrEP through awareness building and training opportunities.
4. Implementing at least two (2) PrEP referral protocols for HHD to encourage PrEP uptake.

5. Conducting at least three (3) key informant interviews with known PrEP providers about their best practices for Texas-specific reimbursement and billing strategies to integrate into provider technical assistance and provider resources.

This funding opportunity will also allow HHD to use Data to Care, a new public health strategy that uses HIV surveillance data to identify HIV-diagnosed individuals not in care, link them to care, and support the HIV Care Continuum. Using Data to Care to achieve a population-based surveillance estimate of HIV among transgender Houstonians, HHD will:

1. Increase partnerships by 8% for data to care interventions with the 38 documented HIV care providers in Houston.
2. Increase referrals to linkage programs by 25% utilizing the Maven data systems when streamlining referrals.
3. Create new Houston – specific presentations to provide education awareness on the importance of engagement and retention in HIV care to targeted population, specifically, MSM and TG persons.
4. Generate Data-to-Care list identifying 29 TG persons with previous evidence of HIV care.
5. Conduct at least five (5) presentations on HIV care retention and cultural sensitivity at local and national HIV conferences.

Grant funding allows \$1,342,281.00 in personnel costs (20 FTEs) and \$ 2,622,177.00 in program expenses.

Prior Council Action:

11/10/2015:2015-1121

Amount of Funding:

Total Amount of Grant Award: \$3,964,458.00

Federal Government Grant Fund 5000

Contact Information:

Kathy Barton - Telephone: 832-393-5045
Cell: 713-826-5801

ATTACHMENTS:

Description

Signed coversheet/RCA

Type

Signed Cover sheet

TO: Mayor via City Secretary REQUEST FOR COUNCIL ACTION

SUBJECT: An ordinance authorizing the acceptance of a grant award from the Department of Health and Human Services, Centers for Disease Control and Prevention (CDC) for the City's HIV Prevention Program.	Category # 9	Page 1 of 2	Agenda Item #
FROM (Department or other point of origin): Houston Health Department	Origination Date 10/03/2016	Agenda Date	
DIRECTOR'S SIGNATURE: 	Council District affected: ALL		
For additional information contact: Kathy Barton Telephone: 713-794-9998 ; 713-826-5801	Date and identification of prior authorizing Council action: 11/10/2015:2015-1121		

RECOMMENDATION: (Summary) An ordinance authorizing the acceptance of a grant award from the Department of Health and Human Services, Centers for Disease Control and Prevention (CDC) for the City's HIV Prevention Program.

Total Amount of Grant Award: \$3,964,458.00
Federal Government Grant: Fund 5000

Finance Department:

SOURCE OF FUNDING: [] General Fund [X] Grant Fund [] Enterprise Fund [] Other (Specify)

SPECIFIC EXPLANATION: The Houston Health Department (HHD) requests City Council approval of an ordinance authorizing the extension of the project period for a grant application to the United States Department of Health and Human Services, Centers for Disease Control (CDC) for the City's HIV Prevention Activities Reducing HIV Infections and Improve Engagement in HIV Medical Care among Men Who Have Sex With Men (MSM) and Transgender Persons (TG). The budget period is 9/30/2016 through 9/29/2017. The project period is 9/30/2016 through 9/29/2018.

HHD also requests City Council to authorized the Director or his designee to act as the City's representative in the application process with the authority to apply for, accept and expend the grant funds, as awarded, and to apply for and accept and expend all subsequent awards, to extend the budget and/or the project period and authorize the Mayor to execute all related contracts, agreements and documents with the approval of the City Attorney in connection with the grant not to exceed five years.

This project focuses on MSM and transgender people at high risk for HIV infection, particularly people of color. Funding from this grant will allow HHD to implement Pre-exposure prophylaxis (PrEP) activities. PrEP is a combination of two HIV medicines approved for daily use to help prevent an HIV-negative person from getting HIV from a HIV positive sexual or injection-drug-using partner. PrEP activities include:

1. Collecting community baseline level of PrEP awareness and interest among target population by surveying 200 MSM and TG
2. Developing at least one (1) comprehensive tracking process to capture when HIV staff offer PrEP education and refer clients for services, particularly MSM and TG.
3. Increasing media buys and support to prescribe PrEP through awareness building and training opportunities
4. Implementing at least two (2) PrEP referral protocols for HHD to encourage PrEP uptake.
5. Conducting at least three (3) key informant interviews with known PrEP providers about their best practices for Texas-specific reimbursement and billing strategies to integrate into provider technical assistance and provider resources.

REQUIRED AUTHORIZATION

Finance Department	Other Authorization:	Other Authorization:
---------------------------	-----------------------------	-----------------------------

Date 10/03/2016	Subject: An ordinance authorizing the acceptance of a grant award from the Department of Health and Human Services, Centers for Disease Control and Prevention (CDC) for the City's HIV Prevention Program.	Originator's Initials	Page 2 of 2
---------------------------	--	------------------------------	--------------------

This funding opportunity will also allow HHD to use Data to Care, a new public health strategy that uses HIV surveillance data to identify HIV-diagnosed individuals not in care, link them to care, and support the HIV Care Continuum. Using Data to Care to achieve a population-based surveillance estimate of HIV among transgender Houstonians, HHD will:

1. Increase partnerships by 8% for data to care interventions with the 38 documented HIV care providers in Houston.
2. Increase referrals to linkage programs by 25% utilizing the Maven data systems when streamlining referrals.
3. Create new Houston – specific presentations to provide education awareness on the importance of engagement and retention in HIV care to targeted population, specifically, MSM and TG persons.
4. Generate Data-to-Care list identifying 29 TG persons with previous evidence of HIV care.
5. Conduct at least five (5) presentations on HIV care retention and cultural sensitivity at local and national HIV conferences.

Grant funding allows \$1,342,281.00 in personnel costs (20 FTEs) and \$ 2,622,177.00 in program expenses.

cc: Finance Department
Legal Department
Agenda Director



CITY OF HOUSTON - CITY COUNCIL

Meeting Date: 10/25/2016

District H

Item Creation Date: 9/23/2016

HCD16-62 Avenue Community Development Corporation

Agenda Item#: 21.

Summary:

ORDINANCE approving and authorizing amendment to Loan Agreement between the City of Houston and **AVENUE COMMUNITY DEVELOPMENT CORPORATION**, to provide a Performance-Based Loan of an additional \$481,135.00 of Federal Community Block Grant Disaster Relief Program – Rental Housing Projects Round 2 Funds to assist with construction of a 68 unit Mixed-Income Apartment Development, including 52 affordable units, located in Houston, Texas, near 2010 North Main Street - **DISTRICT H - CISNEROS**

Background:

The Housing and Community Development Department recommends Council approve an amendment to the original Loan Agreement executed December 19, 2014, between the City of Houston and Avenue CDC for the construction of Avenue Station, a 68-unit affordable housing development. The original Loan Agreement is a zero (0) percent performance based loan that is forgivable at the end of the ten (10) year affordability period if no default exist. The amendment will allow for a \$481,135 increase to the original \$5,500,000 commitment amount in order to fund cost overruns the project is experiencing due to project delays.

Avenue Station's 68 units will range from one to three bedrooms. Fifty-two units (76%) will be restricted for low-income tenants at affordable rents, and in conjunction with tax credit equity requirements, the affordability will run for a period of 15 years.

The original project completion date was January 2016, however, the delays have the new projected completion date at October 2016. The delays are attributed to the discovery of underground storage tanks, underground utility connection difficulties, inclement weather and sub-contractor issues. These delays have led to increased costs in the form of additional monthly recurring expenses, additional engineering fees, and a reduction in tax credit equity.

The other stakeholders, Capital One (senior lender) and National Equity Fund (tax credit equity provider), have indicated it is neither cost effective nor feasible to re-enter the market for new bond issuance or new debt to cover these costs. Therefore, HCDD recommends Council approve the additional funds request as this development will provide for needed quality affordable housing in the Near Northside community. The overage will be funded through CDBG Disaster Recovery 2 funds, which were anticipated for this purpose.

The developer, Avenue CDC, is a well-respected non-profit organization with a track record of developing high-quality and well-managed affordable housing communities throughout Houston. Their mission is to preserve the area's cultural, economic and historic diversity by developing affordable housing and economic opportunities.

This item was reviewed by the Housing and Community Affairs Committee on June 14, 2016.

Prior Council Action:

12/10/14; (O) 2014-1083

Amount of Funding:

\$481,135.00

Community Development Block Grant-Disaster Recovery Round 2 (CDBG-DR2) - Fund 5000

Contact Information:

Roxanne Lawson

(832) 394-6307

ATTACHMENTS:

Description

Cover Sheet

Type

Signed Cover sheet



CITY OF HOUSTON - CITY COUNCIL

Meeting Date: 10/11/2016

District H

Item Creation Date: 9/23/2016

HCD16-62 Avenue Community Development Corporation

Agenda Item#:

Background:

The Housing and Community Development Department recommends Council approve an amendment to the original Loan Agreement executed December 19, 2014, between the City of Houston and Avenue CDC for the construction of Avenue Station, a 68-unit affordable housing development. The original Loan Agreement is a zero (0) percent performance based loan that is forgivable at the end of the ten (10) year affordability period, if no default exists. The amendment will allow for a \$481,135 increase to the original \$5,500,000 commitment amount in order to fund cost overruns the project is experiencing due to project delays.

Avenue Station's 68 units will range from one to three bedrooms. Fifty-two units (76%) will be restricted for low-income tenants at affordable rents, and in conjunction with tax credit equity requirements, the affordability will run for a period of 15 years.

The original project completion date was January 2016, however, the delays have the new projected completion date at October 2016. The delays are attributed to the discovery of underground storage tanks, underground utility connection difficulties, inclement weather, and sub-contractor issues. These delays have led to increased costs in the form of additional monthly recurring expenses, additional engineering fees, and a reduction in tax credit equity.

The other stakeholders, Capital One (senior lender) and National Equity Fund (tax credit equity provider), have indicated it is neither cost effective nor feasible to re-enter the market for new bond issuance or new debt to cover these costs. Therefore, HCDD recommends Council approve the additional funds requested, as this development will provide for needed quality affordable housing in the Near Northside community. The overage will be funded through CDBG Disaster Recovery 2 funds, which were anticipated for this purpose.

The developer, Avenue CDC, is a well-respected non-profit organization with a track record of developing high-quality and well-managed affordable housing communities throughout Houston. Their mission is to preserve the area's cultural, economic, and historic diversity by developing affordable housing and economic opportunities.

This item was reviewed by the Housing and Community Affairs Committee on June 14, 2016.

Prior Council Action:

12/10/14; (O) 2014-1083

Amount of Funding:

\$481,135.00

Community Development Block Grant-Disaster Recovery Round 2 (CDBG-DR2) - Fund 5000

Tom McCasland, Interim Director

Contact Information:

Roxanne Lawson

(832) 394-6307



CITY OF HOUSTON - CITY COUNCIL

Meeting Date: 10/25/2016

ALL

Item Creation Date: 8/12/2016

HCD16-81 Brentwood Economic Community Development Corporation

Agenda Item#: 22.

Summary:

ORDINANCE approving and authorizing first amendment to contract between the City of Houston and **BRENTWOOD ECONOMIC COMMUNITY DEVELOPMENT CORP., doing business as BRENTWOOD COMMUNITY FOUNDATION**, extending the term of the contract and providing up to \$551,607.75 in Housing Opportunities for Persons with AIDS Funds for the continuing administration and operation of a community residence and the administration of a Short-Term Rent, Mortgage and Utility Assistance Program, along with supportive services

Background:

The Housing and Community Development Department (HCDD) is currently engaged in a one-year contract, which has a one-year renewal option, with Brentwood Economic Community Development Corp., dba Brentwood Community Foundation, to provide funding for the administration and operation of two programs: (1) a HOPWA-funded community residence for men, including supportive services, and (2) a Short-Term Rent, Mortgage, Utility Assistance (STRMUA) Program with supportive services. This amendment exercises the renewal option and extends the contract to January 31, 2018. This amendment will also include an increase to the number of clients served, from 410 to 440, and an increase in funding by 9.5% to cover the cost of the new clients and for security updates needed at the community residence.

The City will grant Brentwood up to **\$551,607.75** in HOPWA funds. The project's scope of work is for rental assistance, budget counseling, and supportive services to approximately 440 low-income households. Brentwood operates an 18-unit transitional housing facility for men living with HIV/AIDS. Through its rental assistance programs, Brentwood provides rental subsidies to help participants at risk of becoming homeless obtain emergency housing assistance. Brentwood provides supportive services, including case management, professional counseling, a substance abuse program and nutritional services. The City provides 83% of the budget for this program and the remaining 17% is from other funding sources.

Category	Total Contract Amount	Percent
Administrative	\$27,721.55	5.03%
Supportive Services	\$115,141.48	20.87%
Short-Term Rent, Mortgage, Utility Program	\$303,644.72	55.05%
Operations: Community Residence	\$105,100.00	19.05%
Total	\$551,607.75	100.00%

HCDD conducted a Request for Proposals (RFP) for HOPWA contracts for fiscal year 2016 with a one-year renewal option for fiscal year 2017. Brentwood was one of the agencies selected. The current contract expires on January 31, 2017 and this Ordinance will extend it to January 31, 2018. Brentwood has received HOPWA funding through the City of Houston for various contracts since 1995.

This item was reviewed by the Housing & Community Affairs Committee on September 20, 2016.

Prior Council Action:

2/3/16; (O) 2016-0103

Amount of Funding:

\$551,607.75

Housing Opportunities for Persons With AIDS (HOPWA) - Fund 5000

Contact Information:

Roxanne Lawson
832.394.6307

ATTACHMENTS:

Description

Signed Coversheet

Type

Signed Cover sheet



CITY OF HOUSTON - CITY COUNCIL

Meeting Date: 10/25/2016

ALL

Item Creation Date: 8/12/2016

HCD16-81 Brentwood Economic Community Development Corporation

Agenda Item#:

Background:

The Housing and Community Development Department (HCDD) is currently engaged in a one-year contract, which has a one-year renewal option, with Brentwood Economic Community Development Corp., dba Brentwood Community Foundation, to provide funding for the administration and operation of two programs: (1) a HOPWA-funded community residence for men, including supportive services, and (2) a Short-Term Rent, Mortgage, Utility Assistance (STRMUA) Program with supportive services. This amendment exercises the renewal option and extends the contract to January 31, 2018. This amendment will also include an increase to the number of clients served, from 410 to 440, and an increase in funding by 9.5% to cover the cost of the new clients and for security updates needed at the community residence.

The City will grant Brentwood up to **\$551,607.75** in HOPWA funds. The project's scope of work is for rental assistance, budget counseling, and supportive services to approximately 440 low-income households. Brentwood operates an 18-unit transitional housing facility for men living with HIV/AIDS. Through its rental assistance programs, Brentwood provides rental subsidies to help participants at risk of becoming homeless obtain emergency housing assistance. Brentwood provides supportive services, including case management, professional counseling, a substance abuse program and nutritional services. The City provides 83% of the budget for this program and the remaining 17% is from other funding sources.

Category	Total Contract Amount	Percent
Administrative	\$27,721.55	5.03%
Supportive Services	\$115,141.48	20.87%
Short-Term Rent, Mortgage, Utility Program	\$303,644.72	55.05%
Operations: Community Residence	\$105,100.00	19.05%
Total	\$551,607.75	100.00%

HCDD conducted a Request for Proposals (RFP) for HOPWA contracts for fiscal year 2016 with a one-year renewal option for fiscal year 2017. Brentwood was one of the agencies selected. The current contract expires on January 31, 2017 and this Ordinance will extend it to January

31, 2018. Brentwood has received HOPWA funding through the City of Houston for various contracts since 1995.

This item was reviewed by the Housing & Community Affairs Committee on September 20, 2016.

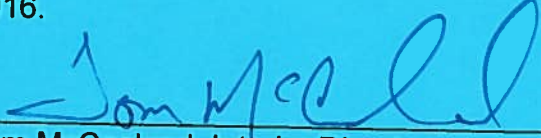

Tom McCasland, Interim Director

Prior Council Action:

2/3/16; (O) 2016-0103

Amount of Funding:

\$551,607.75

Housing Opportunities for Persons With AIDS (HOPWA) - Fund 5000

Contact Information:

Roxanne Lawson

832.394.6307



CITY OF HOUSTON - CITY COUNCIL

Meeting Date: 10/25/2016

ALL

Item Creation Date:

HCD16-77 Catholic Charities of the Archdiocese of Galveston-Houston

Agenda Item#: 23.

Summary:

ORDINANCE approving and authorizing first amendment to contract between the City of Houston and **CATHOLIC CHARITIES OF THE ARCHDIOCESE OF GALVESTON-HOUSTON** extending the term of the contract and providing up to an additional \$995,166.75 in Housing Opportunities for Persons with AIDS Funds for the continuing administration and operation of a tenant- based rental assistance program, a short-term rent, mortgage, and utility assistance program, and the provision of other supportive services

Background:

The Housing and Community Development Department (HCDD) is currently engaged in a one-year contract, which has a one-year renewal option, with Catholic Charities of the Archdiocese of Galveston-Houston, to provide funding for the administration and operation of two programs: (1) Tenant-Based Rental Assistance Program with supportive services and (2) Short-Term Rent, Mortgage, and Utility Assistance Program with supportive services. This amendment exercises the renewal option and extends the contract to November 30, 2017. This amendment will also include an increase in funding by 1.3% to increase employee salaries and fringe benefits in accordance with Department of Labor's Final Rule 29 CFR 541 regarding over-time payment for qualifying salaried employees.

The City will grant Catholic Charities up to **\$995,166.75** in HOPWA funds. The project's scope of work provides housing assistance and supportive services to approximately 145 low-income households. The agency's AIDS Ministry is a holistic program providing case management, as well as housing and financial assistance for persons infected and/or affected by HIV/AIDS. The City provides approximately 97% of the budget for this program, and 3% is provided by other funding sources.

Category	Total Contract Amount	Percent
Administrative	\$68,700.00	7%
Supportive Services	\$212,286.25	21%
Supportive Services – Permanent Housing Placement (Deposits)	\$20,000.00	2%
Tenant-Based Rental Assistance Program	\$328,394.88	33%
Short-Term Rent, Mortgage, Utility Program	\$365,785.62	37%
Total	\$995,166.75	100.00%

HCDD conducted a Request for Proposals (RFP) for HOPWA contracts for fiscal year 2016 with a one-year renewal option for fiscal year 2017. Catholic Charities was one of the agencies selected. The current contract expires on November 30, 2016 and this Ordinance will extend it to November 30, 2017. Catholic Charities has received HOPWA funding through the City of Houston for various contracts since 2003.

This item was reviewed by the Housing & Community Affairs Committee on September 20, 2016.

Prior Council Action:

1/20/16; (O) 2016-0046

Amount of Funding:

\$995,166.75

3995,100.75

Housing Opportunities for Persons With AIDS (HOPWA) - Fund 5000

Contact Information:

Roxanne Lawson

832.394.6307

ATTACHMENTS:

Description

Cover Sheet

Type

Signed Cover sheet



CITY OF HOUSTON - CITY COUNCIL

Meeting Date: 10/25/2016

ALL

Item Creation Date:

HCD16-77 Catholic Charities of the Archdiocese of Galveston-Houston

Agenda Item#:

Background:

The Housing and Community Development Department (HCDD) is currently engaged in a one-year contract, which has a one-year renewal option, with Catholic Charities of the Archdiocese of Galveston-Houston, to provide funding for the administration and operation of two programs: (1) Tenant-Based Rental Assistance Program with supportive services and (2) Short-Term Rent, Mortgage, and Utility Assistance Program with supportive services. This amendment exercises the renewal option and extends the contract to November 30, 2017. This amendment will also include an increase in funding by 1.3% to increase employee salaries and fringe benefits in accordance with Department of Labor's Final Rule 29 CFR 541 regarding over-time payment for qualifying salaried employees.

The City will grant Catholic Charities up to **\$995,166.75** in HOPWA funds. The project's scope of work provides housing assistance and supportive services to approximately 145 low-income households. The agency's AIDS Ministry is a holistic program providing case management, as well as housing and financial assistance for persons infected and/or affected by HIV/AIDS. The City provides approximately 97% of the budget for this program, and 3% is provided by other funding sources.

Category	Total Contract Amount	Percent
Administrative	\$68,700.00	7%
Supportive Services	\$212,286.25	21%
Supportive Services – Permanent Housing Placement (Deposits)	\$20,000.00	2%
Tenant-Based Rental Assistance Program	\$328,394.88	33%
Short-Term Rent, Mortgage, Utility Program	\$365,785.62	37%
Total	\$995,166.75	100.00%

HCDD conducted a Request for Proposals (RFP) for HOPWA contracts for fiscal year 2016 with a one-year renewal option for fiscal year 2017. Catholic Charities was one of the agencies selected. The current contract expires on November 30, 2016 and this Ordinance will extend it to November 30, 2017. Catholic Charities has received HOPWA funding through the City of Houston for various contracts since 2003.

This item was reviewed by the Housing & Community Affairs Committee on September 20, 2016.

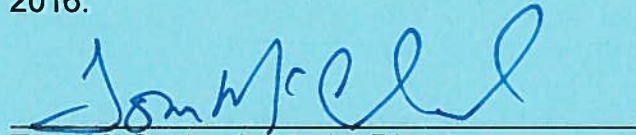

Tom McCasland, Interim Director

Prior Council Action:

1/20/16; (O) 2016-0046

Amount of Funding:

\$995,166.75

Housing Opportunities for Persons With AIDS (HOPWA) - Fund 5000

Contact Information:

Roxanne Lawson

832.394.6307



CITY OF HOUSTON - CITY COUNCIL

Meeting Date: 10/25/2016

ALL

Item Creation Date: 8/18/2016

HCD16-90 Houston SRO Housing Corporation

Agenda Item#: 24.

Summary:

ORDINANCE approving and authorizing first amendment to contract between the City of Houston and **HOUSTON SRO HOUSING CORPORATION** to extend the term of the contract and provide up to \$141,365.00 in Housing Opportunities for Persons With AIDS Funds for the operation of a Single Room Occupancy/Community Residence and the provision of other supportive services

Background:

The Housing and Community Development Department (HCDD) recommends approval of a first contract amendment exercising the renewal option between the City of Houston and Houston SRO Housing Corporation to finance the administration and operation of a HOPWA community residence with supportive services.

The City will grant Houston SRO Housing Corporation (Houston SRO) \$141,365 to operate a HOPWA community residence and provide permanent housing and supportive services for low-income persons affected by HIV/AIDS. Houston SRO anticipates serving 35 clients annually. The target population typically consists of individuals who have experienced ongoing substance abuse issues and mental illness. Supportive services include comprehensive case management and referrals for medical, dental, job training, job placement, mental health counseling, and substance abuse counseling. Operating costs include property management, utilities, property insurance, and other costs. HOPWA funds are providing 60% of the cost of this program.

Category	Total Contract Services	Percent
Administrative	\$9,691	7%
Supportive Services	\$21,730	15%
Operating Costs	\$109,944	78%
Total	\$141,365	100%

HCDD conducted a Request for Proposals (RFP) for HOPWA contracts for fiscal year 2016, with a one-year renewal option for fiscal year 2017. Houston SRO was one of the agencies selected. This first contract amendment exercises the option for fiscal year 2017, and provides funding from December 1, 2016 – November 30, 2017.

Houston SRO began receiving HOPWA funds through the City in 1998.

The Housing and Community Affairs Committee reviewed this item on September 20, 2016.

Prior Council Action:

1/20/16; (O) 2016-0047

Amount of Funding:

\$141,365.00

Housing Opportunities for Persons With AIDS (HOPWA) - Fund 5000

Contact Information:

Roxanne Lawson

832.394.6307

ATTACHMENTS:

Description

Cover Sheet

Type

Signed Cover sheet



CITY OF HOUSTON - CITY COUNCIL

Meeting Date: 10/25/2016

ALL

Item Creation Date: 8/18/2016

HCD16-90 Houston SRO Housing Corporation

Agenda Item#:

Background:

The Housing and Community Development Department (HCDD) recommends approval of a first contract amendment exercising the renewal option between the City of Houston and Houston SRO Housing Corporation to finance the administration and operation of a HOPWA community residence with supportive services.

The City will grant Houston SRO Housing Corporation (Houston SRO) \$141,365 to operate a HOPWA community residence and provide permanent housing and supportive services for low-income persons affected by HIV/AIDS. Houston SRO anticipates serving 35 clients annually. The target population typically consists of individuals who have experienced ongoing substance abuse issues and mental illness. Supportive services include comprehensive case management and referrals for medical, dental, job training, job placement, mental health counseling, and substance abuse counseling. Operating costs include property management, utilities, property insurance, and other costs. HOPWA funds are providing 60% of the cost of this program.

Category	Total Contract Services	Percent
Administrative	\$9,691	7%
Supportive Services	\$21,730	15%
Operating Costs	\$109,944	78%
Total	\$141,365	100%

HCDD conducted a Request for Proposals (RFP) for HOPWA contracts for fiscal year 2016, with a one-year renewal option for fiscal year 2017. Houston SRO was one of the agencies selected. This first contract amendment exercises the option for fiscal year 2017, and provides funding from December 1, 2016 – November 30, 2017.

Houston SRO began receiving HOPWA funds through the City in 1998.

The Housing and Community Affairs Committee reviewed this item on September 20, 2016.

Tom McCasland, Interim Director

Prior Council Action:

1/20/16; (O) 2016-0047

Amount of Funding:

\$141,365.00

Housing Opportunities for Persons With AIDS (HOPWA) - Fund 5000

Contact Information:

Roxanne Lawson

832.394.6307



CITY OF HOUSTON - CITY COUNCIL

Meeting Date: 10/25/2016

ALL

Item Creation Date: 8/12/2016

HCD16-79 SEARCH Homeless Services

Agenda Item#: 25.

Summary:

ORDINANCE approving and authorizing first amendment to contract between the City of Houston and **SEARCH HOMELESS SERVICES formerly SERVICE OF THE EMERGENCY AID RESOURCE CENTER FOR THE HOMELESS, INC**, to extend the term of the contract and provide up to \$144,551.00 in Housing Opportunities for Persons With AIDS Funds for the continuing administration and operation of a Supportive Services Program offering childcare for homeless families affected by HIV/AIDS

Background:

The Housing and Community Development Department (HCDD) is currently engaged in a one-year contract, which has a one-year renewal option, with SEARCH Homeless Services, to provide funding for the administration and operation of a childcare services program for HIV-positive individuals and their children through SEARCH's House of Tiny Treasures, an early childhood development childcare facility. This amendment exercises the renewal option and extends the contract to November 30, 2017.

The City will grant SEARCH Homeless Services up to **\$144,551** in HOPWA funds. The project's scope of work is to provide early childhood education to 19 homeless children who are living with HIV/AIDS. The services enable the families of such children to lead stable and functional lives. Supportive services will be provided to 35 individuals consisting of parents, family members or primary caretakers infected with HIV/AIDS. Support services will include case management, counseling and referral services to support the basic and emotional needs of those living with HIV/AIDS. The City provides 25% of the budget for this program, while the remaining 75% is provided by other funding sources.

Category	Total Contract Amount	Percent
Administrative	\$9,762.00	6.75%
Supportive Services	\$134,789.00	93.25%
Total	\$144,551.00	100.00%

HCDD conducted a Request for Proposals (RFP) for HOPWA contracts for fiscal year 2016 with a one-year renewal option for fiscal year 2017. SEARCH Homeless Services was one of the agencies selected. The current contract expires on November 30, 2016, and this Ordinance will extend it to November 30, 2017. SEARCH Homeless Services has received HOPWA funding through the City of Houston for various contracts since 1996.

This item was reviewed by the Housing & Community Affairs Committee on September 20, 2016.

Prior Council Action:

1/20/16; (O) 2016-0045

Amount of Funding:

\$144,551.00

Housing Opportunities for Persons With AIDS (HOPWA) - Fund 5000

Contact Information:

Roxanne Lawson

832.394.6307

ATTACHMENTS:

Description

Cover Sheet

Type

Signed Cover sheet



CITY OF HOUSTON - CITY COUNCIL

Meeting Date: 10/25/2016

ALL

Item Creation Date: 8/12/2016

HCD16-79 SEARCH Homeless Services

Agenda Item#:

Background:

The Housing and Community Development Department (HCDD) is currently engaged in a one-year contract, which has a one-year renewal option, with SEARCH Homeless Services, to provide funding for the administration and operation of a childcare services program for HIV-positive individuals and their children through SEARCH's House of Tiny Treasures, an early childhood development childcare facility. This amendment exercises the renewal option and extends the contract to November 30, 2017.

The City will grant SEARCH Homeless Services up to **\$144,551** in HOPWA funds. The project's scope of work is to provide early childhood education to 19 homeless children who are living with HIV/AIDS. The services enable the families of such children to lead stable and functional lives. Supportive services will be provided to 35 individuals consisting of parents, family members or primary caretakers infected with HIV/AIDS. Support services will include case management, counseling and referral services to support the basic and emotional needs of those living with HIV/AIDS. The City provides 25% of the budget for this program, while the remaining 75% is provided by other funding sources.

Category	Total Contract Amount	Percent
Administrative	\$9,762.00	6.75%
Supportive Services	\$134,789.00	93.25%
Total	\$144,551.00	100.00%

HCDD conducted a Request for Proposals (RFP) for HOPWA contracts for fiscal year 2016 with a one-year renewal option for fiscal year 2017. SEARCH Homeless Services was one of the agencies selected. The current contract expires on November 30, 2016, and this Ordinance will extend it to November 30, 2017. SEARCH Homeless Services has received HOPWA funding through the City of Houston for various contracts since 1996.

This item was reviewed by the Housing & Community Affairs Committee on September 20, 2016.

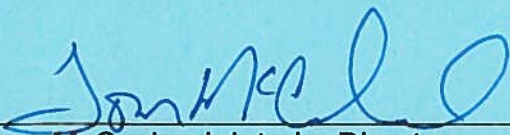

Tom McCasland, Interim Director

Prior Council Action:

1/20/16; (O) 2016-0045

Amount of Funding:

\$144,551.00

Housing Opportunities for Persons With AIDS (HOPWA) - Fund 5000

Contact Information:

Roxanne Lawson

832.394.6307



CITY OF HOUSTON - CITY COUNCIL

Meeting Date: 10/25/2016

District I

Item Creation Date: 10/6/2016

HAS - Lease BPM Airport, LLC at Hobby Airport

Agenda Item#: 26.

Summary:

ORDINANCE approving and authorizing Lease Agreement between the City of Houston and **BPM AIRPORT, LLC**, for certain premises at William P. Hobby Airport - **DISTRICT I - GALLEGOS**

Background:

BPM Airport, LLC, a plastics company (Lessee), has requested to lease a driveway located at 8031 Airport Blvd., William P. Hobby Airport (HOU).

The pertinent terms and conditions of the lease agreement are as follows:

1. Premises: Approximately 2,148 square feet of driveway at 8031 Airport Blvd., HOU.
2. Term: The term is for fifteen (15) years from the date of countersignature (Effective Date), unless sooner terminated in accordance with the lease.
3. Use: Lessee shall use the leased premises as a driveway access to their adjacent property.
4. Rent: \$937.00 annually
5. Performance Security: Lessee shall provide a performance bond or an irrevocable letter of credit in the amount of \$937.00, which represents one year's rent.
6. Maintenance And Utilities: Lessee shall assume the entire responsibility, cost and expense for all repair and maintenance of the leased premises.
7. Indemnification and Insurance: Lessee shall indemnify and hold the City harmless and shall provide the required insurance in the limits as stated in the lease.
9. Environmental and Airport Rules: Lessee shall comply with all federal, state and local environmental laws and all airport policies and procedures.
10. Other: Lessee agrees to comply with all rules and regulations adopted by the airport and/or TSA and/or the FAA, and to comply with all federal, state and local statutes, ordinances, regulations and policies.

Director's Signature:

Mario C. Diaz
Houston Airport System

Amount of Funding:

REVENUE: \$937.00 per year

Contact Information:

Rhonda Arnold 2/233-1618
Ian Wadsworth 2/233-1682

ATTACHMENTS:

Description

Signed Coversheet - BPM

Type

Signed Cover sheet



CITY OF HOUSTON - CITY COUNCIL

Meeting Date: 10/25/2016

District I

Item Creation Date: 10/6/2016

HAS - Lease BPM Airport, LLC at Hobby Airport

Agenda Item#: 14.

Background:

BPM Airport, LLC, a plastics company (Lessee), has requested to lease a driveway located at 8031 Airport Blvd., William P. Hobby Airport (HOU).

The pertinent terms and conditions of the lease agreement are as follows:

1. Premises: Approximately 2,148 square feet of driveway at 8031 Airport Blvd., HOU.
2. Term: The term is for fifteen (15) years from the date of countersignature (Effective Date), unless sooner terminated in accordance with the lease.
3. Use: Lessee shall use the leased premises as a driveway access to their adjacent property.
4. Rent: \$937.00 annually
5. Performance Security: Lessee shall provide a performance bond or an irrevocable letter of credit in the amount of \$937.00, which represents one year's rent.
6. Maintenance And Utilities: Lessee shall assume the entire responsibility, cost and expense for all repair and maintenance of the leased premises.
7. Indemnification and Insurance: Lessee shall indemnify and hold the City harmless and shall provide the required insurance in the limits as stated in the lease.
9. Environmental and Airport Rules: Lessee shall comply with all federal, state and local environmental laws and all airport policies and procedures.
10. Other: Lessee agrees to comply with all rules and regulations adopted by the airport and/or TSA and/or the FAA, and to comply with all federal, state and local statutes, ordinances, regulations and policies.

Director's Signature:

A handwritten signature in black ink, appearing to read "Mark C. Diaz".

Mark C. Diaz
Houston Airport System

Amount of Funding:

REVENUE: \$937.00 per year

Contact Information:

Rhonda Arnold 2/233-1618
Ian Wadsworth 2/233-1682



CITY OF HOUSTON - CITY COUNCIL

Meeting Date: 10/25/2016

District A, District E, District F, District J, ETJ

Item Creation Date: 10/19/2016

PLN - SPAs Fall 2016 - Ordinance Amending the Ordinance
2016-755 Calling Public Hearings

Agenda Item#: 27.

Summary:

ORDINANCE amending Ordinance 2016-755 calling public hearings at which interested persons will be given the opportunity to be heard on: proposed amendments to the Strategic Partnership Agreements between the City of Houston and **FORT BEND COUNTY MUNICIPAL UTILITY DISTRICT NO. 142** and **MONTGOMERY COUNTY UTILITY DISTRICT NO. 119** and on a proposal to annex for limited purposes territory located within and in the vicinity of such districts in Fort Bend and Montgomery Counties; proposed amendments to Strategic Partnership Agreements between the City of Houston and **LAKE FOREST UTILITY DISTRICT, REID ROAD MUNICIPAL UTILITY DISTRICT NO. 1, and TRAIL OF THE LAKES MUNICIPAL UTILITY DISTRICT** and on proposals for the City of Houston to annex for limited purposes certain territory located within such districts in Harris County; proposals of the City of Houston to impose the City of Houston's Sales and Use Tax in such territories; providing for the publication of notice of such hearings - **DISTRICTS A - STARDIG; E - MARTIN and F - LE**
HEARING DATES - 9:00 A.M. - WEDNESDAY - NOVEMBER 9 and 16, 2016

Background:

In 1999, the State Legislature changed the annexation laws in Texas. The changes significantly limited a municipality's options for conducting full purpose (also called general purpose) annexations and expanded a municipality's ability to annex for limited purpose through a Strategic Partnership Agreement with utility districts. Such agreements allow the City to annex all or part of a district for limited purposes. The City can then charge a sales tax and provide specified, limited services to the area. The City cannot levy a property tax in areas annexed for limited purposes.

Since the inception of the Strategic Partnership Agreements in 2000, the City of Houston has executed such agreements with 237 utility districts. Without exception, these agreements have been the result of a request by the district itself, and state law requires that the district approve the agreement prior to Council's consideration of it. At the beginning of a new "round" of annexations, the City will send a general announcement to area districts, and those that are interested respond. When a district enters into an agreement with the City for the first time, a new Strategic Partnership Ordinance is created. Subsequent Ordinances between the same district and the City to change boundaries or contract terms are approved as amendments to existing Agreements.

These agreements have created net revenue of approximately \$51 million to the City in 2015 and, because the split is usually 50/50, these agreements have led to around \$51 million being

redistributed back to the community through the utility districts. While the City does not monitor the expenditures of each district, we are aware that most districts use their funds to supplement existing district services, which effectively lowers utility and tax rates. In some instances, districts have used the proceeds to fund regional parks and other public amenities. Through these agreements, the City has maintained a good working relationship with the utility districts in the Houston area.

The City is holding these hearings in accordance with Section 43.075 of the Texas Local Government Code, which states: Before the governing body of a municipality or a district adopts a Strategic Partnership Agreement, it shall conduct two public hearings at which members of the public who wish to present testimony or evidence regarding the proposed agreement shall be given the opportunity to do so.

The hearings called by this ordinance are for amendments to existing agreements, with the following Utility Districts:

Amendments to existing Agreements:

Fort Bend County MUD 142 (Amendment 2)

Lake Forest UD (Amendment 2)

Montgomery County MUD 119 (Amendment 1)

Reid Road MUD 1 (Amendment 2)

Trail of the Lakes MUD (Amendment 1)

Each of these amendments will add commercial property and undeveloped land intended for commercial use to the existing agreement. There is no population located in these territories proposed to be annexed for limited purposes. In addition, the city will levy a 1 percent sales tax and the taxes collected in the areas will be divided evenly between the City and the District.

The hearings will be held on November 9, 2016 and November 16, 2016 in City Council chambers.

Patrick Walsh, P.E.
Director
Planning and Development Department

Contact Information:

Rupesh Koshy
Phone: 832-393-6552

ATTACHMENTS:

Description

Type



CITY OF HOUSTON - CITY COUNCIL

Meeting Date: 10/25/2016

ALL

Item Creation Date: 10/11/2016

LGL - Clarence West - Agreement for Legal Services

Agenda Item#: 28.

Summary:

ORDINANCE amending Ordinance No. 2005-0619, as amended, to increase the maximum contract amount for agreement for Professional Legal Services (Contract No. C56949) between the City and **CLARENCE A. WEST, ATTORNEY AT LAW**

Background:

Under the Agreement for Professional Services Contract C56949 ("Agreement"), Clarence A. West provides legal services to the City related to various telecommunication matters and right-of-way matters, including a complaint filed by Extenet Inc., against City of Houston at the Public Utility Commission of Texas ("PUC").

The City continues to desire Mr. West's assistance with the Extenet complaint at the PUC and other wireless communication matters. In addition to his telecommunications expertise, Mr. West brings specialized knowledge about past cases, hearings, and events that are not publicly available and cannot be easily found or known.

Recommendation: It is recommended that City Council approve the ordinance amending the Agreement to authorize an additional \$50,000 to the contract to cover the continuing costs of the Extenet complaint at the PUC and other wireless communication matters

MWBE participation: zero-percentage goal document was approved by the Office of Business Opportunity

Pay or Play Program: The existing contract was executed prior to the effective date of the City's 'Pay or Play' ordinance ("POP"); thus, it is not subject to the POP requirements.

Hire Houston First: the existing contract was executed prior to the effective date of the City's Hire Houston First ("HHF") Ordinance; thus, it is not subject to the HHF requirements.

Fiscal Note: Funding for this item is included in the FY2017 Adopted Budget. Therefore, no fiscal note is required as stated in the Financial Policy Ordinance No. 2014-1078.

Ronald C. Lewis
City Attorney

Prior Council Action:

Ord 2005-0619 (May 11, 2005)
Ord 2015-0972 (October 14, 2015)

Amount of Funding:

Property & Casualty Fund (1004)

Supplemental Allocation \$50,000
\$290,000 maximum contract amount

Contact Information:

YuShan Chang, 832-393-6442

ATTACHMENTS:

Description

RCA

Type

Signed Cover sheet

TO: Mayor via City Secretary

REQUEST FOR COUNCIL ACTION

SUBJECT: An ordinance amending Ordinance No. 2005-0619, as amended, to increase the maximum contract amount for an agreement for professional legal services (Contract No. C56949) between the City of Houston and Clarence A. West, Attorney at Law.		Page 1 of 1	Agenda Item #
FROM (Department or other point of origin): Legal Department		Origination Date 10/10/16	Agenda Date
DIRECTOR'S SIGNATURE: Ronald C. Lewis, City Attorney 		Council District affected: All	
For additional information contact: YuShan Chang, 832-393-6442		Date and identification of prior authorizing Council action: Ord 2005-0619 (May 11, 2005) Ord 2015-0972 (October 14, 2015)	
RECOMMENDATION: (Summary) Adopt an ordinance amending Ordinance No. 2005-0619, as amended, to increase the maximum contract amount for an agreement for professional legal services between the City of Houston and Clarence A. West, Attorney at Law			
Amount and Source of Funding: Property & Casualty Fund (1004) Supplemental Allocation \$50,000 \$290,000 maximum contract amount			
BACKGROUND: <p>Under the Agreement for Professional Services Contract C56949 ("Agreement"), Clarence A. West provides legal services to the City related to various telecommunication matters and right-of-way matters, including a complaint filed by Extenet Inc., against City of Houston at the Public Utility Commission of Texas ("PUC").</p> <p>The City continues to desire Mr. West's assistance with the Extenet complaint at the PUC and other wireless communication matters. In addition to his telecommunications expertise, Mr. West brings specialized knowledge about past cases, hearings, and events that are not publicly available and cannot be easily found or known.</p> <p>Recommendation: It is recommended that City Council approve the ordinance amending the Agreement to authorize an additional \$50,000 to the contract to cover the continuing costs of the Extenet complaint at the PUC and other wireless communication matters</p> <p>MWBE participation: zero-percentage goal document was approved by the Office of Business Opportunity</p> <p>Pay or Play Program: The existing contract was executed prior to the effective date of the City's 'Pay or Play' ordinance ("POP"); thus, it is not subject to the POP requirements.</p> <p>Hire Houston First: the existing contract was executed prior to the effective date of the City's Hire Houston First ("HHF") Ordinance; thus, it is not subject to the HHF requirements.</p> <p>Fiscal Note: Funding for this item is included in the FY2017 Adopted Budget. Therefore, no fiscal note is required as stated in the Financial Policy Ordinance No. 2014-1078.</p>			
Other Authorization			



CITY OF HOUSTON - CITY COUNCIL

Meeting Date: 10/25/2016

District C

Item Creation Date: 9/6/2016

PLN - Special Minimum Lot Size Block App 617 (1400 Block of Michigan Street, north side)

Agenda Item#: 29.

Summary:

ORDINANCE establishing the north side of the 1400 block of Michigan Street, within the City of Houston as a special minimum lot size block pursuant to Chapter 42 of the Code of Ordinances, Houston, Texas - **DISTRICT C - COHEN**

Background:

In accordance with Section 42-197 of the Code of Ordinances, the property owner of Lot 5 and Tract 4, Block 23, of the Hyde Park Addition Subdivision initiated an application for the designation of a Special Minimum Lot Size Block (SMLSB). The application includes written evidence of support from the owners of 67% of the block. The Planning and Development Department mailed notifications to six (6) property owners indicating that the SMLSB application had been submitted. The notification further stated that written protest must be filed with the Planning and Development Department within thirty days of mailing. One protest was filed. The Houston Planning Commission considered the application on September 1, 2016 and voted to recommend that the City Council establish the SMLSB.

The Planning and Development Department recommends that City Council adopt an ordinance establishing a Special Minimum Lot Size of 6,250 square feet for the 1400 block of Michigan Street, north side.

Patrick Walsh, P.E.
Director
Planning and Development Department

Prior Council Action:

N/A

Amount of Funding:

N/A

Contact Information:

David Welch, Planner I

Phone: 832-393-6638

ATTACHMENTS:

Description

Signed Cover Sheet

MLS 617 Boundary Map

Type

Signed Cover sheet

Backup Material



CITY OF HOUSTON - CITY COUNCIL

Meeting Date:
District C
Item Creation Date: 9/6/2016

PLN - Special Minimum Lot Size Block App 617 (1400 Block of Michigan Street, north side)

Agenda Item#:

Background:

In accordance with Section 42-197 of the Code of Ordinances, the property owner of Lot 5 and Tract 4, Block 23, of the Hyde Park Addition Subdivision initiated an application for the designation of a Special Minimum Lot Size Block (SMLSb). The application includes written evidence of support from the owners of 67% of the block. The Planning and Development Department mailed notifications to six (6) property owners indicating that the SMLSb application had been submitted. The notification further stated that written protest must be filed with the Planning and Development Department within thirty days of mailing. One protest was filed. The Houston Planning Commission considered the application on September 1, 2016 and voted to recommend that the City Council establish the SMLSb.

The Planning and Development Department recommends that City Council adopt an ordinance establishing a Special Minimum Lot Size of 6,250 square feet for the 1400 block of Michigan Street, north side.

Patrick Walsh, P.E.
Director
Planning and Development Department

Prior Council Action:

N/A

Amount of Funding:

N/A

Contact Information:

David Welch, Planner I
Phone: 832-393-6638

ATTACHMENTS:

Description

MLS 617 Boundary Map

Type

Backup Material

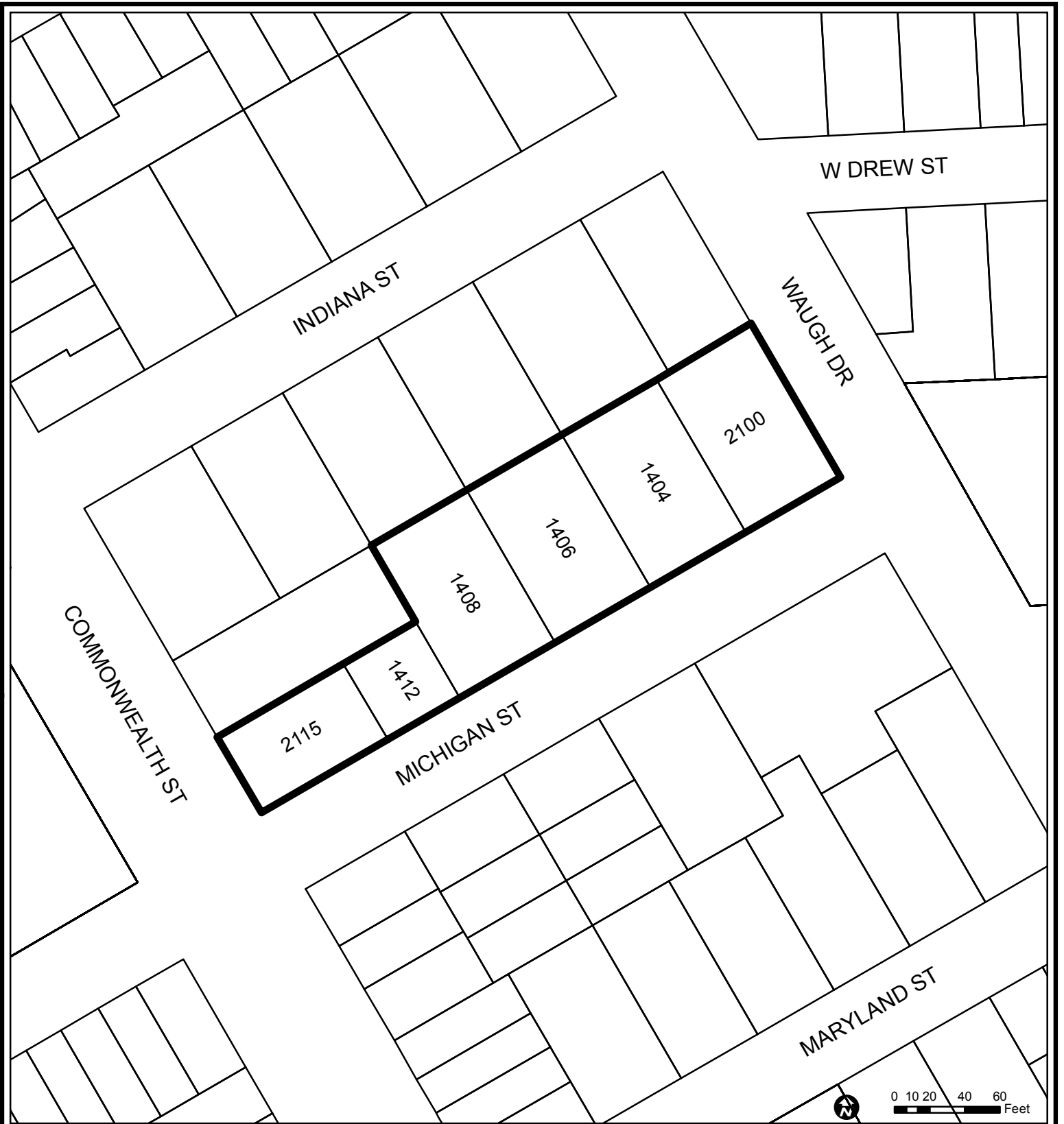

Special Minimum Lot Size
1400 block of Michigan Street
North side, between Commonwealth Street and Waugh Drive
6,250 Square Feet

Source: Harris County Appraisal District
 Date: July 5, 2016
 Reference: MLS 617

This map is made available for reference purposes only and should not be substituted for a survey product. The City of Houston will not accept liability of any kind in conjunction with its use.

 Special Minimum Lot Size Boundary



**PLANNING &
 DEVELOPMENT
 DEPARTMENT**



CITY OF HOUSTON - CITY COUNCIL

Meeting Date: 10/25/2016

ALL

Item Creation Date: 10/10/2016

T25698 Sales and Use Tax Audit Services - ORDINANCE

Agenda Item#: 30.

Summary:

ORDINANCE approving and authorizing contract between the City and **MUNISERVICES, LLC** for Sales/Use Tax Audit and Sales/Use Tax Analysis and Reporting Services; providing a maximum contract amount - 3 Years with 2 one-year options - \$3,150,000.00 - General Fund

Background:

Request for Proposal S66-T25698 - Approve an ordinance awarding a contract to MuniServices, LLC in an amount not to exceed \$3,150,000.00 for Sales and Use Tax Audit (SUTA) Services for the Finance Department.

Specific Explanation:

The Director of Finance and the Chief Procurement Officer recommend the City Council approve an ordinance awarding a three-year contract, with two one-year options to MuniServices, LLC in the amount not to exceed \$3,150,000.00 for sales and use tax audit services for the Finance Department. The Director of Finance or the City Attorney may terminate this agreement by giving 30 days written notice of such termination to the contractor with a copy of the notice to the Chief Procurement Officer.

The scope of work requires the contractor to perform a review of the City's businesses' sales/use tax remittances in an effort to ensure proper application of local sales/use tax law and achieve past and/or prospective compliance, as applicable. MuniServices, LLC will assist in the preparation and filing of amended returns and/or reallocation requests with the Texas Comptroller of Public Accounts (TCPA) in order to gain compliance. The contractor, on the City's behalf, may also provide additional documentation and supporting details to the TCPA to request its assistance in gaining compliance from taxpayers as needed.

The Request for Proposal (RFP) No. S66-T25698 was advertised in accordance with the requirements of the State of Texas bid laws. As a result, three (3) proposals were received, from Muniservices LLC, Sales Tax Group and Texas City Services, LLC.

The Evaluation Committee (EC) consisted of three members from the Finance Department. The proposals were evaluated based on the following criteria:

1. Responsiveness of Proposal
2. Technical Competence

3. Price Proposal

MuniServices, LLC was deemed most qualified based on the proposal to perform the required services as outlined in the RFP.

M/WBE Participation:

This RFP was issued with a five percent (5%) M/WBE participation goal. The goal modification was approved by the Office of Business Opportunity.

Name	Type of Work	Dollar Amount	Percentage
Decision Information Resources	Economic Analysis & Tax Examination	\$78,000.00	2.47%
Sales Tax Assurance	Tax Examination Services	\$100,000.00	3.17%

Pay or Play Program:

The proposed contract requires compliance with the City's 'Pay or Play' ordinance regarding health benefits for employees of City contractors. In this case, the contractor provides health benefits to eligible employees in compliance with City policy.

Hire Houston First:

The proposed contract requires compliance with the City's Hire Houston First (HHF) ordinance that promotes economic opportunity for Houston businesses and supports job creation. In this case MuniServices, LLC is a designated HHF company, but they were the successful awardee without application of the HHF preference.

Fiscal Note:

Funding for this item is included in the FY2017 Adopted Budget. Therefore, no Fiscal Note is required as stated in the Financial Policy Ord. 2014-1078.

John J. Gillespie, Chief Procurement Officer
Finance/Strategic Procurement Division

Department Approval Authority Signature

Estimated Spending Authority

Department	FY2017	Out Years	Total
Finance	\$450,000.00	\$2,700,000.00	\$3,150,000.00

Amount of Funding:

\$3,150,000.00

General Fund (1000)

Contact Information:

Name	Department	Phone
Arif Rasheed, Deputy Director	Finance	(832) 393-9013
Gloria Moreno, Deputy Assistant Director	Finance	(832) 393-9005
Shannon Pleasant, Sr. Procurement Spec.	Finance	(832) 393-8741

ATTACHMENTS:

Description

Signed Cover Sheet

MWBE Modification Approval

Type

Signed Cover sheet

Backup Material

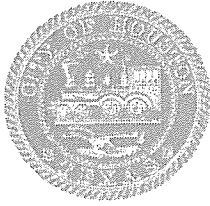

CITY OF HOUSTON - CITY COUNCIL

Meeting Date: 10/25/2016

ALL

Item Creation Date: 10/10/2016

T25698 Sales and Use Tax Audit Services - ORDINANCE

Agenda Item#: 11.

Summary:

AN ORDINANCE APPROVING AND AUTHORIZING A CONTRACT BETWEEN THE CITY AND MUNISERVICES, LLC FOR SALES/USE TAX AUDIT AND SALES/USE TAX ANALYSIS AND REPORTING SERVICES; PROVIDING A MAXIMUM CONTRACT AMOUNT; CONTAINING PROVISIONS RELATING TO THE SUBJECT; AND DECLARING AN EMERGENCY.

Background:

Request for Proposal S66-T25698 - Approve an ordinance awarding a contract to MuniServices, LLC in an amount not to exceed \$3,150,000.00 for Sales and Use Tax Audit (SUTA) Services for the Finance Department.

Specific Explanation:

The Director of Finance and the Chief Procurement Officer recommend the City Council approve an ordinance awarding a three-year contract, with two one-year options to MuniServices, LLC in the amount not to exceed \$3,150,000.00 for sales and use tax audit services for the Finance Department. The Director of Finance or the City Attorney may terminate this agreement by giving 30 days written notice of such termination to the contractor with a copy of the notice to the Chief Procurement Officer.

The scope of work requires the contractor to perform a review of the City's businesses' sales/use tax remittances in an effort to ensure proper application of local sales/use tax law and achieve past and/or prospective compliance, as applicable. MuniServices, LLC will assist in the preparation and filing of amended returns and/or reallocation requests with the Texas Comptroller of Public Accounts (TCPA) in order to gain compliance. The contractor, on the City's behalf, may also provide additional documentation and supporting details to the TCPA to request its assistance in gaining compliance from taxpayers as needed.

The Request for Proposal (RFP) No. S66-T25698 was advertised in accordance with the requirements of the State of Texas bid laws. As a result, three (3) proposals were received, from Muniservices LLC, Sales Tax Group and Texas City Services, LLC.

The Evaluation Committee (EC) consisted of three members from the Finance Department. The proposals were evaluated based on the following criteria:

- 1. Responsiveness of Proposal
- 2. Technical Competence
- 3. Price Proposal

MuniServices, LLC was deemed most qualified based on the proposal to perform the required services as outlined in the RFP.

M/WBE Participation:

This RFP was issued with a five percent (5%) M/WBE participation goal. The goal modification was approved by the Office of Business Opportunity.

Name	Type of Work	Dollar Amount	Percentage
Decision Information Resources	Economic Analysis & Tax Examination	\$78,000.00	2.47%
	Tax Examination Services	\$100,000.00	3.17%
Sales Tax Assurance			

Pay or Play Program:

The proposed contract requires compliance with the City's 'Pay or Play' ordinance regarding health benefits for employees of City contractors. In this case, the contractor provides health benefits to eligible employees in compliance with City policy.

Hire Houston First:

The proposed contract requires compliance with the City's Hire Houston First (HHF) ordinance that promotes economic opportunity for

Houston businesses and supports job creation. In this case MuniServices, LLC is a designated HHF company, but they were the successful awardee without application of the HHF preference.

Fiscal Note:

Funding for this item is included in the FY2017 Adopted Budget. Therefore, no Fiscal Note is required as stated in the Financial Policy Ord. 2014-1078.



John J. Gillespie, Chief Procurement Officer
Finance/Strategic Procurement Division

Department Approval Authority Signature

Estimated Spending Authority

Department	FY2017	Out Years	Total
Finance	\$450,000.00	\$2,700,000.00	\$3,150,000.00

Amount of Funding:

\$3,150,000.00
General Fund (1000)

Contact Information:

Name	Department	Phone
Arif Rasheed, Deputy Director	Finance	(832) 393-9013
Gloria Moreno, Deputy Assistant Director	Finance	(832) 393-9005
Shannon Pleasant, Sr. Procurement Spec.	Finance	(832) 393-8741

ATTACHMENTS:

Description	Type
Ordinance 10.11.16	Signed Cover sheet
MWBE Modification Approval	Backup Material
MWBE Compliance Forms	Backup Material
Fair Campaign Ordinance - Form A	Backup Material
Fair Campaign Ordinance - Form B	Backup Material
Delinquent Tax Report	Backup Material
Department Recommendation Memo	Backup Material
Affidavit of Ownership	Backup Material
Funding Information	Financial Information
Budget Funding Information	Financial Information



Purchasing & Professional Services

STEP 1: PROVIDE SOLICITATION / PROJECT INFORMATION.

1. Date: 1/06/2016 2. Department: Finance 3. Solicitation #: S66-T25650
 4. Solicitation /Project Name: Sales/Use Tax Audit, analysis & reporting srv 6. Contract Value: \$2,365,000
 5. Description of Project: Perform audits to seek mis-allocated funds due to City; perform analysis & reporting to be used on economic reporting for the City

STEP 2: CALCULATE CONTRACT-SPECIFIC GOAL.

Please see Instructions for assistance with calculations.

A	B	C	D	E	F	G	H
Work Element Description	NAICS Code	Cost for Each Work Element	% Cost of Contract	# of MWBE Firms (B2G)	# of All Firms	MWBE Availability	Goal % for Work Element
Auditing Services	541211	\$ 2,365,000.00	100.00%	20	1047	1.91%	1.91%
Totals		\$ 2,365,000.00	100%				1.91%

STEP 3: PROVIDE GOAL CALCULATION INFORMATION FOR ITEMS # 7 - 10.

7. List method used to calculate # of All Firms in Column F: U.S. Census Bureau
 8. Calculated Contract-Specific Goal (Column H): 1.91%
 9. If contract goal should be more or less than calculated Contract-Specific Goal, please explain further goal adjustments:
Were able to attain 7.07% in existing contract .

10. List Proposed Contract Goal: MWBE 5%

STEP 4: SIGN AND DATE FORM.

[Signature]
Department Director / Designee

[Signature] Dep Dir 1-7-16
Signature Title Date

FOR OBO OFFICE USE ONLY:			
APPROVED:		DENIED:	
<u>[Signature]</u>	<u>1/7/16</u>		
OBO Assistant Director or Designee	Date	OBO Assistant Director or Designee	Date



CITY OF HOUSTON - CITY COUNCIL

Meeting Date: 10/25/2016

ALL

Item Creation Date: 8/30/2016

C73154-A4 Payment Processing Services - ORDINANCE

Agenda Item#: 31.

Summary:

ORDINANCE approving and authorizing fourth amendment to the Pay Connexion Service Terms Contract, as amended, between the City and **JPMORGAN CHASE BANK, N.A.** to provide for additional Credit Card Transaction Services for the Houston Permitting Center and the Houston Airport System

Background:

Approve an Ordinance Authorizing a Fourth Amendment to the Payment Processing Services - Pay Connexion Service Terms Contract, as Amended, Between the City of Houston and JPMorgan Chase Bank, N.A., to Extend the Contract Term From January 27, 2017 to October 3, 2018, and to provide for Additional Credit Card Transaction Services for the Houston Permitting Center of the Department of Public Works and Engineering and the Houston Airport System.

Specific Explanation:

The Chief Business Officer/Director of Finance and the Chief Procurement Officer recommend that City Council approve an ordinance authorizing a fourth amendment to the contract between the City of Houston and JPMorgan Chase Bank, N.A. to amend the Pay Connexion service terms to transfer payment of transaction fees (assessed by the card association and credit processor) for online payment processing services from JPMorgan Chase Bank, N.A. to the Houston Permitting Department of the Department of Public Works and Engineering and the Houston Airport System.

The original contract was awarded by Council on January 7, 2009, by Ordinance No. 2009-010 for three (3) years, with five one-year options. Ordinance No. 2009-433, Passed 5/27/2009, amended the contract to allow for citywide participation, to provide flexibility in the convenience fee schedule to accommodate the range in transaction amounts for other City departments, and to increase the maximum transaction amount. Ordinance No. 2010-690, Passed 9/1/2010, amended the contract to transfer the transaction fees assessed by the card association and credit processor to JPMorgan Chase Bank, N.A. in exchange for increased card processing business with the City.

The contract provides for online and point-of-sale payment processing capability to all City departments. Also, the vendor is required to supply point-of-sales terminal devices at no cost to the City. Under the terms of the original contract, all costs for online and point-of-sales payment services are paid for via convenience fees added on to the cost of the permit and paid by the citizen utilizing the service. Convenience fees vary, based on the price of the permit, from \$2.00 for

permits costing under \$50.00 to \$61.00 for permits ranging from \$2,000 to \$2,500.

John J. Gillespie, Chief Procurement Officer
Finance/Strategic Procurement Division

Department Approval Authority Signature

Prior Council Action:

Ordinance No. 2009-010, 1/7/2009

Ordinance No. 2009-433, 5/27/2009

Ordinance No. 2010-690, 9/1/2010

Amount of Funding:

Revenue Contract

Contact Information:

NAME:	DEPARTMENT/DIVISION	PHONE
Thy-Huyen Ruiz	FIN	(832) 393-9075
Brenda Chagoya, Division Manager	FIN/SPD	(832) 393-8723
Valerie Player-Kaufman, Sr. Procurement Specialist	FIN/SPD	(832) 393-8749

ATTACHMENTS:

Description

Signed Cover Sheet

Type

Signed Cover sheet

**CITY OF HOUSTON - CITY COUNCIL**

Meeting Date: 10/25/2016

ALL

Item Creation Date: 8/30/2016

C73154-A4 Payment Processing Services - ORDINANCE

Agenda Item#: 19.

Summary:

AN ORDINANCE APPROVING AND AUTHORIZING A FOURTH AMENDMENT TO THE PAY CONNEXION SERVICE TERMS CONTRACT, AS AMENDED, BETWEEN THE CITY AND JPMORGAN CHASE BANK, N.A. TO PROVIDE FOR ADDITIONAL CREDIT CARD TRANSACTION SERVICES FOR THE HOUSTON PERMITTING CENTER AND THE HOUSTON AIRPORT SYSTEM; CONTAINING PROVISIONS RELATING TO THE SUBJECT; AND DECLARING AN EMERGENCY

Background:

Approve an Ordinance Authorizing a Fourth Amendment to the Payment Processing Services - Pay Connexion Service Terms Contract, as Amended, Between the City of Houston and JPMorgan Chase Bank, N.A., to Extend the Contract Term From January 27, 2017 to October 3, 2018, and to provide for Additional Credit Card Transaction Services for the Houston Permitting Center of the Department of Public Works and Engineering and the Houston Airport System.

Specific Explanation:

The Chief Business Officer/Director of Finance and the Chief Procurement Officer recommend that City Council approve an ordinance authorizing a fourth amendment to the contract between the City of Houston and JPMorgan Chase Bank, N.A. to amend the Pay Connexion service terms to transfer payment of transaction fees (assessed by the card association and credit processor) for online payment processing services from JPMorgan Chase Bank, N.A. to the Houston Permitting Department of the Department of Public Works and Engineering and the Houston Airport System.

The original contract was awarded by Council on January 7, 2009, by Ordinance No. 2009-010 for three (3) years, with five one-year options. Ordinance No. 2009-433, Passed 5/27/2009, amended the contract to allow for citywide participation, to provide flexibility in the convenience fee schedule to accommodate the range in transaction amounts for other City departments, and to increase the maximum transaction amount. Ordinance No. 2010-690, Passed 9/1/2010, amended the contract to transfer the transaction fees assessed by the card association and credit processor to JPMorgan Chase Bank, N.A. in exchange for increased card processing business with the City.

The contract provides for online and point-of-sale payment processing capability to all City departments. Also, the vendor is required to supply point-of-sales terminal devices at no cost to the City. Under the terms of the original contract, all costs for online and point-of-sales payment services are paid for via convenience fees added on to the cost of the permit and paid by the citizen utilizing the service. Convenience fees vary, based on the price of the permit, from \$2.00 for permits costing under \$50.00 to \$61.00 for permits ranging from \$2,000 to \$2,500.

John J. Gillespie, Chief Procurement Officer
Finance/Strategic Procurement Division

Department Approval Authority Signature

Prior Council Action:

Ordinance No. 2009-010, 1/7/2009
Ordinance No. 2009-433, 5/27/2009
Ordinance No. 2010-690, 9/1/2010

Amount of Funding:

Revenue Contract

Contact Information:

NAME:	DEPARTMENT/DIVISION	PHONE
Thy-Huyen Ruiz	FIN	(832) 393-9075

Brenda Chagoya, Division Manager	FIN/SPD	(832) 393-8723
Valerie Player-Kaufman, Sr. Procurement Specialist	FIN/SPD	(832) 393-8749

ATTACHMENTS:

Description

Ordinance No. 2009-10
Ordinance No. 2009-433
Ordinance No. 2010-690
Form A - Fair Campaign Ordinance
Form B
Delinquent Tax Report
Certificate of Insurance
Ordinance 10.11.16

Type

Backup Material
Backup Material
Backup Material
Backup Material
Backup Material
Backup Material
Backup Material
Signed Cover sheet



CITY OF HOUSTON - CITY COUNCIL

Meeting Date: 10/25/2016

ALL

Item Creation Date:

L26011 – Interlocal Agreement for Analytical Laboratory
Testing Services - ORDINANCE

Agenda Item#: 32.

Summary:

ORDINANCE approving and authorizing Interlocal Agreement between the City and **DEPARTMENT OF STATE HEALTH SERVICES** for Analytical Laboratory Testing Services for the Public Works and Engineering Department (DSHS Contract No. 2017-049754-001); providing a maximum contract amount - \$152,400.00 - Enterprise Fund

Background:

S63-L26011 - Approve an Ordinance Authorizing an Interlocal Agreement for Analytical Laboratory Testing Services between the City of Houston and the Department of State Health Services for the Department of Public Works and Engineering.

SPECIFIC EXPLANATION:

The Director of the Department of Public Works and Engineering and the Chief Procurement Officer recommend that City Council approve an ordinance authorizing an Interlocal Agreement for analytical laboratory testing services between the City and the **Department of State Health Services** in an amount not to exceed **\$152,400.00** for a twenty one month term from **November 15, 2016 through August 31, 2018** for the Department of Public Works and Engineering. The contractor will be required to perform laboratory testing of the City's drinking water to ensure compliance with Federal, State and local regulations.

The Federal Safe Drinking Water Act, as amended in 1996, authorizes the Environmental Protection Agency (EPA) to develop and enforce rules and regulations that govern drinking water quality nationally. The EPA has authorized the Texas Commission on Environmental Quality (TCEQ) to administer the program in the State of Texas. The EPA and the TCEQ require that all public water systems be regularly monitored for compliance with established limits for approximately 90 regulated and up to 26 unregulated, chemical, physical, microbiological and radiological contaminants. Samples are collected from approximately 85 locations in the City of Houston's water system and analyzed either quarterly, annually, or tri-annually depending on the regulated contaminant and source of water. These certified analyses are reported to the TCEQ and the City of Houston. TCEQ, further reports to the EPA the compliance status of each system, based on these results.

The Department of State Health Services will continue testing the City's potable drinking water samples, including potable drinking water samples from other public water systems the City may

acquire during the term of this Agreement, using EPA methodology and any additional analyses required by EPA or TCEQ.

This recommendation is made pursuant to Chapter 791 of the Texas Local Government Code, entitled the Interlocal Cooperation Act for exempt procurement.

MWBE Subcontracting:

This procurement is exempt from MWBE subcontracting because the department is utilizing an Interlocal or Cooperative Purchasing Agreement for this purchase.

Hire Houston First:

This procurement is exempt from the City's Hire Houston First Ordinance. Bids/Proposals were not solicited because the department is utilizing an Interlocal or Cooperative Purchasing Agreement for this purchase

Pay or Play:

This procurement is exempt from the City's 'Pay or Play' Ordinance because the department is utilizing an Interlocal or Cooperative Purchasing Agreement for this purchase.

Fiscal Note:

Funding for this item is included in the FY 2017 Adopted Budget. Therefore, no Fiscal Note is required as stated in the Financial Policy Ord. 2014-1078.

John J. Gillespie, Chief Procurement Officer
Finance/Strategic Procurement Division

Department Approval Authority Signature

Prior Council Action:

Amount of Funding:

\$152,400.00 – Water & Sewer System Operating Fund (8300)

Contact Information:

NAME:	DEPARTMENT/DIVISION	PHONE
David Guernsey, Assistant Director	PWE	(832) 395-3640
Martin King, Division Manager	FIN/SPD	(832) 393-8705
Yesenia Chuca, Sr. Procurement Specialist	FIN/SPD	(832) 393-8727

ATTACHMENTS:

Description

RCA#L26011

Type

Signed Cover sheet



CITY OF HOUSTON - CITY COUNCIL

Meeting Date: 10/18/2016

ALL

Item Creation Date:

L26011 – Interlocal Agreement for Analytical Laboratory Testing Services - ORDINANCE

Agenda Item#: 16.

Summary:

Not Real Caption

Approve an Ordinance Authorizing an Interlocal Agreement for Analytical Laboratory Testing Services between the City of Houston and the Department of State Health Services for the Department of Public Works and Engineering.

Background:

S63-L26011 - Approve an Ordinance Authorizing an Interlocal Agreement for Analytical Laboratory Testing Services between the City of Houston and the Department of State Health Services for the Department of Public Works and Engineering.

SPECIFIC EXPLANATION:

The Director of the Department of Public Works and Engineering and the Chief Procurement Officer recommend that City Council approve an ordinance authorizing an Interlocal Agreement for analytical laboratory testing services between the City and the Department of State Health Services in an amount not to exceed \$152,400.00 for a twenty one month term from **November 15, 2016 through August 31, 2018** for the Department of Public Works and Engineering. The contractor will be required to perform laboratory testing of the City's drinking water to ensure compliance with Federal, State and local regulations.

The Federal Safe Drinking Water Act, as amended in 1996, authorizes the Environmental Protection Agency (EPA) to develop and enforce rules and regulations that govern drinking water quality nationally. The EPA has authorized the Texas Commission on Environmental Quality (TCEQ) to administer the program in the State of Texas. The EPA and the TCEQ require that all public water systems be regularly monitored for compliance with established limits for approximately 90 regulated and up to 26 unregulated, chemical, physical, microbiological and radiological contaminants. Samples are collected from approximately 85 locations in the City of Houston's water system and analyzed either quarterly, annually, or tri-annually depending on the regulated contaminant and source of water. These certified analyses are reported to the TCEQ and the City of Houston. TCEQ, further reports to the EPA the compliance status of each system, based on these results.

The Department of State Health Services will continue testing the City's potable drinking water samples, including potable drinking water samples from other public water systems the City may acquire during the term of this Agreement, using EPA methodology and any additional analyses required by EPA or TCEQ.

This recommendation is made pursuant to Chapter 791 of the Texas Local Government Code, entitled the Interlocal Cooperation Act for exempt procurement.

MWBE Subcontracting:

This procurement is exempt from M/WBE subcontracting because the department is utilizing an Interlocal or Cooperative Purchasing Agreement for this purchase.

Hire Houston First:

This procurement is exempt from the City's Hire Houston First Ordinance. Bids/Proposals were not solicited because the department is utilizing an Interlocal or Cooperative Purchasing Agreement for this purchase

Pay or Play:

This procurement is exempt from the City's 'Pay or Play' Ordinance because the department is utilizing an Interlocal or Cooperative Purchasing Agreement for this purchase.

Fiscal Note:

Funding for this item is included in the FY 2017 Adopted Budget. Therefore, no Fiscal Note is required as stated in the Financial Policy Ord. 2014-1078.

John J. Gillespie, Chief Procurement Officer
Finance/Strategic Procurement Division

Department Approval Authority Signature

Prior Council Action:

Amount of Funding:

\$152,400.00 – Water & Sewer System Operating Fund (8300)

Contact Information:

NAME:	DEPARTMENT/DIVISION	PHONE
David Guernsey, Assistant Director	PWE	(832) 395-3640
Martin King, Division Manager	FIN/SPD	(832) 393-8705
Yesenia Chuca, Sr. Procurement Specialist	FIN/SPD	(832) 393-8727

ATTACHMENTS:

Description

Type

Funding Information - Table A

Backup Material

Contract - DSHS

Backup Material



CITY OF HOUSTON - CITY COUNCIL

Meeting Date: 10/25/2016

District B, District C, District D, District H, District I, District J

Item Creation Date: 9/23/2016

25MSCL122 - Houston Harris Division Patrol

Agenda Item#: 33.

Summary:

ORDINANCE approving payment of \$13,356.88 to **HOUSTON HARRIS DIVISION PATROL, INC** for Emergency Armed Security Guard Services for various Houston Health Departments and Solid Waste Management Departments - General Fund - **DISTRICTS B - DAVIS; C - COHEN; D - BOYKINS; H - CISNEROS; I - GALLEGOS and J - LASTER**

Background:

The General Services Department (GSD) recommends that City Council approve payment to Houston Harris Division Patrol Inc. in the amount of \$13,356.88 for armed security guard services provided at the locations listed below for the Houston Health (HHD) and Solid Waste Management (SWMD) Departments. This Council action is necessary because the prior FY2016 expenditures to date of \$46,188.70 will exceed the \$50,000.00 threshold limit for Council approval. In October and January of FY 2016, GSD received requests for armed security guards from HHD and SWMD, respectively. The requests stemmed from concerns over the new open carry law and its impact in various HHD facilities, as well as health and safety issues surrounding the fatal shooting of a City employee at a SWMD facility. At the time of the requests, the City's current security guard services contract was being finalized. Therefore, GSD utilized an open purchase order with Houston Harris Division Patrol Inc., to provide the requested services.

Dept	Facility	Address	Key MAP	District
HHD	Fifth Ward Multi-Service Center	4014 Market Street	494E	B
HHD	Northside Health Center	8523 Arkansas	454E	H
HHD	West End Health Center	190 Heights Blvd	493E	C
HHD	La Nueva Casa De Amigos Health	1809 Main	493G	H
HHD	West End Multi-Service Center	170 Heights Boulevard #138	493E	C
HHD	Kashmere Multi-Service Center	4802 Lockwood Drive #115	454U	B
HHD	Denver Harbor Multi-Service Center	6402 Market Street	494E	B
HHD	John Peavy Senior Center	3814 Market Street	494F	B
HHD	Northeast Multi-Service Center	9720 Spaulding, Bldg # 4	455C	B

HHD	Cochran Building	1500 Cochran	493D	H
HHD	Acres Homes Multi-Service Center	6719 W. Montgomery	412Y	B
SWMD	Charles Idlebird Service Center	1502 Central Street	535G	I
SWMD	Environmental Center	11500 S Post Oak Rd	572C	D
SWMD	Buck Buchanan Service Center	1245 Judway Street	452N	C
SWMD	Solid Waste Management Service Center	5614 Neches Street	454U	H
SWMD	Southwest Neighborhood Depository/Recycling Center	10785 Southwest Freeway	529Z	J
SWMD	Solid Waste Management Service Center	11538 S Post Oak Rd	571C	K

Amount of Funding:

\$ 13,356.88 – General Fund (1000)

Contact Information:

Jacquelyn L. Nisby

Phone: (832) 393-8023



ATTACHMENTS:

Description

Houston Harris Division Patrol RCA
Houston Harris Division Patrol Maps

Type

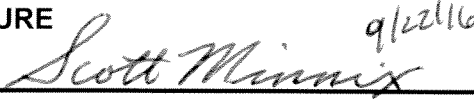
Signed Cover sheet
Signed Cover sheet

SUBJECT: Approve Payment to Houston Harris Division Patrol Inc. for Emergency Armed Security Guard Services for Various Departments		Page 1 of 2	Agenda Item
FROM (Department or other point of origin): General Services Department		Origination Date	Agenda Date
DIRECTOR'S SIGNATURE Scott Minnix <i>9/22/16</i> 		Council District(s) affected: B, C, D, H, I and J	
For additional information contact: Jacquelyn L. Nisby <i>JLN</i> Phone: (832) 393-8023		Date and identification of prior authorizing Council action:	
RECOMMENDATION: Approve payment to Houston Harris Division Patrol Inc. in the amount of \$13,356.88 for emergency armed security guard services for various departments.			
Amount and Source Of Funding: \$ 13,356.88 – General Fund (1000)		Finance Budget:	
<p>SPECIFIC EXPLANATION: The General Services Department (GSD) recommends that City Council approve payment to Houston Harris Division Patrol Inc. in the amount of \$13,356.88 for armed security guard services provided at the locations listed below for the Houston Health (HHD) and Solid Waste Management (SWMD) Departments. This Council action is necessary because the prior FY2016 expenditures to date of \$46,188.70 will exceed the \$50,000.00 threshold limit for Council approval.</p> <p>In October and January of FY 2016, GSD received requests for armed security guards from HHD and SWMD, respectively. The requests stemmed from concerns over the new open carry law and its impact in various HHD facilities, as well as health and safety issues surrounding the fatal shooting of a City employee at a SWMD facility. At the time of the requests, the City's current security guard services contract was being finalized. Therefore, GSD utilized an open purchase order with Houston Harris Division Patrol Inc., to provide the requested services.</p>			
REQUIRED AUTHORIZATION			CUIC ID # 25MSCL122
General Services Department:  Humberto Bautista, P.E. Chief of Operations Property Management Division	Houston Health Department: Stephen L. Williams, M.Ed., MPA Director	Solid Waste Management Department: Harry Hayes Director	

Date:	Subject: Approve Payment to Houston Harris Division Patrol Inc. for Emergency Armed Security Guard Services for Various Departments	Originator's Initials EA	Page 2 of 2
--------------	--	------------------------------------	-----------------------

PROJECT LOCATIONS:

Dept	Facility	Address	Key MAP	District
HHD	Fifth Ward Multi-Service Center	4014 Market Street	494E	B
HHD	Northside Health Center	8523 Arkansas	454E	H
HHD	West End Health Center	190 Heights Blvd	493E	C
HHD	La Nueva Casa De Amigos Health	1809 Main	493G	H
HHD	West End Multi-Service Center	170 Heights Boulevard #138	493E	C
HHD	Kashmere Multi-Service Center	4802 Lockwood Drive #115	454U	B
HHD	Denver Harbor Multi-Service Center	6402 Market Street	494E	B
HHD	John Peavy Senior Center	3814 Market Street	494F	B
HHD	Northeast Multi-Service Center	9720 Spaulding, Bldg # 4	455C	B
HHD	Cochran Building	1906 Cochran	493D	H
HHD	Acres Homes Multi-Service Center	6719 W. Montgomery	412Y	B
SWMD	Charles Idlebird Service Center	1502 Central Street	535G	I
SWMD	Environmental Center	11500 S Post Oak Rd	572C	D
SWMD	Buck Buchanan Service Center	1245 Judiway Street	452N	C
SWMD	Solid Waste Management Service Center	5614 Neches Street	454U	H
SWMD	Southwest Neighborhood Depository/Recycling Center	10785 Southwest Freeway	529Z	J
SWMD	Solid Waste Management Service Center	11538 S Post Oak Rd	571C	K

CITY OF HOUSTON
HARRIS COUNTY, TEXAS

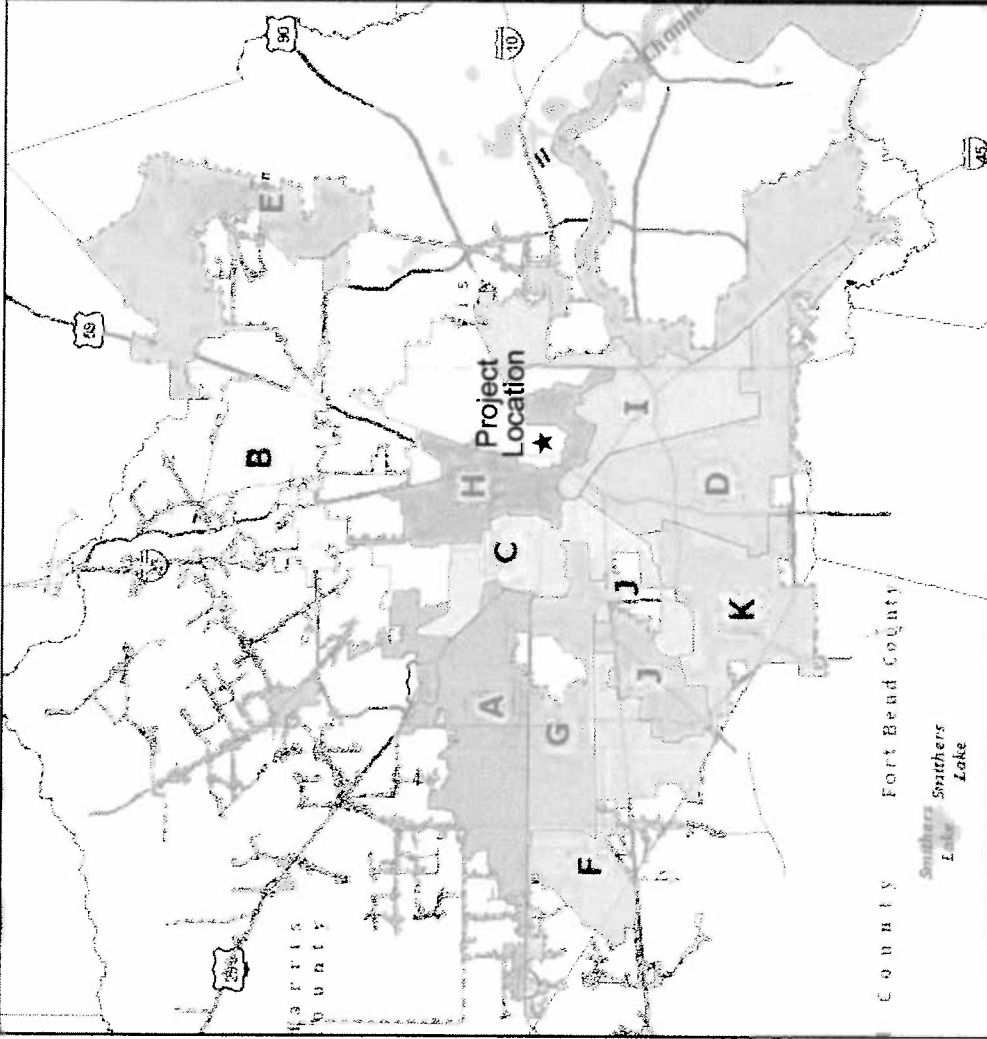

FIFTH WARD MULTI-SERVICE CENTER
4014 MARKET ST.
HOUSTON, TX 77020

COUNCIL DISTRICT "B"

KEY MAP NO. 494E

CITY OF HOUSTON
HARRIS COUNTY, TEXAS

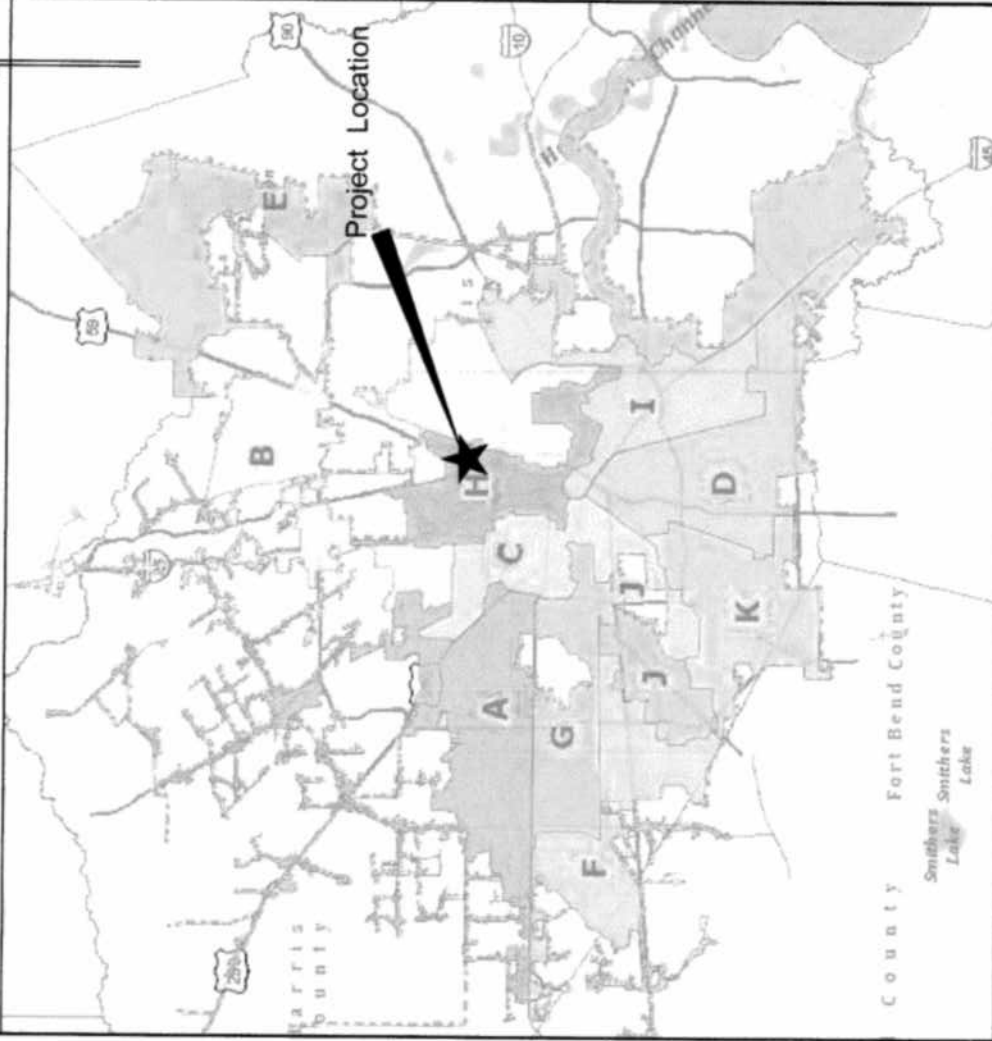

Northside Health Center
8523 Arkansas St.
Houston, TX 77093

COUNCIL DISTRICT "H"

KEYMAP No. 454E

CITY OF HOUSTON
HARRIS COUNTY, TEXAS

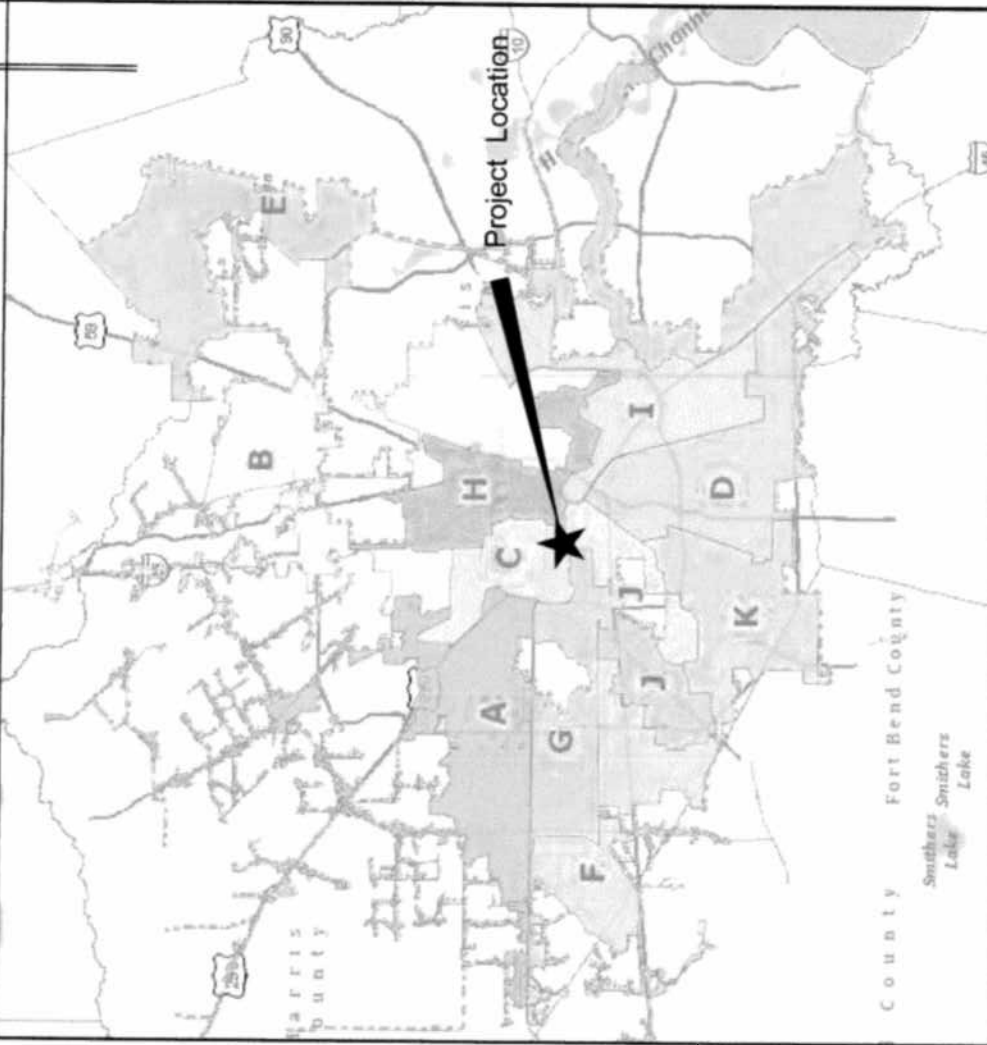

West End Health Center
190 Heights Blvd.
Houston, TX 77007

COUNCIL DISTRICT "C"

KEYMAP No. 493E

CITY OF HOUSTON
HARRIS COUNTY, TEXAS

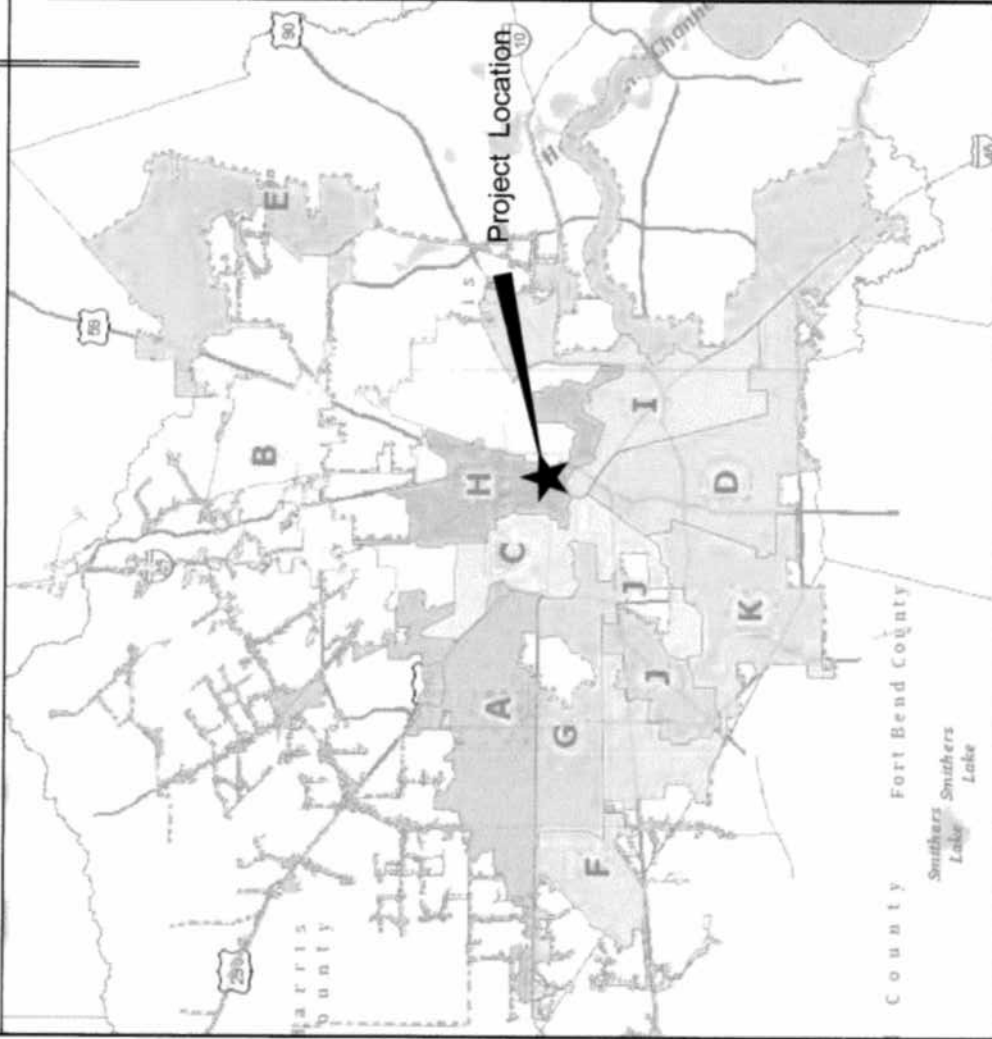

La Nueva Casa De Amigos Health Center
1809 N. Main
Houston, TX 77030

COUNCIL DISTRICT "H"

KEY MAP NO. 493G

CITY OF HOUSTON
HARRIS COUNTY, TEXAS

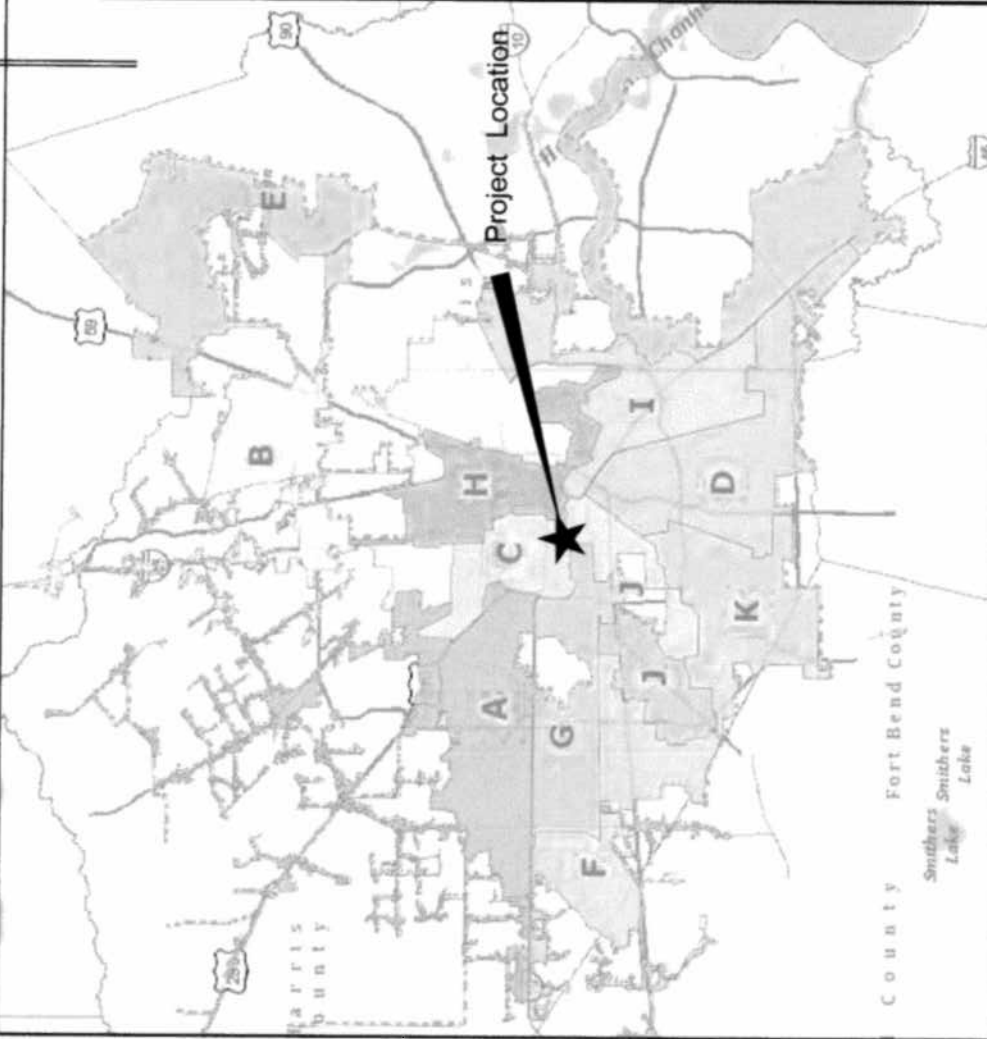

West End Multi-Service Center
170 Heights Blvd. #138
Houston, TX 77007

COUNCIL DISTRICT "C"

KEYMAP No. 493E

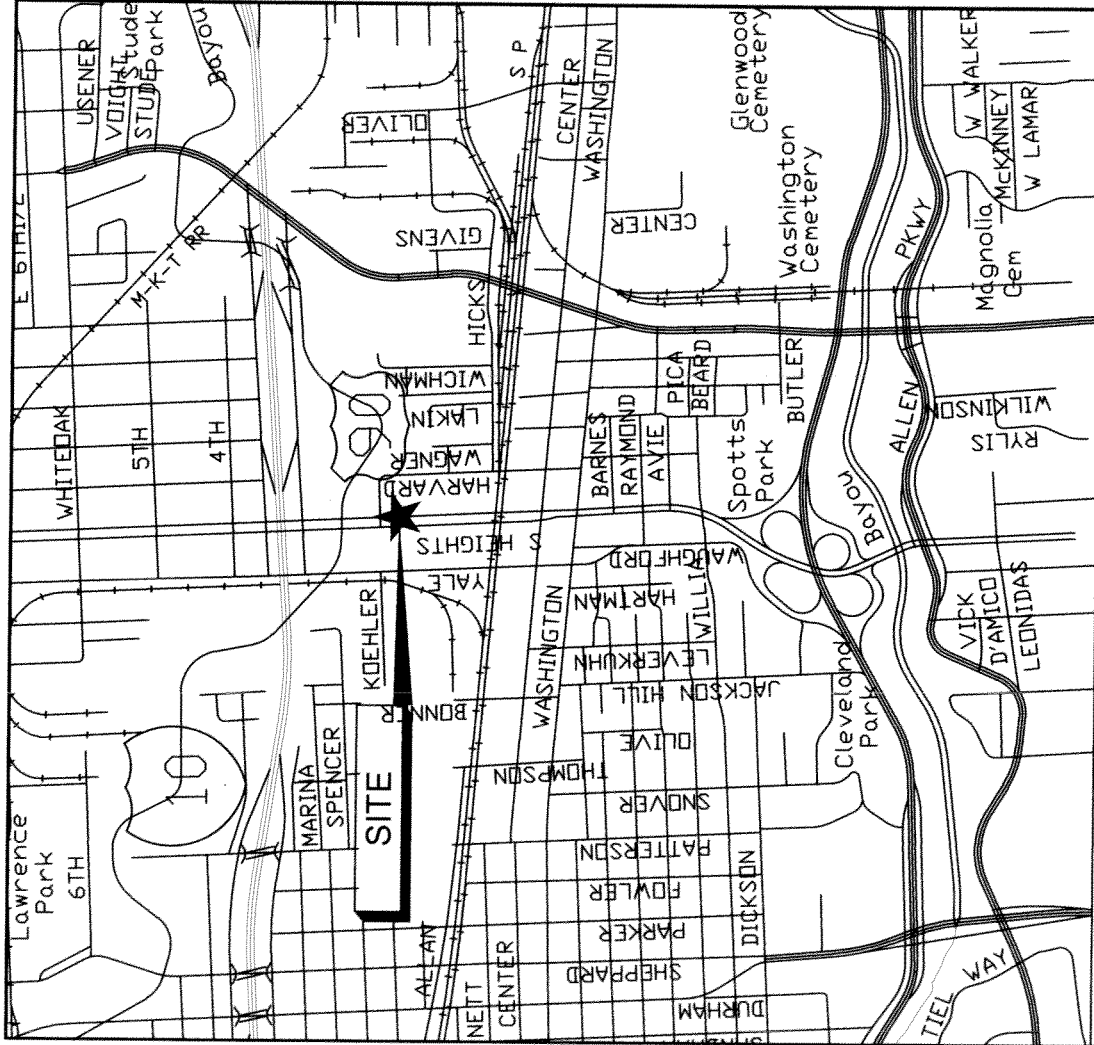

West End Multi-Service Center
 170 Heights Blvd. #138
 Houston, TX 77007

COUNCIL DISTRICT "C"

KEYMAP No. 493E

CITY OF HOUSTON
HARRIS COUNTY, TEXAS

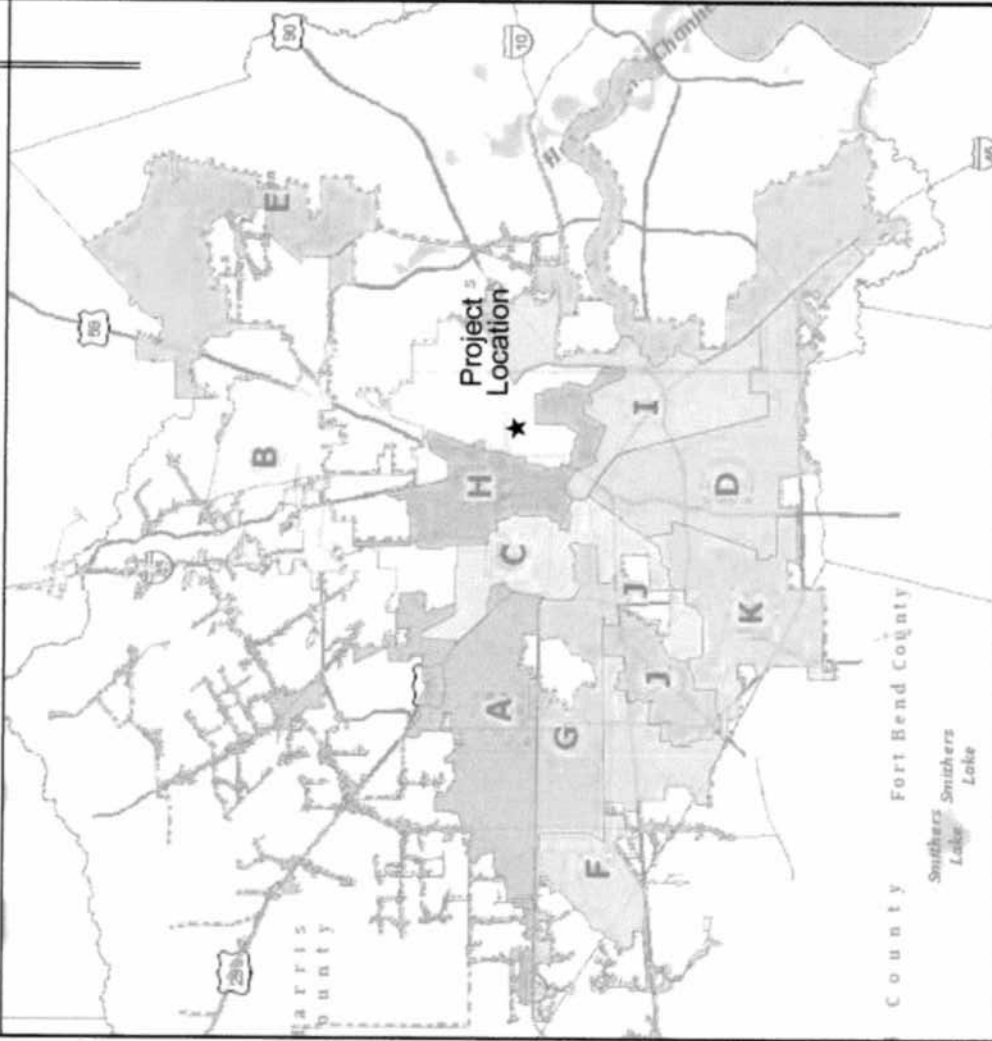

Kashmere Multi-Service Center
4802 Lockwood Dr. #115
Houston, TX 77026

COUNCIL DISTRICT "B"

KEYMAP No. 454U

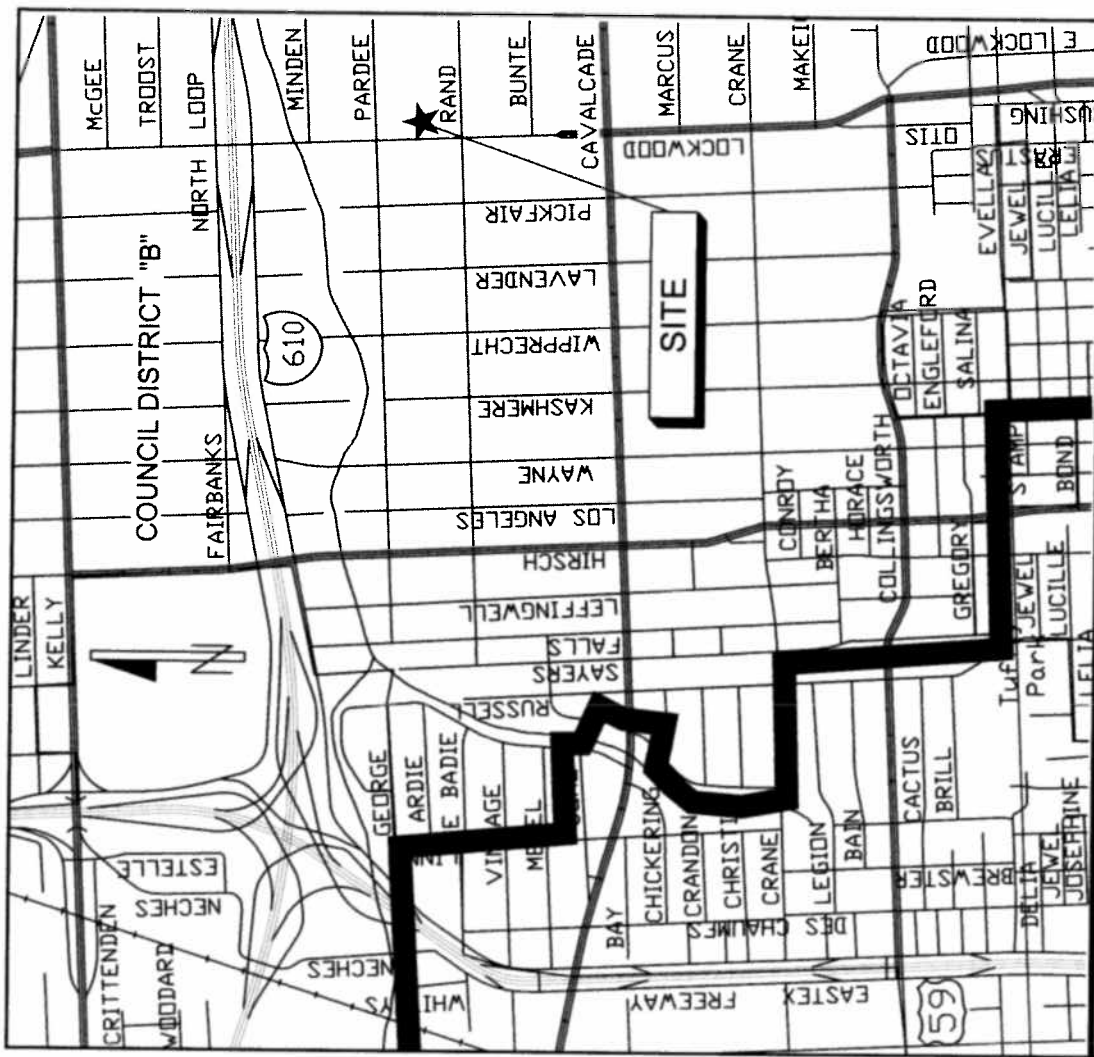

Kashmere Multi-Service Center
4802 Lockwood Dr. #115
Houston, TX 77026

COUNCIL DISTRICT "B"

KEYMAP No. 454U

CITY OF HOUSTON
HARRIS COUNTY, TEXAS

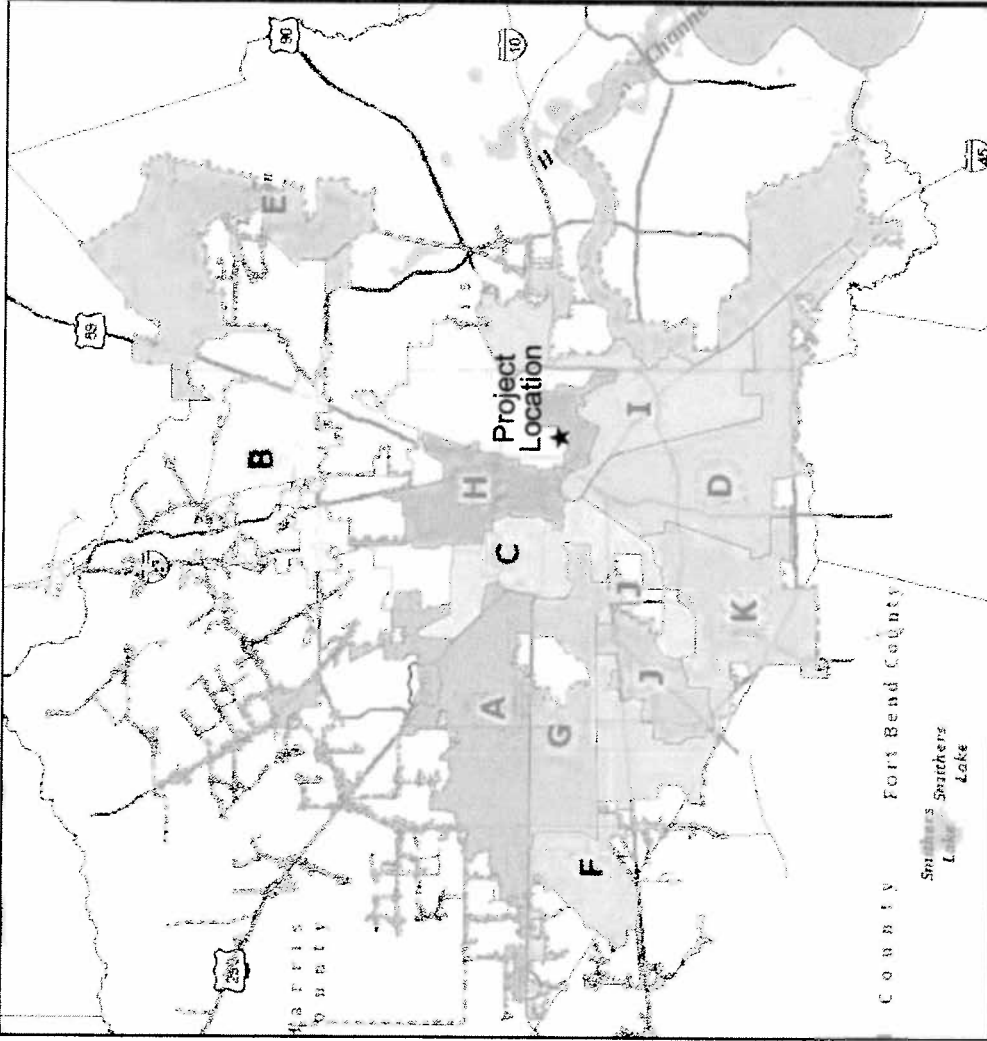

Denver Harbor Multi-Service Center
6402 Market St.
Houston, TX 77020

COUNCIL DISTRICT "B"

KEY MAP NO. 494E

CITY OF HOUSTON
HARRIS COUNTY, TEXAS

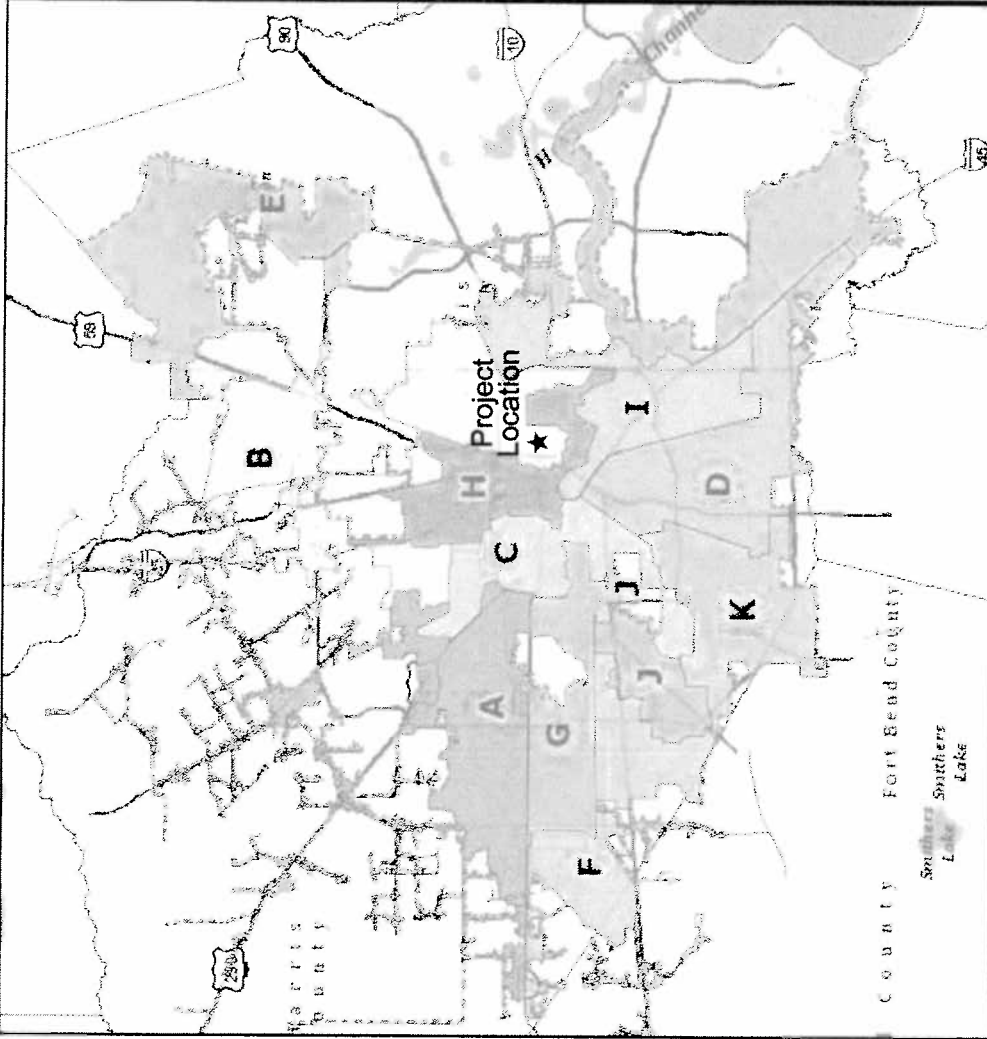

John Peavy Senior Center
3814 Market St.
Houston, TX 77020

COUNCIL DISTRICT "B"

KEY MAP NO. 494F

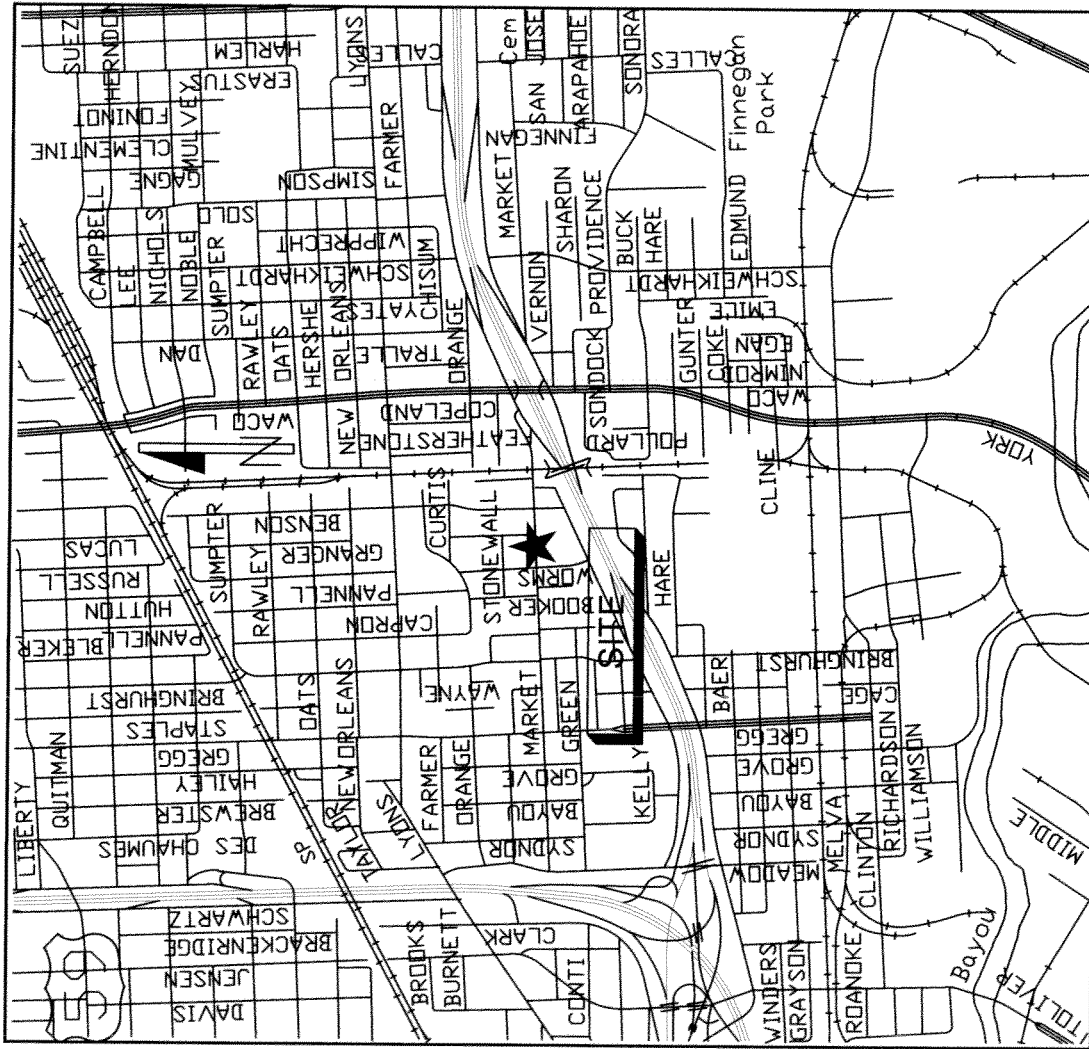

John Peavy Senior Center
 3814 Market St.
 Houston, TX 77020

COUNCIL DISTRICT "B"

KEY MAP NO. 494F

CITY OF HOUSTON
HARRIS COUNTY, TEXAS

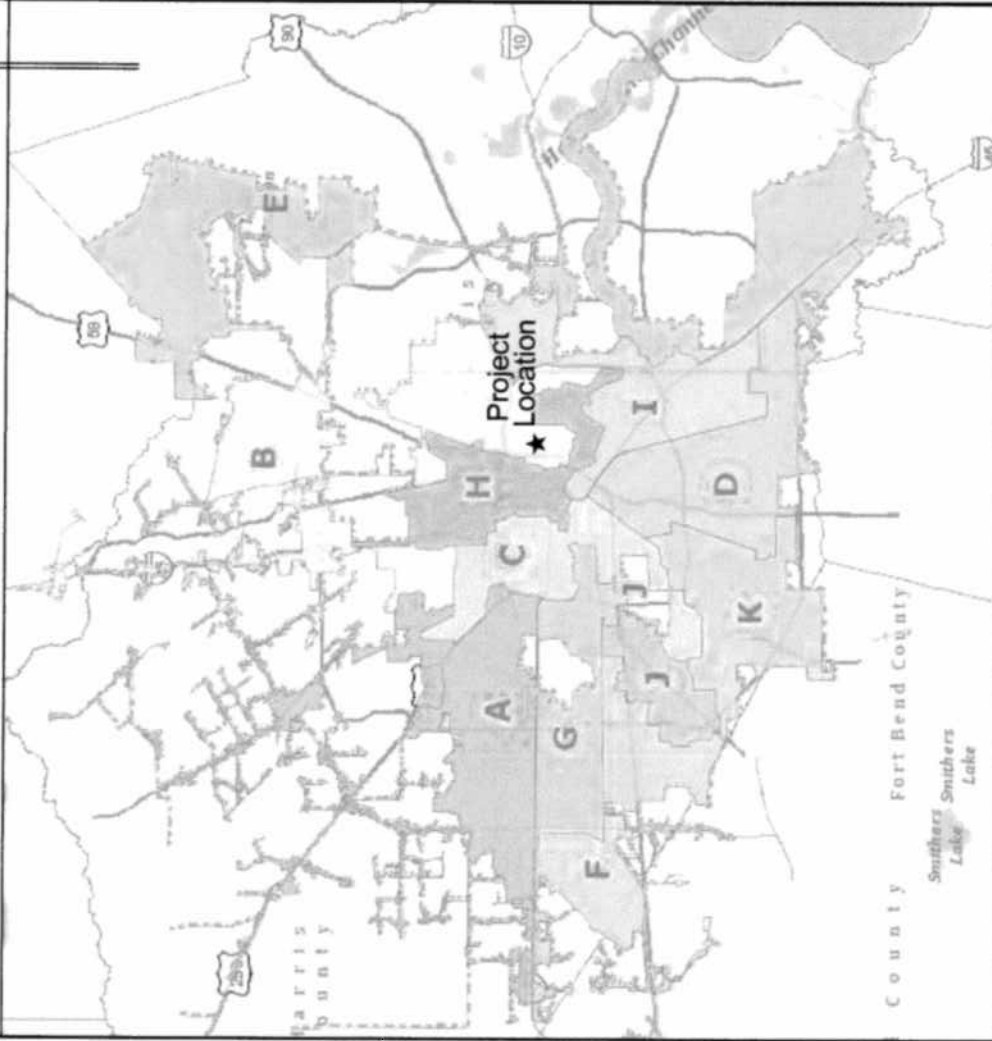

Northeast Multi-Service Center
9720 Spaulding Building #4
Houston, TX 77016

COUNCIL DISTRICT "B"

KEY MAP NO. 455C

CITY OF HOUSTON
HARRIS COUNTY, TEXAS

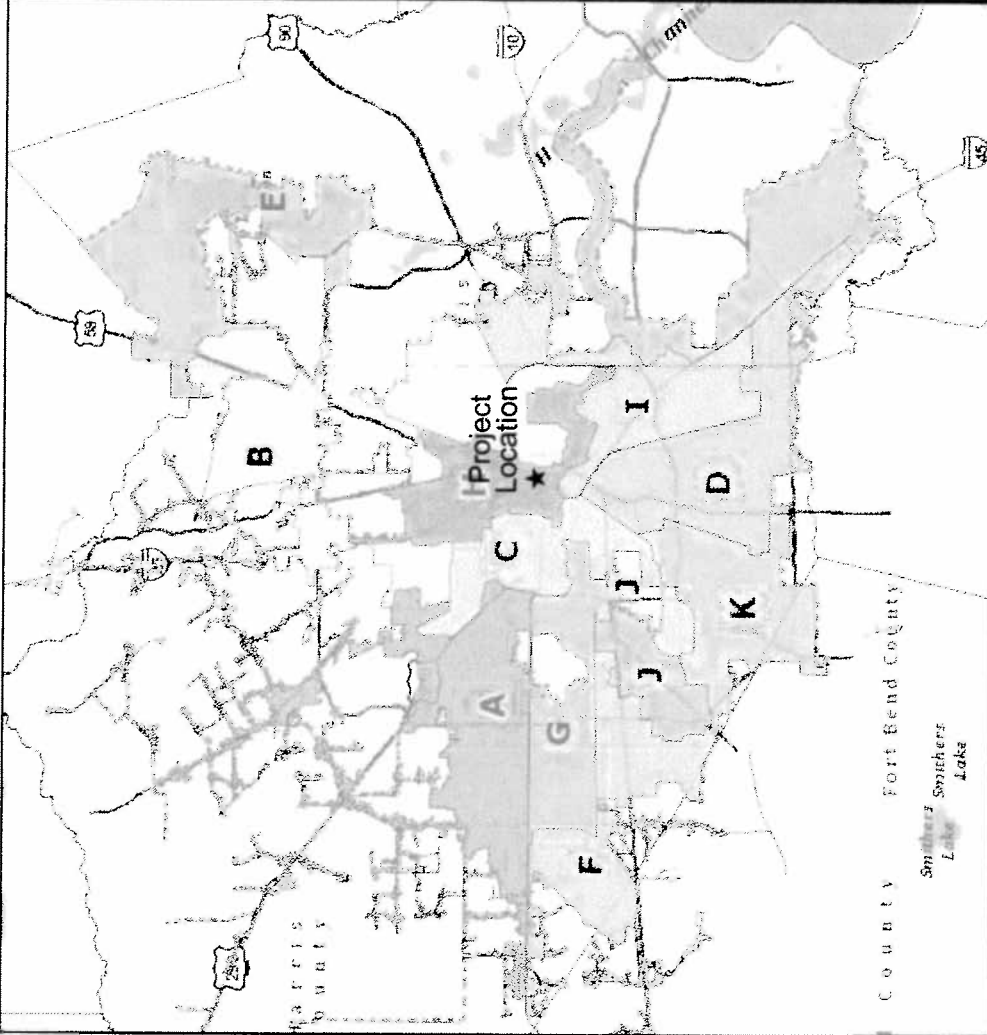

Cochran Building
1906 Cochran
Houston, TX 77009

COUNCIL DISTRICT "H"

KEY MAP NO. 493D

CITY OF HOUSTON
HARRIS COUNTY, TEXAS

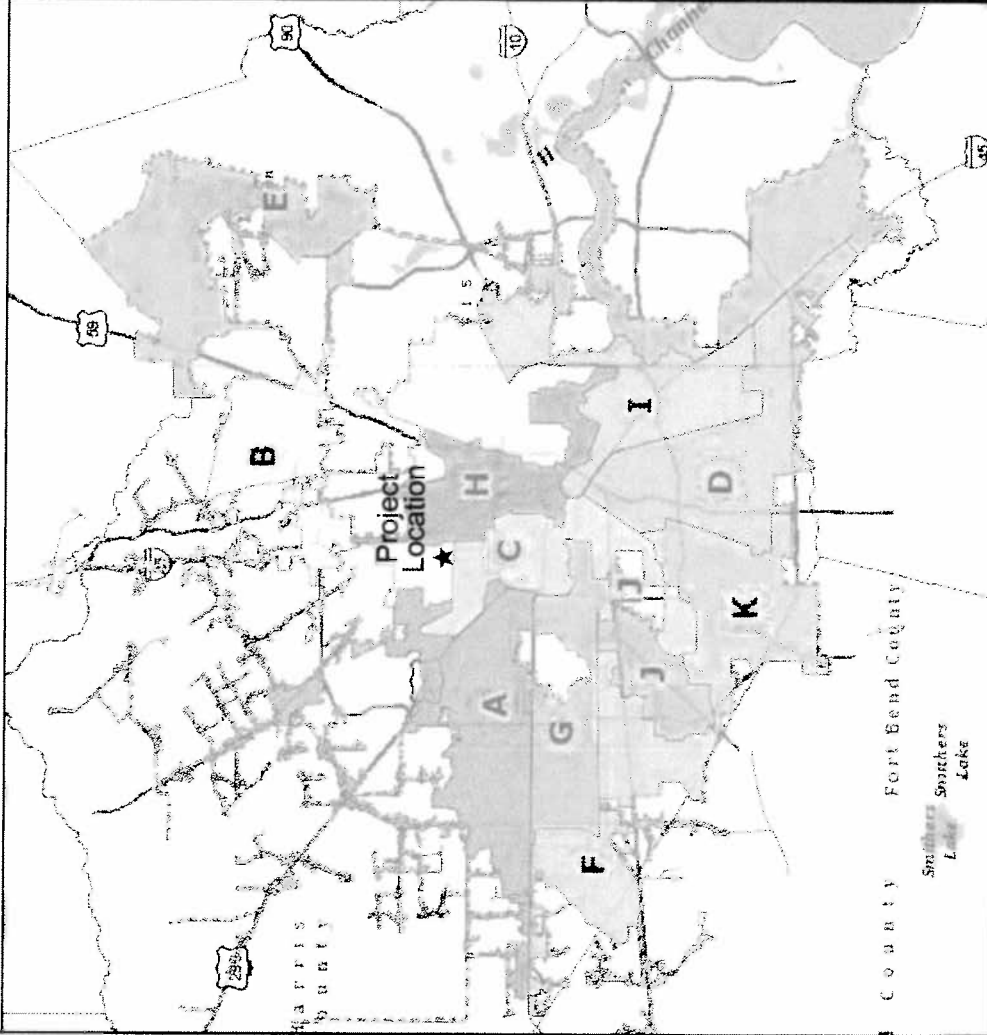

Acres Homes Multi-Service Center
6719 W Montgomery
Houston, TX 77091

COUNCIL DISTRICT "B"

KEYMAP No. 412Y

CITY OF HOUSTON
HARRIS COUNTY, TEXAS

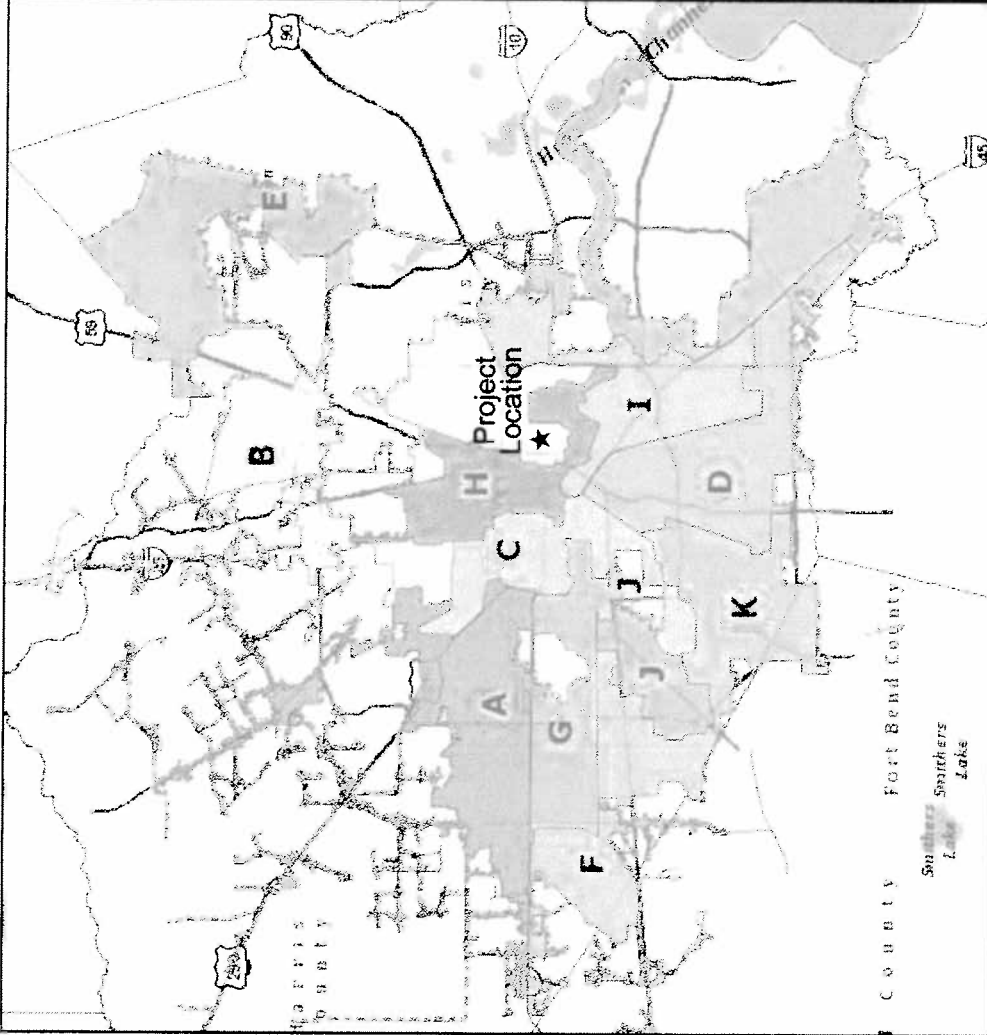

Charles Idlebird Service Center
1502 Central St.
Houston, TX 77012

COUNCIL DISTRICT "I"

KEYMAP No. 535G

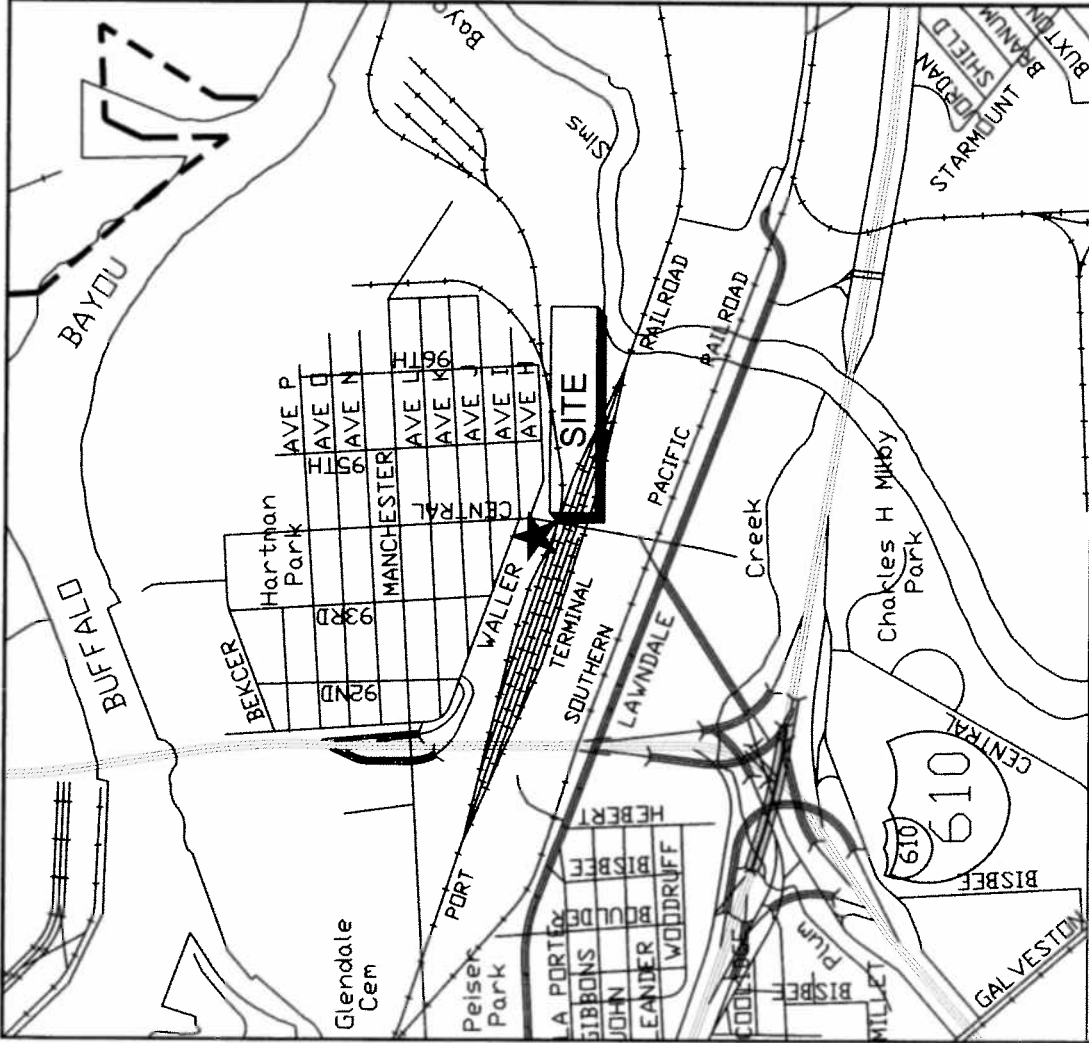

Charles Idlebird Service Center
 1502 Central St.
 Houston, TX 77012

COUNCIL DISTRICT "I"

KEYMAP No. 535G

CITY OF HOUSTON
HARRIS COUNTY, TEXAS

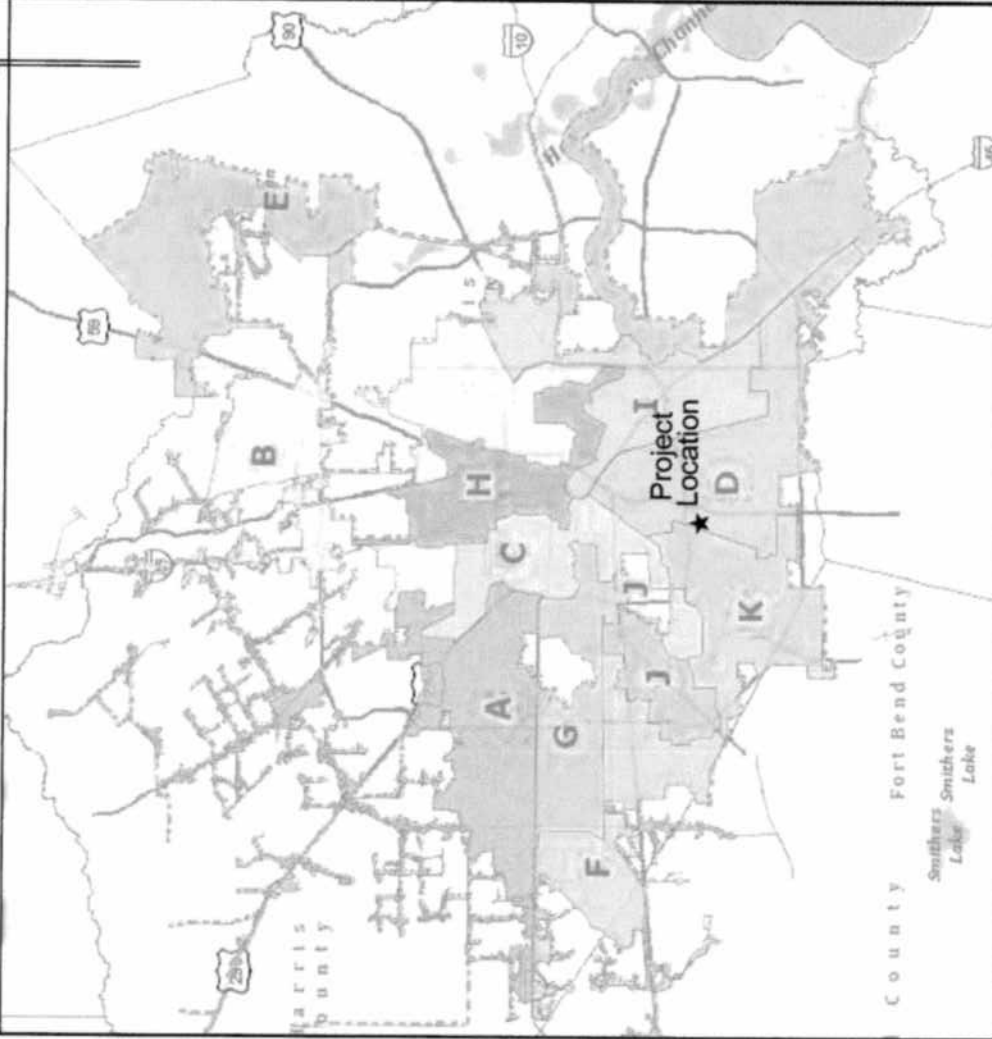

Environmental Center
11500 S Post Oak Rd.
Houston, TX 77035

COUNCIL DISTRICT "D"

KEY MAP NO. 572C

CITY OF HOUSTON
HARRIS COUNTY, TEXAS

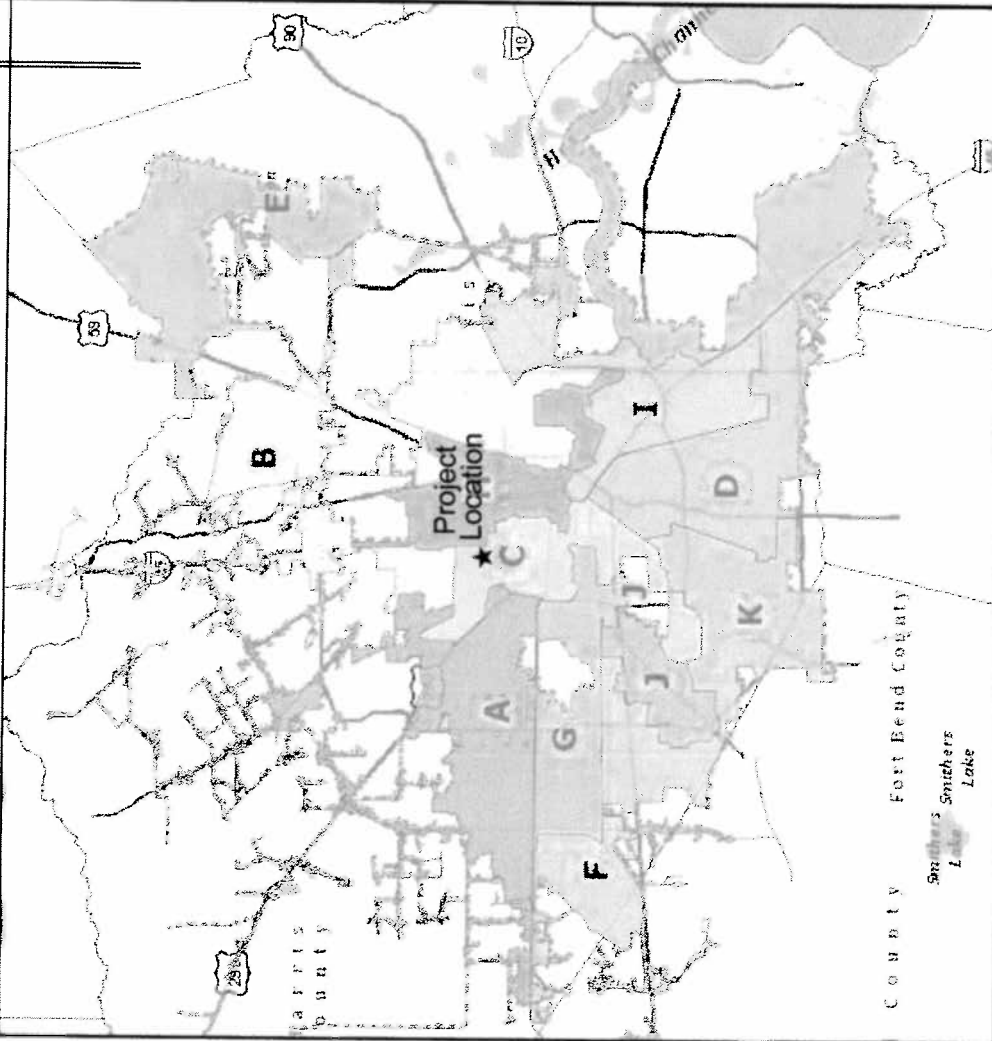

Buck Buchanan Service Center
1245 Judiway St.
Houston, TX 77018

COUNCIL DISTRICT "C"

KEY MAP NO. 452N

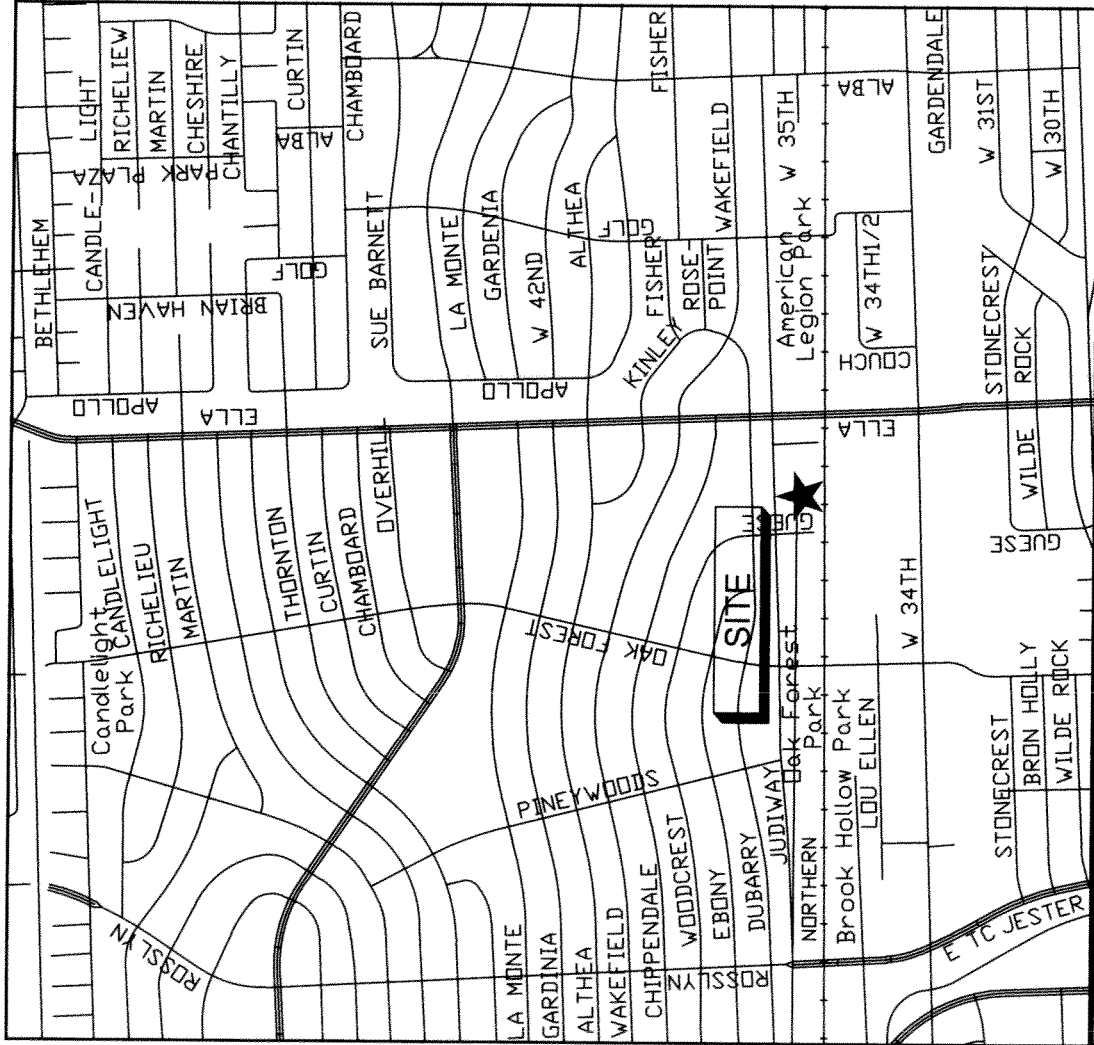

Buck Buchanan Service Center
 1245 Judiway St.
 Houston, TX 77018

COUNCIL DISTRICT "C"

KEY MAP NO. 452N

CITY OF HOUSTON
HARRIS COUNTY, TEXAS

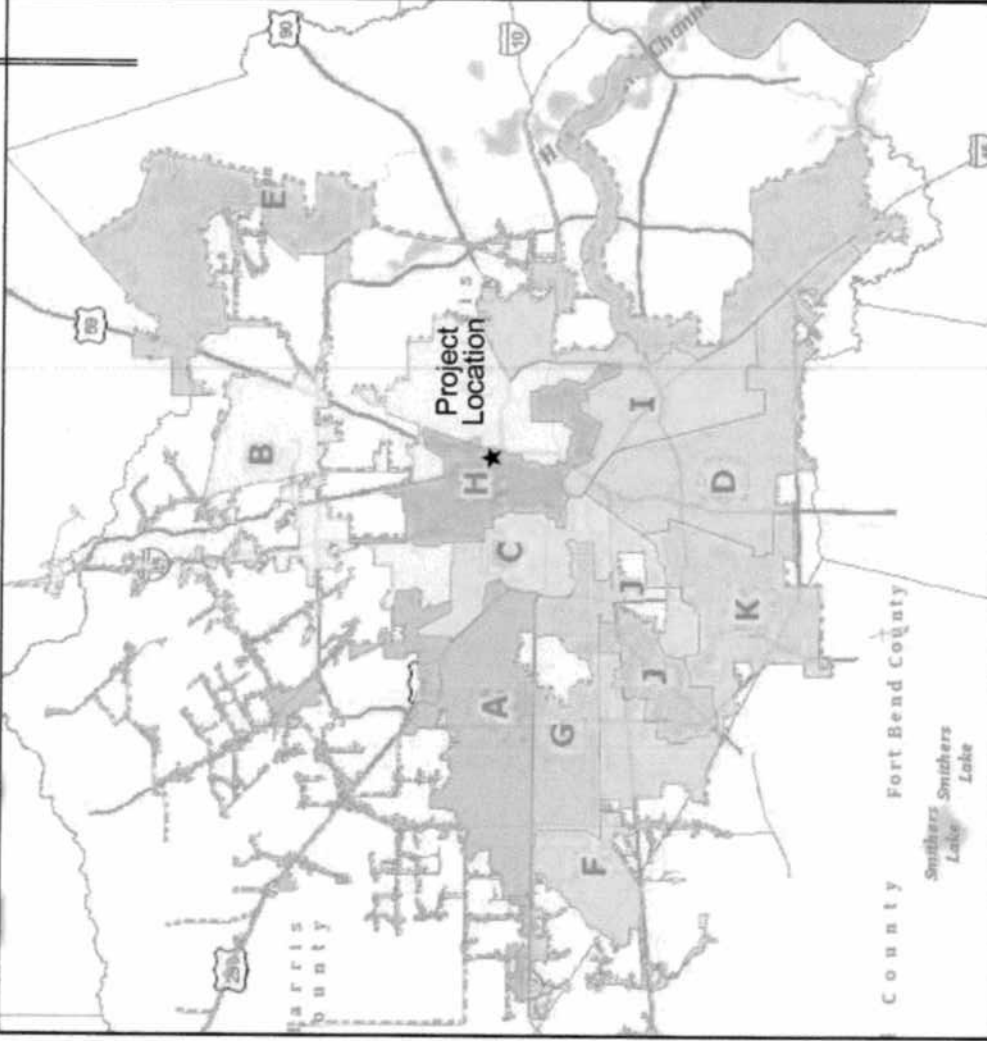

Solid Waste Management Multi-Servie Center
5614 Neches St.
Houston, TX 77026

COUNCIL DISTRICT "H"

KEYMAP No. 454U

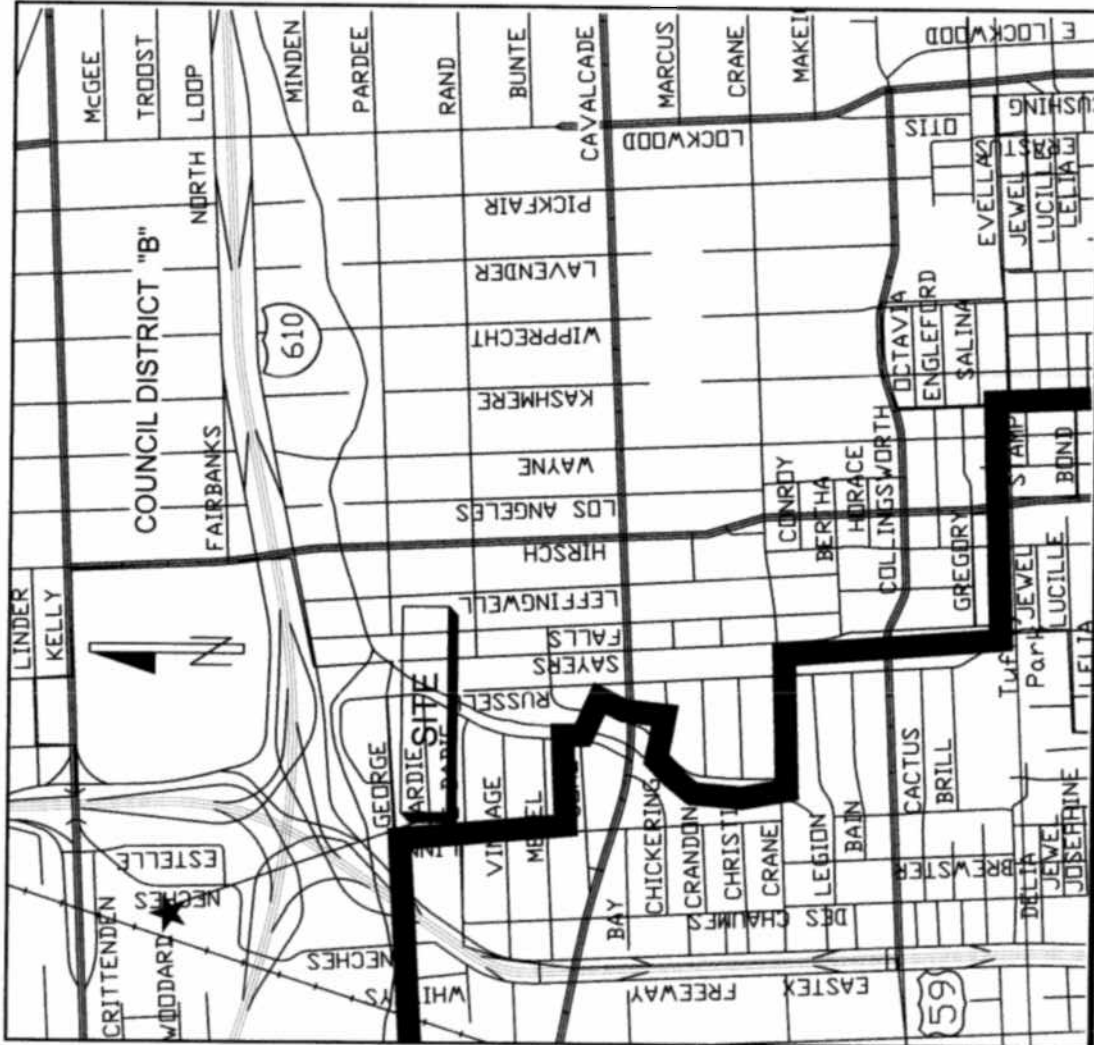

Solid Waste Management Multi-Servie Center
5614 Neches St.
Houston, TX 77026

COUNCIL DISTRICT "H"

KEYMAP No. 454U

CITY OF HOUSTON
HARRIS COUNTY, TEXAS

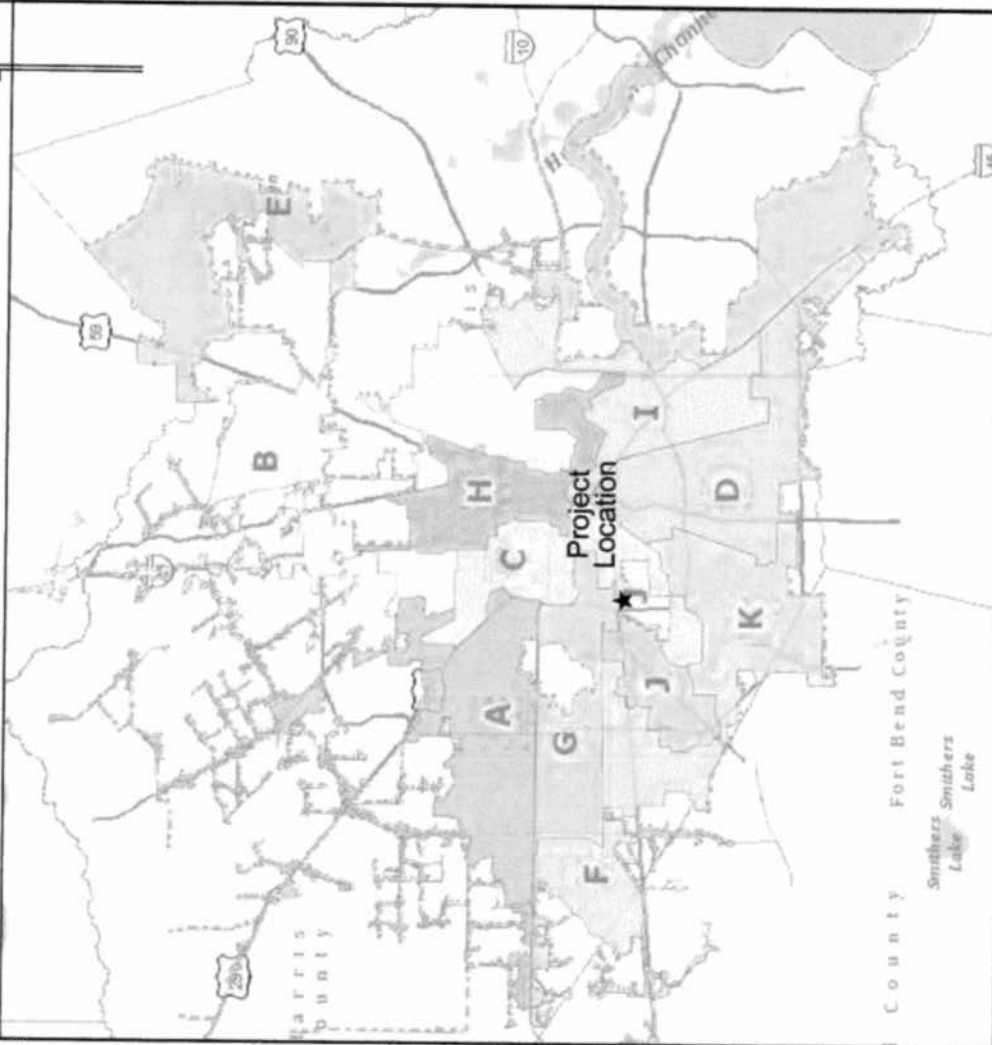

Southwest Neighborhood Depository/Recycling Center

10785 SOUTHWEST FWY

HOUSTON, TX 77074

COUNCIL DISTRICT "J"

KEY MAP NO. 529Z

CITY OF HOUSTON
HARRIS COUNTY, TEXAS

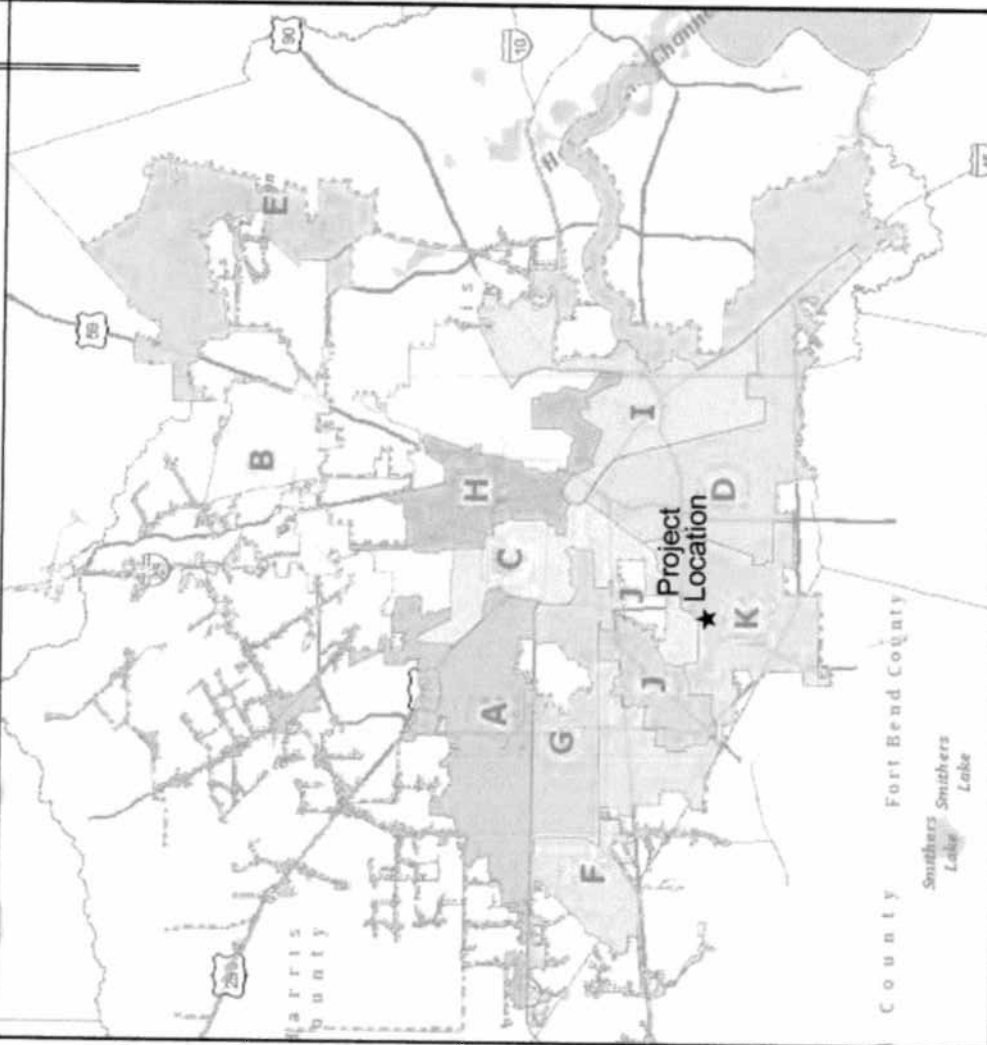

Solid Waste Management Service Center

11538 South Post Oak
Houston, TX 77035

COUNCIL DISTRICT "K"

KEY MAP NO. 571C



Solid Waste Management Service Center

11538 South Post Oak
Houston, TX 77035

COUNCIL DISTRICT "K"

KEY MAP NO. 571C



CITY OF HOUSTON - CITY COUNCIL

Meeting Date: 10/25/2016

ALL

Item Creation Date: 9/29/2016

25GM320 - Professional Materials Testing Services

Agenda Item#: 34.

Summary:

ORDINANCE approving and authorizing Professional Materials Engineering and Testing Services Laboratory Contracts between the City of Houston and (1) **AUSTIN-REED ENGINEERS, LLC**, (2) **KLEINFELDER, INC**, (3) **RABA- KISTNER, INC**, (4) **ALL-TERRA ENGINEERING, INC**, (5) **ASSOCIATED TESTING LABORATORIES, INC**, (6) **PROFESSIONAL SERVICES INDUSTRIES, INC**, (7) **GEOTECH ENGINEERING AND TESTING, INC**, (8) **ECS TEXAS, LLP**, (9) **ALPHA TESTING, INC**, (10) **QC LABORATORIES, INC**, (11) **GORRONDONA ENGINEERING SERVICES, INC**, (12) **KENALL, INC**, (13) **GEOTEST ENGINEERING, INC**, respectively

Background:

SPECIFIC EXPLANATION: The General Services Department (GSD) recommends that City Council approve 13 professional materials engineering and testing services laboratory contracts with the firms listed below to provide materials testing services to support the construction of Capital Improvement Plan projects managed by GSD. The contracts will be funded at the time of the construction award. Each initial contract term is three-years with a one-year renewal option.

On March 25, 2016, GSD advertised a Request for Qualifications (RFQ) for materials engineering and testing services for GSD managed construction projects. The RFQ contained selection criteria that ranked respondents on experience and expertise of the contractor and its individual members, technical approach, and quality assurance program. The Statements of Qualifications were due on April 14, 2016 and 13 firms responded. GSD evaluated the respondents and determined that all 13 firms are licensed and have the professional qualifications, experience, and technical approach to perform the services.

*Austin-Reed Engineers, LLC

Kleinfelder, Inc.

Raba-Kistner, Inc.

*All-Terra Engineering, Inc

*Associated Testing Laboratories, Inc.

Professional Services Industries, Inc.

*Geotech Engineering and Testing, Inc.

ECS Texas, LLP

Alpha Testing, Inc.

QC Laboratories, Inc.

*Gorrondona Engineering Services, Inc.

*Kenall, Inc.

*Geotest Engineering, Inc.

* M/W/SBE firms

PROJECT LOCATIONS: Citywide

SCOPE OF CONTRACT AND FEE: Under the terms of the contract, the firms will be assigned to various projects during the construction phase and will perform materials testing to assure quality control during construction and compliance with engineering design specifications. The specific engineering tests and analysis to be performed will be identified in the respective construction contracts.

Amount of Funding:

Contact Information:

Jacquelyn Nisby 832 393-8024

ATTACHMENTS:

Description

Type

Professional Materials Testing Services - RCA Signed Cover sheet

TO: Mayor via City Secretary

REQUEST FOR COUNCIL ACTION

SUBJECT: Professional Materials Engineering and Testing Services Laboratory Contracts		Page 1 of 2	Agenda Item														
FROM (Department or other point of origin): General Services Department		Origination Date	Agenda Date														
DIRECTOR'S SIGNATURE: Scott Minnix <i>8/25/16</i> 		Council Districts affected: All															
For additional information contact: Jacquelyn L. Nisby <i>JLN</i> Phone: 832-393-8023		Date and identification of prior authorizing Council action:															
RECOMMENDATION: Approve and authorize 13 Professional Materials Engineering and Testing Services Laboratory Contracts.																	
Amount and Source of Funding: N/A		Finance Budget:															
<p>SPECIFIC EXPLANATION: The General Services Department (GSD) recommends that City Council approve 13 professional materials engineering and testing services laboratory contracts with the firms listed below to provide materials testing services to support the construction of Capital Improvement Plan projects managed by GSD. The contracts will be funded at the time of the construction award. Each initial contract term is three-years with a one-year renewal option.</p> <p>On March 25, 2016, GSD advertised a Request for Qualifications (RFQ) for materials engineering and testing services for GSD managed construction projects. The RFQ contained selection criteria that ranked respondents on experience and expertise of the contractor and its individual members, technical approach, and quality assurance program. The Statements of Qualifications were due on April 14, 2016 and 13 firms responded. GSD evaluated the respondents and determined that all 13 firms are licensed and have the professional qualifications, experience, and technical approach to perform the services.</p> <table border="0"> <tr> <td>*Austin-Reed Engineers, LLC</td> <td>ECS Texas, LLP</td> </tr> <tr> <td>Kleinfelder, Inc.</td> <td>Alpha Testing, Inc.</td> </tr> <tr> <td>Raba-Kistner, Inc.</td> <td>QC Laboratories, Inc.</td> </tr> <tr> <td>*All-Terra Engineering, Inc.</td> <td>*Gorronzona Engineering Services, Inc.</td> </tr> <tr> <td>*Associated Testing Laboratories, Inc.</td> <td>*Kenall, Inc.</td> </tr> <tr> <td>Professional Services Industries, Inc.</td> <td>*Geotest Engineering, Inc.</td> </tr> <tr> <td>*Geotech Engineering and Testing, inc.</td> <td></td> </tr> </table> <p>* MW/SBE firms.</p> <p>PROJECT LOCATIONS: Citywide</p> <p>SCOPE OF CONTRACT AND FEE: Under the terms of the contract, the firms will be assigned to various projects during the construction phase and will perform materials testing to assure quality control during construction and compliance with engineering design specifications. The specific engineering tests and analysis to be performed will be identified in the respective construction contracts.</p>				*Austin-Reed Engineers, LLC	ECS Texas, LLP	Kleinfelder, Inc.	Alpha Testing, Inc.	Raba-Kistner, Inc.	QC Laboratories, Inc.	*All-Terra Engineering, Inc.	*Gorronzona Engineering Services, Inc.	*Associated Testing Laboratories, Inc.	*Kenall, Inc.	Professional Services Industries, Inc.	*Geotest Engineering, Inc.	*Geotech Engineering and Testing, inc.	
*Austin-Reed Engineers, LLC	ECS Texas, LLP																
Kleinfelder, Inc.	Alpha Testing, Inc.																
Raba-Kistner, Inc.	QC Laboratories, Inc.																
*All-Terra Engineering, Inc.	*Gorronzona Engineering Services, Inc.																
*Associated Testing Laboratories, Inc.	*Kenall, Inc.																
Professional Services Industries, Inc.	*Geotest Engineering, Inc.																
*Geotech Engineering and Testing, inc.																	
REQUIRED AUTHORIZATION			CUIC ID # 25GM320														
General Services Department:  Humberto Bautista, P.E. Assistant Director																	

Date	SUBJECT: Professional Materials Engineering and Testing Services Laboratory Contracts	Originator's Initials GM	Page 2 of 2
-------------	---	--	-----------------------

The consultants will be paid based on the established December 2015 City of Houston Schedule of Fees and the cost of the materials engineering and testing services will be appropriated with the construction award.

M/W/SBE PARTICIPATION: An M/W/SBE goal has not been established for these contracts. The Office of Business Opportunity has reviewed the scope of services and determined that due to the specialized and technical nature of the services, a waiver of the M/W/SBE goal is appropriate as described in the attached correspondence. However, seven of the companies are M/W/SBE firms as marked with an asterisk.

PAY OR PLAY PROGRAM: The proposed contract requires compliance with the City's "Pay or Play" Ordinance regarding health benefits for employees of City contractors. In this case, each consultant will provide health benefits to eligible employees in compliance with City policy.

SM:HB:JLN:GM:gm

c: Marta Crinejo
Jacquelyn L. Nisby
Carlecia Wright
Calvin Curtis
Gabriel Mussio
Felicia Williams
File



CITY OF HOUSTON - CITY COUNCIL

Meeting Date: 10/25/2016

ETJ

Item Creation Date: 10/3/2016

20IPB398 - Petition Addit (9.98) Harris County MUD No. 64

Agenda Item#: 35.

Summary:

ORDINANCE consenting to the addition of 9.98 acres of land to **HARRIS COUNTY MUNICIPAL UTILITY DISTRICT NO. 64**, for inclusion in its district

Background:

SUBJECT: Petition for the City's consent to the addition of 9.98 acres to Harris County Municipal Utility District No. 64 (Key Map No. 444V).

RECOMMENDATION: Petition for the City's consent to the addition of 9.98 acres to Harris County Municipal Utility District No. 64 be approved.

SPECIFIC EXPLANATION: Harris County Municipal Utility District No. 64 has petitioned the City of Houston for consent to add 9.98 acres, located in the extraterritorial jurisdiction of the City, to the district.

The Utility District Review Committee has evaluated the application with respect to wastewater collection and treatment, potable water distribution, storm water conveyance, and other public services.

The district is located in the vicinity of Franz Road, Katy Fort Bend Road, Morton Ranch Road, and Grand Parkway. The district desires to add 9.98 acres, thus yielding a total of 495.532 acres. The district is served by a regional plant, the Williamsburg Regional Sewage Authority. The other districts served by Williamsburg Regional Sewage Authority are Harris County Municipal Utility District No. 61, Harris County Municipal Utility District No. 62, Harris County Municipal Utility District No. 63, Harris County Municipal Utility District No.64, Harris County Municipal Utility District No. 65, West Harris County Municipal Utility District No. 2, West Harris County Municipal Utility District No. 5, and Westside Ventures. The nearest major drainage facility for Harris County Municipal Utility District No. 64 is Mason Creek, which flows into Buffalo Bayou, and finally into the Houston Ship Channel.

Potable water is provided by the district. By executing the Petition for Consent, the district has acknowledged that all plans for the construction of water conveyance, wastewater collection, and storm water collection systems within the district must be approved by the City of Houston prior to their construction.

The Utility District Review Committee recommends that the subject petition be approved.

Dale A. Rudick, P. E., Director
Department of Public Works and Engineering

Contact Information:

Paresh Lad
Acting Deputy Assistant Director
Phone: (832) 395-2690

ATTACHMENTS:

Description

Signed Coversheet

Type

Signed Cover sheet

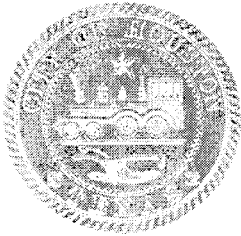
**CITY OF HOUSTON - CITY COUNCIL**

Meeting Date:

ETJ

Item Creation Date: 10/3/2016

20IPB398 - Petition Addit (9.98) Harris County MUD No. 64

Agenda Item#:

Background:

SUBJECT: Petition for the City's consent to the addition of 9.98 acres to Harris County Municipal Utility District No. 64 (Key Map No. 444V).

RECOMMENDATION: Petition for the City's consent to the addition of 9.98 acres to Harris County Municipal Utility District No. 64 be approved.

SPECIFIC EXPLANATION: Harris County Municipal Utility District No. 64 has petitioned the City of Houston for consent to add 9.98 acres, located in the extraterritorial jurisdiction of the City, to the district.

The Utility District Review Committee has evaluated the application with respect to wastewater collection and treatment, potable water distribution, storm water conveyance, and other public services.

The district is located in the vicinity of Franz Road, Katy Fort Bend Road, Morton Ranch Road, and Grand Parkway. The district desires to add 9.98 acres, thus yielding a total of 495.532 acres. The district is served by a regional plant, the Williamsburg Regional Sewage Authority. The other districts served by Williamsburg Regional Sewage Authority are Harris County Municipal Utility District No. 61, Harris County Municipal Utility District No. 62, Harris County Municipal Utility District No. 63, Harris County Municipal Utility District No. 64, Harris County Municipal Utility District No. 65, West Harris County Municipal Utility District No. 2, West Harris County Municipal Utility District No. 5, and Westside Ventures. The nearest major drainage facility for Harris County Municipal Utility District No. 64 is Mason Creek, which flows into Buffalo Bayou, and finally into the Houston Ship Channel.

Potable water is provided by the district. By executing the Petition for Consent, the district has acknowledged that all plans for the construction of water conveyance, wastewater collection, and storm water collection systems within the district must be approved by the City of Houston prior to their construction.

The Utility District Review Committee recommends that the subject petition be approved.

Dale A. Rudick, P. E., Director

Department of Public Works and Engineering

Contact Information:

Paresh Lad
Acting Deputy Assistant Director
Phone: (832) 395-2690

ATTACHMENTS:

Description	Type
<u>Application</u>	Backup Material
<u>Petition</u>	Backup Material
<u>Exhibit A - Metes and Bounds</u>	Backup Material
<u>Exhibit B - Consent Conditions</u>	Backup Material
<u>Certificates of Lienholders</u>	Backup Material
<u>Water Authority Notification Letter</u>	Backup Material
<u>Vicinity Map</u>	Backup Material
<u>Survey Map</u>	Backup Material



CITY OF HOUSTON - CITY COUNCIL

Meeting Date: 10/25/2016

ETJ

Item Creation Date: 9/30/2016

20IPB397 - Petition Addit (45.3788) Harris County MUD No.
148

Agenda Item#: 36.

Summary:

ORDINANCE consenting to the addition of 45.3788 acres of land to **HARRIS COUNTY MUNICIPAL UTILITY DISTRICT NO. 148**, for inclusion in its district

Background:

SUBJECT: Petition for the City's consent to the addition of 45.3788 acres to Harris County Municipal Utility District No. 148 (Key Map No. 416M; 417J).

RECOMMENDATION: Petition for the City's consent to the addition of 45.3788 acres to Harris County Municipal Utility District No. 148 be approved.

SPECIFIC EXPLANATION: Harris County Municipal Utility District No. 148 has petitioned the City of Houston for consent to add 45.3788 acres, located in the extraterritorial jurisdiction of the City, to the district.

The Utility District Review Committee has evaluated the application with respect to wastewater collection and treatment, potable water distribution, storm water conveyance, and other public services.

The district is located in the vicinity of Garrett Road, East Sam Houston Parkway – Beltway 8, North Lake Houston Parkway, and Lake Houston Parkway. The district desires to add 45.3788 acres, thus yielding a total of 756.3048 acres. The district is served by a district plant, the Harris County Municipal Utility District No. 148 Plant No. 2. The nearest major drainage facility for Harris County Municipal Utility District No. 148 is Greens Bayou, which flows into the Houston Ship Channel.

Potable water is provided by the district. By executing the Petition for Consent, the district has acknowledged that all plans for the construction of water conveyance, wastewater collection, and storm water collection systems within the district must be approved by the City of Houston prior to their construction.

The Utility District Review Committee recommends that the subject petition be approved.

Dale A. Rudick, P. E., Director

Department of Public Works and Engineering

Contact Information:

Paresh Lad

Acting Deputy Assistant Director

Phone: (832) 395-2690

ATTACHMENTS:

Description

Signed Coversheet

Type

Signed Cover sheet



CITY OF HOUSTON - CITY COUNCIL

Meeting Date:

ETJ

Item Creation Date: 9/30/2016

20IPB397 - Petition Addit (45.3788) Harris County MUD No. 148

Agenda Item#:

Background:

SUBJECT: Petition for the City's consent to the addition of 45.3788 acres to Harris County Municipal Utility District No. 148 (Key Map No. 416M; 417J).

RECOMMENDATION: Petition for the City's consent to the addition of 45.3788 acres to Harris County Municipal Utility District No. 148 be approved.

SPECIFIC EXPLANATION: Harris County Municipal Utility District No. 148 has petitioned the City of Houston for consent to add 45.3788 acres, located in the extraterritorial jurisdiction of the City, to the district.

The Utility District Review Committee has evaluated the application with respect to wastewater collection and treatment, potable water distribution, storm water conveyance, and other public services.

The district is located in the vicinity of Garrett Road, East Sam Houston Parkway – Beltway 8, North Lake Houston Parkway, and Lake Houston Parkway. The district desires to add 45.3788 acres, thus yielding a total of 756.3048 acres. The district is served by a district plant, the Harris County Municipal Utility District No. 148 Plant No. 2. The nearest major drainage facility for Harris County Municipal Utility District No. 148 is Greens Bayou, which flows into the Houston Ship Channel.

Potable water is provided by the district. By executing the Petition for Consent, the district has acknowledged that all plans for the construction of water conveyance, wastewater collection, and storm water collection systems within the district must be approved by the City of Houston prior to their construction.

The Utility District Review Committee recommends that the subject petition be approved.

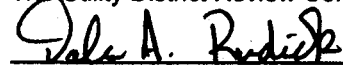

Dale A. Rudick, P. E., Director
Department of Public Works and Engineering

Contact Information:

Paresh Lad
Acting Deputy Assistant Director
Phone: (832) 395-2690

ATTACHMENTS:

Description	Type
<u>Application</u>	Backup Material
<u>Petition</u>	Backup Material
<u>Exhibit A - Metes and Bounds</u>	Backup Material
<u>Exhibit B - Consent Conditions</u>	Backup Material
<u>Certificates of Lienholders</u>	Backup Material
<u>Vicinity Map</u>	Backup Material
<u>Survey Map</u>	Backup Material



CITY OF HOUSTON - CITY COUNCIL

Meeting Date: 10/25/2016

ETJ

Item Creation Date: 9/13/2016

20IPB392 - Petition Creation (395.96) Harris County MUD
No. 538

Agenda Item#: 37.

Summary:

ORDINANCE consenting to the creation of **HARRIS COUNTY MUNICIPAL UTILITY DISTRICT NO. 538**

Background:

SUBJECT: Petition for the City's consent to the creation of Harris County Municipal Utility District No. 538 consisting of 395.96 acres of land. (Key Map No. 404V; 405N; 405S; 405T; 405W; 405X).

RECOMMENDATION: Petition for the creation of Harris County Municipal Utility District No. 538 consisting of 395.96 acres of land be approved.

SPECIFIC EXPLANATION: The owners of 395.96 acres of land, located in the extraterritorial jurisdiction of the City, have petitioned the City of Houston for consent to create a district.

The Utility District Review Committee has evaluated the application with respect to wastewater collection and treatment, potable water distribution, storm water conveyance, and other public services.

The district is located in the vicinity of Clay Road, Katy Hockley Cut Off Road, FM 529, and Peek Road. The district will consist of 395.96 acres. The district would be served by a regional plant, the Harris County Municipal Utility District No. 495 Wastewater Treatment Plant, which will also serve Harris County Municipal Utility District No. 495. The nearest major drainage facility for Harris County Municipal Utility District No. 538 would be Oyster Creek, which flows into Mason Creek, then into Buffalo Bayou, and finally into the Houston Ship Channel.

Potable water will be provided by the district. By executing the Petition for Consent, the district has acknowledged that all plans for the construction of water conveyance, wastewater collection, and storm water collection systems within the district must be approved by the City of Houston prior to their construction.

The Utility District Review Committee recommends that the subject petition be approved.

Dale A. Rudick, P. E., Director
Department of Public Works and Engineering

Contact Information:

Paresh Lad

Acting Deputy Assistant Director

Phone: (832) 395-2690

ATTACHMENTS:

Description

Signed Coversheet

Survey Map

Type

Signed Cover sheet

Backup Material

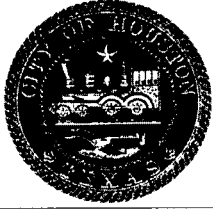

CITY OF HOUSTON - CITY COUNCIL

Meeting Date:

ETJ

Item Creation Date: 9/13/2016

20IPB392 - Petition Creation (395.96) Harris County MUD No. 538

Agenda Item#:

Background:

SUBJECT: Petition for the City's consent to the creation of Harris County Municipal Utility District No. 538 consisting of 395.96 acres of land. (Key Map No. 404V; 405N; 405S; 405T; 405W; 405X).

RECOMMENDATION: Petition for the creation of Harris County Municipal Utility District No. 538 consisting of 395.96 acres of land be approved.

SPECIFIC EXPLANATION: The owners of 395.96 acres of land, located in the extraterritorial jurisdiction of the City, have petitioned the City of Houston for consent to create a district.

The Utility District Review Committee has evaluated the application with respect to wastewater collection and treatment, potable water distribution, storm water conveyance, and other public services.

The district is located in the vicinity of Clay Road, Katy Hockley Cut Off Road, FM 529, and Peek Road. The district will consist of 395.96 acres. The district would be served by a regional plant, the Harris County Municipal Utility District No. 495 Wastewater Treatment Plant, which will also serve Harris County Municipal Utility District No. 495. The nearest major drainage facility for Harris County Municipal Utility District No. 538 would be Oyster Creek, which flows into Mason Creek, then into Buffalo Bayou, and finally into the Houston Ship Channel.

Potable water will be provided by the district. By executing the Petition for Consent, the district has acknowledged that all plans for the construction of water conveyance, wastewater collection, and storm water collection systems within the district must be approved by the City of Houston prior to their construction.

The Utility District Review Committee recommends that the subject petition be approved.

Dale A. Rudick, P. E., Director
Department of Public Works and Engineering

Contact Information:

Paresh Lad
Acting Deputy Assistant Director
Phone: (832) 395-2690

ATTACHMENTS:

Description	Type
<u>Application</u>	Backup Material
<u>Petition</u>	Backup Material
<u>Exhibit A - Metes and Bounds</u>	Backup Material
<u>Exhibit B - Consent Conditions</u>	Backup Material
<u>Certificate of Authority</u>	Backup Material
<u>Certificate of Lienholder's Consent</u>	Backup Material
<u>Availability of Utility Services</u>	Backup Material
<u>Water Authority Notification Letter</u>	Backup Material
<u>Vicinity Map</u>	Backup Material
<u>Survey Map</u>	Backup Material

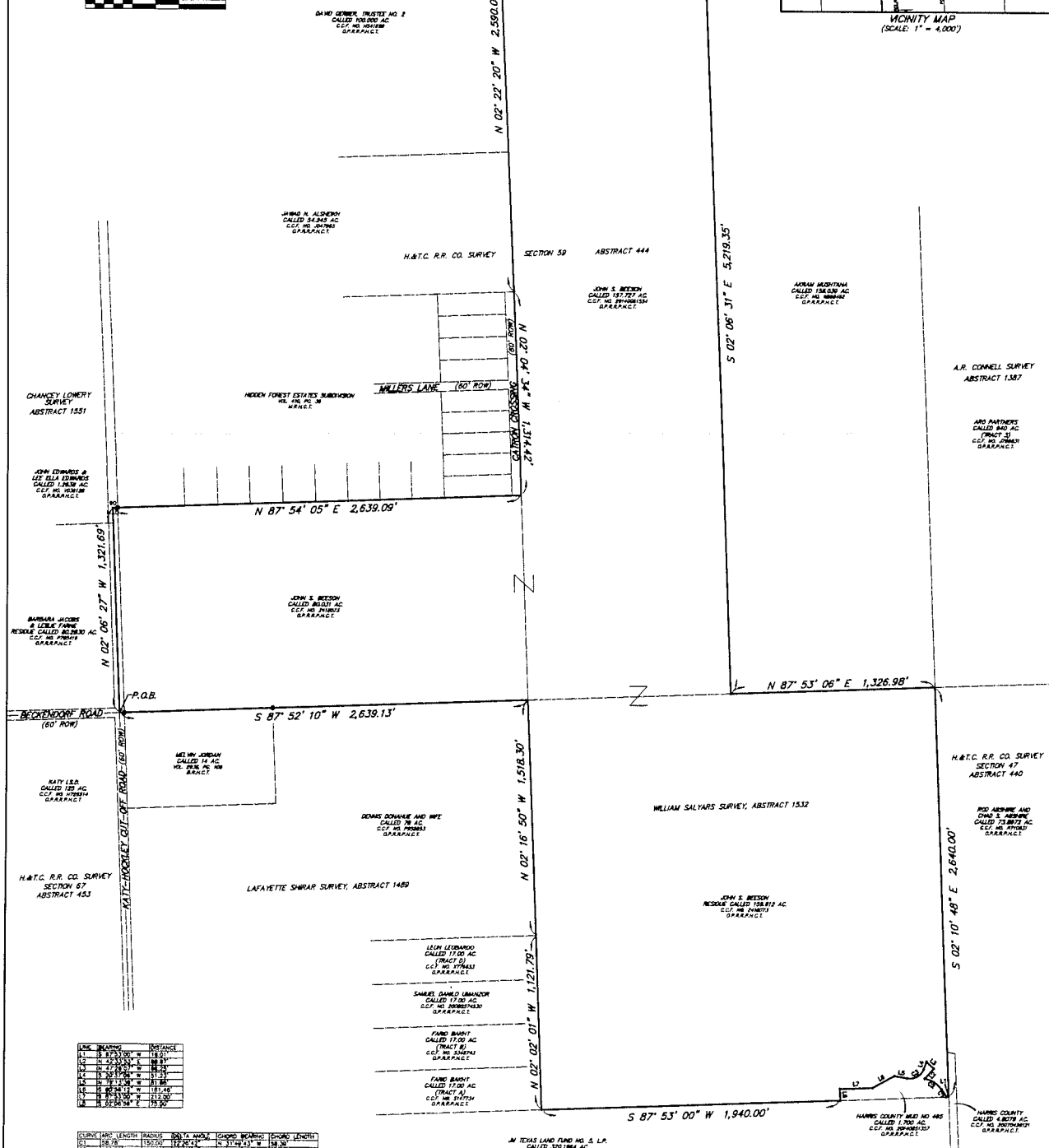
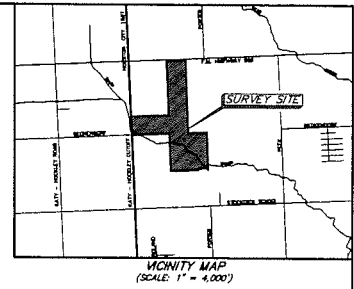
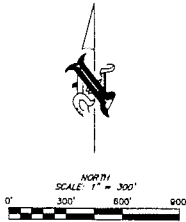

LINE NUMBER	BEARING	DISTANCE
1	N 87° 54' 43\"/>	

LINE NO.	BEARING	DISTANCE	AREA (AC)
1	N 87° 54' 43\"/>		

This document prepared under TAC 863.21 does not reflect the results of an on the ground survey and is not to be used to convey or establish interests in real property except those rights and interests implied or created by the location of a portion of the boundary of the property for which it was prepared. The bearings and distances shown herein are based on the Texas Coordinate System, South Central Zone, NAD83, based upon GPS measurements. A notice and receipt description of Harris County Assessor (TTC) District Number 538 is on file in the office of James A. Carter, Inc., Houston, Texas.

I, Chris D. Kalkomey, a Registered Professional Land Surveyor, do hereby certify that this map accurately describes the boundaries of Harris County Municipal Utility District No. 538. WITNESS MY HAND AND SEAL this 10th day of October, 2014.



Chris D. Kalkomey
Registered Professional Land Surveyor
No. 5069

POLITICAL BOUNDARY MAP OF HARRIS COUNTY MUNICIPAL UTILITY DISTRICT No. 538

BEING 395.96 ACRES OUT OF THE WILLIAM SLYARS SURVEY, ABSTRACT 1532 H. & T.C. R.R. CO. SURVEY, SECTION 59, ABSTRACT 444 HARRIS COUNTY, TEXAS

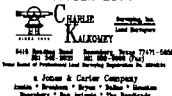

James A. Carter Company
Surveyors & Engineers
Houston, Texas



CITY OF HOUSTON - CITY COUNCIL

Meeting Date: 10/25/2016

ETJ

Item Creation Date: 10/3/2016

20IPB400 - Petition Addit (4.4822) Montgomery County
Water Control and Improvement District No. 1

Agenda Item#: 38.

Summary:

ORDINANCE consenting to the addition of 4.4822 acres of land to **MONTGOMERY COUNTY WATER CONTROL AND IMPROVEMENT DISTRICT NO. 1**, for inclusion in its district

Background:

SUBJECT: Petition for the City's consent to the addition of 4.4822 acres to Montgomery County Water Control and Improvement District No. 1 (Key Map No. 251U; 251Y).

RECOMMENDATION: Petition for the City's consent to the addition 4.4822 acres to Montgomery County Water Control and Improvement District No. 1 be approved.

SPECIFIC EXPLANATION: Montgomery County Water Control and Improvement District No. 1 has petitioned the City of Houston for consent to add 4.4822 acres, located in the extraterritorial jurisdiction of the City, to the district.

The Utility District Review Committee has evaluated the application with respect to wastewater collection and treatment, potable water distribution, storm water conveyance, and other public services.

The district is located in the vicinity of Sawdust Road, Grogan Mill's Road, Sawdust Road, and Sawmill Road. The district desires to add 4.4822 acres, thus yielding a total of 1,091.2335 acres. The district is served by the Montgomery County Water Control and Improvement District No. 1 Wastewater Treatment Facility, which is owned and operated by the district. The nearest major drainage facility for Montgomery County Water Control and Improvement District No. 1 is Spring Creek which flows into the San Jacinto River, and finally into Lake Houston.

Potable water is provided by the district. By executing the Petition for Consent, the district has acknowledged that all plans for the construction of water conveyance, wastewater collection, and storm water collection systems within the district must be approved by the City of Houston prior to their construction.

The Utility District Review Committee recommends that the subject petition be approved.

Dale A. Rudick, P. E., Director

Department of Public Works and Engineering

Contact Information:

Paresh Lad

Acting Deputy Assistant Director

Phone: (832) 395-2690

ATTACHMENTS:

Description

Signed Coversheet

Type

Signed Cover sheet

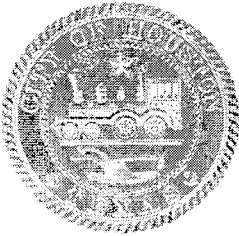

CITY OF HOUSTON - CITY COUNCIL

Meeting Date:

ETJ

Item Creation Date: 10/3/2016

20IPB400 - Petition Addit (4.4822) Montgomery County Water Control and Improvement District No. 1

Agenda Item#:

Background:

SUBJECT: Petition for the City's consent to the addition of 4.4822 acres to Montgomery County Water Control and Improvement District No. 1 (Key Map No. 251U; 251Y).

RECOMMENDATION: Petition for the City's consent to the addition 4.4822 acres to Montgomery County Water Control and Improvement District No. 1 be approved.

SPECIFIC EXPLANATION: Montgomery County Water Control and Improvement District No. 1 has petitioned the City of Houston for consent to add 4.4822 acres, located in the extraterritorial jurisdiction of the City, to the district.

The Utility District Review Committee has evaluated the application with respect to wastewater collection and treatment, potable water distribution, storm water conveyance, and other public services.

The district is located in the vicinity of Sawdust Road, Grogan Mill's Road, Sawdust Road, and Sawmill Road. The district desires to add 4.4822 acres, thus yielding a total of 1,091.2335 acres. The district is served by the Montgomery County Water Control and Improvement District No. 1 Wastewater Treatment Facility, which is owned and operated by the district. The nearest major drainage facility for Montgomery County Water Control and Improvement District No. 1 is Spring Creek which flows into the San Jacinto River, and finally into Lake Houston.

Potable water is provided by the district. By executing the Petition for Consent, the district has acknowledged that all plans for the construction of water conveyance, wastewater collection, and storm water collection systems within the district must be approved by the City of Houston prior to their construction.

The Utility District Review Committee recommends that the subject petition be approved.

Dale A. Rudick, P. E., Director
Department of Public Works and Engineering

Contact Information:

Paresh Lad
Acting Deputy Assistant Director
Phone: (832) 395-2690

ATTACHMENTS:

Description	Type
Application	Backup Material
Petition	Backup Material
Exhibit A - Metes and Bounds	Backup Material
Exhibit B - Consent Conditions	Backup Material
Certificates of Authority	Backup Material
Certificate of Resolution	Backup Material
Petition to District	Backup Material
Vicinity Map	Backup Material
Survey Map	Backup Material



CITY OF HOUSTON - CITY COUNCIL

Meeting Date: 10/25/2016

ETJ

Item Creation Date: 9/28/2016

20IPB399 - Petition Addit (3.837) Reid Road MUD No. 1

Agenda Item#: 39.

Summary:

ORDINANCE consenting to the addition of 3.837 acres of land to **REID ROAD MUNICIPAL UTILITY DISTRICT NO. 1**, for inclusion in its district

Background:

SUBJECT: Petition for the City's consent to the addition of 3.837 acres to Reid Road Municipal Utility District No. 1 (Key Map No. 369U).

RECOMMENDATION: Petition for the City's consent to the addition of 3.837 acres to Reid Road Municipal Utility District No. 1 be approved.

SPECIFIC EXPLANATION: Reid Road Municipal Utility District No. 1 has petitioned the City of Houston for consent to add 3.837 acres, located in the extraterritorial jurisdiction of the City, to the district.

The Utility District Review Committee has evaluated the application with respect to wastewater collection and treatment, potable water distribution, storm water conveyance, and other public services.

The district is located in the vicinity of Windfern Road, FM 1960, Jones Road, and Bobcat Road. The district desires to add 3.837 acres, thus yielding a total of 568.4039 acres. The district is served by a regional plant, the Harvest Bend Treatment Plant. The other district served by this plant is Reid Road Municipal Utility District No. 2. The nearest major drainage facility for Reid Road Municipal Utility District No. 1 is White Oak Bayou which flows into Buffalo Bayou which flows finally into the Houston Ship Channel.

Potable water is provided by the district. By executing the Petition for Consent, the district has acknowledged that all plans for the construction of water conveyance, wastewater collection, and storm water collection systems within the district must be approved by the City of Houston prior to their construction.

The Utility District Review Committee recommends that the subject petition be approved.

Dale A. Rudick, P. E., Director

Department of Public Works and Engineering

Contact Information:

Paresh Lad

Acting Deputy Assistant Director

Phone: (832) 395-2690

ATTACHMENTS:

Description

Signed Coversheet

Type

Signed Cover sheet

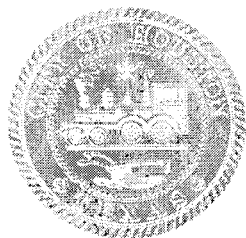

CITY OF HOUSTON - CITY COUNCIL

Meeting Date:

ETJ

Item Creation Date: 9/28/2016

20IPB399 - Petition Addit (3.837) Reid Road MUD No. 1

Agenda Item#:

Background:

SUBJECT: Petition for the City's consent to the addition of 3.837 acres to Reid Road Municipal Utility District No. 1 (Key Map No. 369U).

RECOMMENDATION: Petition for the City's consent to the addition of 3.837 acres to Reid Road Municipal Utility District No. 1 be approved.

SPECIFIC EXPLANATION: Reid Road Municipal Utility District No. 1 has petitioned the City of Houston for consent to add 3.837 acres, located in the extraterritorial jurisdiction of the City, to the district.

The Utility District Review Committee has evaluated the application with respect to wastewater collection and treatment, potable water distribution, storm water conveyance, and other public services.

The district is located in the vicinity of Windfern Road, FM 1960, Jones Road, and Bobcat Road. The district desires to add 3.837 acres, thus yielding a total of 568.4039 acres. The district is served by a regional plant, the Harvest Bend Treatment Plant. The other district served by this plant is Reid Road Municipal Utility District No. 2. The nearest major drainage facility for Reid Road Municipal Utility District No. 1 is White Oak Bayou which flows into Buffalo Bayou which flows finally into the Houston Ship Channel.

Potable water is provided by the district. By executing the Petition for Consent, the district has acknowledged that all plans for the construction of water conveyance, wastewater collection, and storm water collection systems within the district must be approved by the City of Houston prior to their construction.

The Utility District Review Committee recommends that the subject petition be approved.

Dale A. Rudick, P. E., Director
Department of Public Works and Engineering

Contact Information:

Paresh Lad
Acting Deputy Assistant Director
Phone: (832) 395-2690

ATTACHMENTS:

Description

Application

Petition

Exhibit A - Metes and Bounds

Exhibit B - Consent Conditions

Certificates of Lienholders

Vicinity Map

Survey Map

Letter to North Harris County Regional Water Authority

Type

Backup Material

Backup Material

Backup Material

Backup Material

Backup Material

Backup Material

Backup Material

Backup Material



CITY OF HOUSTON - CITY COUNCIL

Meeting Date: 10/25/2016

ALL

Item Creation Date: 10/6/2016

20UPA342 - Developer Participation Contracts

Agenda Item#: 40.

Summary:

ORDINANCE appropriating \$3,000,000.00 out of Water & Sewer System Consolidated Construction Fund and \$1,018,000.00 out of Street & Traffic Control & Storm Drainage DDSRF for Fiscal Year 2017 Funding for Developer Participation Contracts (Approved by Ordinance No. 2008-0307, as amended)

Background:

SUBJECT: Ordinance appropriating FY17 funding for the Developer Participation Contracts

S-000800-DPC1-7/R-000800-DPC1-7/M-430800-DPC1-7

RECOMMENDATION: (Summary)

Adopt an ordinance appropriating funding for Developer Participation Contract, Water, Sanitary Sewer, and Storm Drainage for FY17

SPECIFIC EXPLANATION:

In accordance with Chapter 47 regarding the Developer Participation Program (Ordinance Number 2008-0307), the Director of the Department of Public Works and Engineering requests Council approval of the appropriations necessary to fund Developer Participation Contracts, Water, Sanitary Sewer, and Storm Drainage for FY17. When a DPC application is administratively complete, but at least 10 days prior to approval by the Director, the Department shall provide the members of the City Council notice of the scope and location of the proposed budget as well as contact information for the developer.

The funding requested for FY17 will provide \$4,018,000 to be available for new development projects in FY17 for water, sanitary sewer and storm drainage.

ESTIMATED FISCAL OPERATING IMPACT:

PROJECT WBS#	FY17	FY18	FY19	FY20	FY21	FY17-FY21 Total
S-000800-DPC1-7	\$0	\$0	\$0	\$0	\$0	\$0
R-000800-DPC1-7	\$0	\$0	\$0	\$0	\$0	\$0
M-430800-DPC1-7	\$0	\$0	\$0	\$0	\$0	\$0

No significant Fiscal Operating impact is anticipated as a result of this project

Prior Council Action:

Ordinance Number 2008-307, dated April 9, 2008

Amount of Funding:

FY16 appropriation \$4,018,000.00;

\$3,000,000.00 from the Water and Sewer System Consolidated Construction Fund 8500

\$1,018,000.00 from the Street & Traffic Control & Storm Drainage DDSRF Fund 4042

Contact Information:

Mark L. Loethen, P.E., CFM, PTOE

Deputy Director

Planning and Development Services Divison

Phone Number 832-395-2705

ATTACHMENTS:

Description

Signed RCA

Type

Signed Cover sheet

TO: Mayor via City Secretary REQUEST FOR COUNCIL ACTION

SUBJECT: Ordinance appropriating FY17 funding for the Developer Participation Contracts S-000800-DPC1-7/R-000800-DPC1-7/M-430800-DPC1-7	Page 1 of 1	Agenda Item #
---	-----------------------	-------------------------

FROM (Department or other point of origin): Department of Public Works and Engineering	Origination Date	Agenda Date
--	-------------------------	--------------------

DIRECTOR'S SIGNATURE  Dale A. Rudick, P.E.	Council District affected: All
--	--

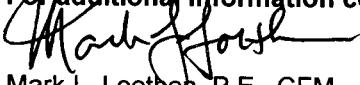
For additional information contact:  Mark L. Loethen, P.E., CFM Phone No. 832-395-2705 Deputy Director	Date and identification of prior authorizing Council action: Ordinance No. 2008-307, dated April 9, 2008
--	--

RECOMMENDATION: (Summary)
Adopt an ordinance appropriating funding for Developer Participation Contract, Water, Sanitary Sewer, and Storm Drainage for FY17

Amount and Source of Funding:
FY16 appropriation \$4,018,000.00
\$3,000,000.00 from the Water and Sewer System Consolidated Construction Fund 8500
\$1,018,000.00 from the Street & Traffic Control & Storm Drainage DDSRF Fund 4042 *M.P. 10/6/2016*

SPECIFIC EXPLANATION:
In accordance with Chapter 47 regarding the Developer Participation Program (Ordinance Number 2008-0307), the Director of the Department of Public Works and Engineering requests Council approval of the appropriations necessary to fund Developer Participation Contracts, Water, Sanitary Sewer, and Storm Drainage for FY17. When a DPC application is administratively complete, but at least 10 days prior to approval by the Director, the Department shall provide the members of the City Council notice of the scope and location of the proposed budget as well as contact information for the developer.

The funding requested for FY17 will provide \$4,018,000 to be available for new development projects in FY17 for water, sanitary sewer and storm drainage.

ESTIMATED FISCAL OPERATING IMPACT:

PROJECT WBS#s	FY17	FY18	FY19	FY20	FY21	FY17-FY21 Total
S-000800-DPC1-7	\$0	\$0	\$0	\$0	\$0	\$0
R-000800-DPC1-7	\$0	\$0	\$0	\$0	\$0	\$0
M-430800-DPC1-7	\$0	\$0	\$0	\$0	\$0	\$0

No significant Fiscal Operating impact is anticipated as a result of this project.

LTS No. 16481	CUIC No. 20UPA342
----------------------	--------------------------

Finance Department	Other Authorization:  Mark L. Loethen, P.E., CFM, PTOE Deputy Director Planning and Development Services Division	Other Authorization:
---------------------------	---	-----------------------------



CITY OF HOUSTON - CITY COUNCIL

Meeting Date: 10/25/2016

ALL

Item Creation Date: 9/28/2016

C25769 – Concrete Panel Replacement for City Streets - ORDINANCE

Agenda Item#: 41.

Summary:

ORDINANCE awarding contracts to **MAIN LANE INDUSTRIES, LTD.** and **ISI CONTRACTING, INC** for Concrete Panel Replacement for City streets for the Department of Public Works & Engineering; setting a deadline for the bidder's execution of the contract and delivery of all bonds, insurance, and other required contract documents to the City; holding the bidder in default if it fails to meet the deadlines - Four-years with one option year to extend - \$32,992,042.60 - Dedicated Drainage & Street Renewal Fund

Background:

Formal Bids Received for S63-C25769 – Approve an Ordinance awarding contracts to Main Lane Industries, Ltd and ISI Contracting, Inc. for a total amount not to exceed \$32,992,042.60 for Concrete Panel Replacement for City Streets for the Department of Public Works and Engineering

SPECIFIC EXPLANATION:

The Director of the Department of Public Works and Engineering and the Chief Procurement Officer recommend that City Council approve an ordinance awarding **four-year contracts with one option year to extend, for a total of five-year terms** to **Main Lane Industries, Ltd.** (quadrants 1 and 2) on its low bid not to exceed **\$8,833,742.60** and **ISI Contracting, Inc.** (quadrants 3 and 4) on its low bid not to exceed **\$24,158,300.00** for concrete panel replacement for city streets for the Department of Public Works and Engineering. The Chief Procurement Officer may terminate this contract at any time upon 30-days written notice to the contractors.

This project was advertised in accordance with the requirements of the State of Texas bid laws. Seventy-six prospective bidders downloaded the solicitation document from SPD's e-bidding website and ten bids were received as detailed below:

Quadrant 1 – Northeast

COMPANY

1. J. Simmons Group, Inc.
- 2. Main Lane Industries, Ltd.**
3. ISI Contracting, Inc.
4. Ally General Solutions

TOTAL AMOUNT

- \$3,963,375.20 (Non-Responsive Bid)
\$4,416,871.30
\$4,503,695.00
\$5,254,653.00

5. Resicom, Inc.	\$6,293,620.00
6. Reytec Construction Resources	\$10,813,179.00

Quadrant 2 – Northwest

<u>COMPANY</u>	<u>TOTAL AMOUNT</u>
1. J. Simmons Group, Inc.	\$3,963,375.20 (Non-Responsive Bid)
2. Main Lane Industries, Ltd.	\$4,416,871.30
3. ISI Contracting, Inc.	\$4,520,295.00
4. Ally General Solutions	\$5,247,841.80
5. Resicom, Inc.	\$6,400,050.00
6. Reytec Construction Resources	\$10,813,179.00

Quadrant 3 – Southeast

<u>COMPANY</u>	<u>TOTAL AMOUNT</u>
1. J. Simmons Group, Inc.	\$7,859,859.30 (Non-Responsive Bid)
2. ISI Contracting, Inc.	\$8,031,100.00
3. W & R Construction Co., LLC.	\$8,408,150.00
4. Main Lane Industries, Ltd.	\$8,557,572.68
5. Grava LLC	\$9,761,824.30
6. Ti-Zack Concrete, Inc.	\$15,351,118.90
7. Resicom, Inc.	\$47,684,360.00
8. Reytec Construction Resources	\$21,112,240.00

Quadrant 4 – Southwest

<u>COMPANY</u>	<u>TOTAL AMOUNT</u>
1. J. Simmons Group, Inc.	\$15,584,010.60 (Non-Responsive Bid)
2. ISI Contracting, Inc.	\$16,127,200.00
3. Main Lane Industries, Ltd.	\$17,000,633.72
4. Resicom, Inc.	\$23,046,220.00
5. Ti-Zack Concrete, Inc.	\$29,455,994.20
6. Reytec Construction Resources	\$41,568,180.00

The scope of work requires the contractors to provide all labor, materials, equipment, tools, permits, supervision and transportation necessary to provide concrete panel replacement for city streets and shall be required to comply with all the City of Houston Building Codes, City of Houston Construction Standard Specifications and Construction Standard Details. The work order contracts will assist PW&E in repairing city streets, including driveways, wheelchair ramps, walkways, including street paving to ensure safe and secure street surfaces. Materials and workmanship for this project are warranted for one year upon completion and acceptance of each work order.

MBE and WBE Subcontracting:

This invitation to bid was issued as a goal-oriented contract with a 23% MBE and an 11% WBE participation level.

Main Lane Industries, Ltd. designated the below-named companies as its MBE and WBE

subcontractors.

<u>Name</u>	<u>Type of Work</u>	<u>Dollar Amount</u>	<u>Percentage</u>
Castec Construction, LLC	Concrete paving	\$1,236,723.96	14%
Alamo Ready Mix, LLC.	Ready mix concrete	\$795,036.83	9%
H & E Aggregate, LLC.	Cement stabilization sand	\$530,024.55	6%
C.M. Nunez Trucking	Dump trucking	\$353,349.70	4%
Rebar Supply Company, Ltd.	Fabricated structural steel	\$176,674.85	2%
Holes Incorporated	Concrete breaking/sawing	\$88,337.42	1%
	Total	\$3,180,147.31	36%

ISI Contracting, Inc. designated the below-named companies as its MBE and WBE subcontractors.

<u>Name</u>	<u>Type of Work</u>	<u>Dollar Amount</u>	<u>Percentage</u>
Access Data Supply, Inc.	Concrete aggregate	\$3,370,082.85	13.95%
Holes Incorporated	Sawing	\$1,693,496.83	7.01%
H & E Aggregate, LLC.	Stabilized base	\$1,157,182.57	4.79%
PMG Project Management Group	Concrete repairs	\$1,050,886.05	4.35%
Romar Unlimited Inc.	Trucking	\$623,284.14	2.58%
Republic Traffic Safety	Traffic Control	\$553,225.07	2.29%
	Total	\$8,448,157.51	34.97%

The Office of Business Opportunity will monitor these contracts.

Hire Houston First:

The proposed contracts require compliance with the City's "Hire Houston First" (HHF) ordinance that promotes economic opportunity for Houston businesses and supports job creation. In this case, the proposed contractors do not meet the requirements of Hire Houston First; no Hire Houston First firms were within three percent.

Pay or Play:

The proposed contracts require compliance with the City's "Pay or Play" ordinance regarding health benefits for employees of City contractors. In this case, Main Lane Industries, LTD. provides health benefits to eligible employees in compliance with City policy and ISI Contracting, Inc. has elected to pay into the Contractor Responsibility Fund and provide health benefits to eligible employees in compliance with City policy.

Fiscal Note:

Funding for this item is included in the FY 2017 Adopted Budget. Therefore, no Fiscal Note is required as stated in the Financial Policy Ord. 2014-1078.

John J. Gillespie, Chief Procurement Officer
Finance/Strategic Procurement Division

Department Approval Authority Signature

Estimated Spending Authority:

Department	FY 2017	Out Years	Total
Department of Public Works and Engineering	\$8,485,900.00	\$24,506,142.60	\$32,992,042.60

Amount of Funding:

\$32,992,042.60 – Dedicated Drainage & Street Renewal Fund (2310)

Contact Information:

NAME:	DEPARTMENT/DIVISION	PHONE
David Guernsey, Assistant Director	PWE	(832) 395-3640
Martin King, Division Manager	FIN/SPD	(832) 393-8705
Yesenia Chuca, Sr. Procurement Specialist	FIN/SPD	(832) 393-8727

ATTACHMENTS:

Description

RCA#C25769- Main Lane Industries, Ltd. and ISI Contracting, Inc.

Type

Signed Cover sheet



CITY OF HOUSTON - CITY COUNCIL

Meeting Date: 10/25/2016

ALL

Item Creation Date: 9/28/2016

C25769 – Concrete Panel Replacement for City Streets - ORDINANCE

Agenda Item#: 18.

Background:

Formal Bids Received for S63-C25769 – Approve an Ordinance awarding contracts to Main Lane Industries, Ltd and ISI Contracting, Inc. for a total amount not to exceed \$32,992,042.60 for Concrete Panel Replacement for City Streets for the Department of Public Works and Engineering

SPECIFIC EXPLANATION:

The Director of the Department of Public Works and Engineering and the Chief Procurement Officer recommend that City Council approve an ordinance awarding four-year contracts with one option year to extend, for a total of five-year terms to Main Lane Industries, Ltd. (quadrants 1 and 2) on its low bid not to exceed \$8,833,742.60 and ISI Contracting, Inc. (quadrants 3 and 4) on its low bid not to exceed \$24,158,300.00 for concrete panel replacement for city streets for the Department of Public Works and Engineering. The Chief Procurement Officer may terminate this contract at any time upon 30-days written notice to the contractors.

This project was advertised in accordance with the requirements of the State of Texas bid laws. Seventy-six prospective bidders downloaded the solicitation document from SPD's e-bidding website and ten bids were received as detailed below:

Quadrant 1 – Northeast

<u>COMPANY</u>	<u>TOTAL AMOUNT</u>
1. J. Simmons Group, Inc.	\$3,963,375.20 (Non-Responsive Bid)
2. Main Lane Industries, Ltd.	\$4,416,871.30
3. ISI Contracting, Inc.	\$4,503,695.00
4. Ally General Solutions	\$5,254,653.00
5. Resicom, Inc.	\$6,293,620.00
6. Reytec Construction Resources	\$10,813,179.00

Quadrant 2 – Northwest

<u>COMPANY</u>	<u>TOTAL AMOUNT</u>
1. J. Simmons Group, Inc.	\$3,963,375.20 (Non-Responsive Bid)
2. Main Lane Industries, Ltd.	\$4,416,871.30
3. ISI Contracting, Inc.	\$4,520,295.00
4. Ally General Solutions	\$5,247,841.80
5. Resicom, Inc.	\$6,400,050.00
6. Reytec Construction Resources	\$10,813,179.00

Quadrant 3 – Southeast

<u>COMPANY</u>	<u>TOTAL AMOUNT</u>
1. J. Simmons Group, Inc.	\$7,859,859.30 (Non-Responsive Bid)
2. ISI Contracting, Inc.	\$8,031,100.00
3. W & R Construction Co., LLC.	\$8,408,150.00
4. Main Lane Industries, Ltd.	\$8,557,572.68
5. Grava LLC	\$9,761,824.30
6. Ti-Zack Concrete, Inc.	\$15,351,118.90
7. Resicom, Inc.	\$47,684,360.00
8. Reytec Construction Resources	\$21,112,240.00

Quadrant 4 – Southwest

<u>COMPANY</u>	<u>TOTAL AMOUNT</u>
	\$15,584,010.60 (Non-Responsive Bid)
1. J. Simmons Group, Inc.	
2. ISI Contracting, Inc.	\$16,127,200.00
3. Main Lane Industries, Ltd.	\$17,000,633.72
4. Resicom, Inc.	\$23,046,220.00
5. Ti-Zack Concrete, Inc.	\$29,455,994.20
6. Reytec Construction Resources	\$41,568,180.00

The scope of work requires the contractors to provide all labor, materials, equipment, tools, permits, supervision and transportation necessary to provide concrete panel replacement for city streets and shall be required to comply with all the City of Houston Building Codes, City of Houston Construction Standard Specifications and Construction Standard Details. The work order contracts will assist PW&E in repairing city streets, including driveways, wheelchair ramps, walkways, including street paving to ensure safe and secure street surfaces. Materials and workmanship for this project are warranted for one year upon completion and acceptance of each work order.

MBE and WBE Subcontracting:

This invitation to bid was issued as a goal-oriented contract with a 23% MBE and an 11% WBE participation level.

Main Lane Industries, Ltd. designated the below-named companies as its MBE and WBE subcontractors.

<u>Name</u>	<u>Type of Work</u>	<u>Dollar Amount</u>	<u>Percentage</u>
Castec Construction, LLC	Concrete paving	\$1,236,723.96	14%
Alamo Ready Mix, LLC.	Ready mix concrete	\$795,036.83	9%
H & E Aggregate, LLC.	Cement stabilization sand	\$530,024.55	6%
C.M. Nunez Trucking	Dump trucking	\$353,349.70	4%
Rebar Supply Company, Ltd.	Fabricated structural steel	\$176,674.85	2%
Holes Incorporated	Concrete breaking/sawing	\$88,337.42	1%
	Total	\$3,180,147.31	36%

ISI Contracting, Inc. designated the below-named companies as its MBE and WBE subcontractors.

<u>Name</u>	<u>Type of Work</u>	<u>Dollar Amount</u>	<u>Percentage</u>
Access Data Supply, Inc.	Concrete aggregate	\$3,370,082.85	13.95%
Holes Incorporated	Sawing	\$1,693,496.83	7.01%
H & E Aggregate, LLC.	Stabilized base	\$1,157,182.57	4.79%
PMG Project Management Group	Concrete repairs	\$1,050,886.05	4.35%
Romar Unlimited Inc.	Trucking	\$623,284.14	2.58%
Republic Traffic Safety	Traffic Control	\$553,225.07	2.29%
	Total	\$8,448,157.51	34.97%

The Office of Business Opportunity will monitor these contracts.

Hire Houston First:

The proposed contracts require compliance with the City's "Hire Houston First" (HHF) ordinance that promotes economic opportunity for Houston businesses and supports job creation. In this case, the proposed contractors do not meet the requirements of Hire Houston First; no Hire Houston First firms were within three percent.

Pay or Play:

The proposed contracts require compliance with the City's "Pay or Play" ordinance regarding health benefits for employees of City contractors. In this case, Main Lane Industries, LTD. provides health benefits to eligible employees in compliance with City policy and ISI Contracting, Inc. has elected to pay into the Contractor Responsibility Fund and provide health benefits to eligible employees in compliance with City policy.

Fiscal Note:

Funding for this item is included in the FY 2017 Adopted Budget. Therefore, no Fiscal Note is required as stated in the Financial Policy Ord. 2014-1078.

John J. Gillespie, Chief Procurement Officer
Finance/Strategic Procurement Division

Department Approval Authority Signature

Estimated Spending Authority:

Department	FY 2017	Out Years	Total
Department of Public Works and Engineering	\$8,485,900.00	\$24,506,142.60	\$32,992,042.60

Amount of Funding:

\$32,992,042.60 – Dedicated Drainage & Street Renewal Fund (2310)

Contact Information:

NAME:	DEPARTMENT/DIVISION	PHONE
David Guernsey, Assistant Director	PWE	(832) 395-3640
Martin King, Division Manager	FIN/SPD	(832) 393-8705
Yesenia Chuca, Sr. Procurement Specialist	FIN/SPD	(832) 393-8727

ATTACHMENTS:

Description	Type
<u>OBO Documents - Main Lane Industries Ltd.</u>	Backup Material
<u>OBO Documents - ISI Contracting Inc.</u>	Backup Material
<u>Form A - Fair Campaign Ordinance - Main Lane Industries Ltd.</u>	Backup Material
<u>Form A - Fair Campaign Ordinance - ISI Contracting Inc.</u>	Backup Material
<u>Form B - Fair Campaign Ordinance - ISI Contracting Inc. and Main Lane Industries Ltd.</u>	Backup Material
<u>Tax Report - Main Lane Industries Ltd.</u>	Backup Material
<u>Tax Report - ISI Contracting Inc.</u>	Backup Material
<u>Affidavit of Ownership - Main Lane Industries Ltd.</u>	Backup Material
<u>Affidavit of Ownership - ISI Contracting Inc.</u>	Backup Material
<u>Ordinance</u>	Ordinance/Resolution/Motion
<u>PWE Sign Off</u>	Backup Material
<u>Funding - Table A</u>	Backup Material
<u>Contract 1 of 2 - Main Lane Industries Ltd</u>	Backup Material
<u>Contract 2 of 2 - Main Lane Industries Ltd</u>	Backup Material
<u>Contract 1 of 2 - ISI Contracting Inc</u>	Backup Material
<u>Contract 2 of 2 - ISI Contracting Inc</u>	Backup Material



CITY OF HOUSTON - CITY COUNCIL

Meeting Date: 10/25/2016

ALL

Item Creation Date: 9/20/2016

20KMN01 Contract Award/ISI

Agenda Item#: 42.

Summary:

ORDINANCE appropriating \$1,395,253.50 out of Street & Traffic Control and Storm Drainage DDSRF Fund; awarding contract to **ISI CONTRACTING, INC** for On-Call Neighborhood Traffic Management Program Construction contract; setting a deadline for the bidder's execution of the contract and delivery of all bonds, insurance, and other required contract documents to the City; holding the bidder in default if it fails to meet the deadlines; providing funding for contingencies and engineering and testing services relating to construction of facilities financed by the Street & Traffic Control and Storm Drainage DDSRF Fund

Background:

SUBJECT: Contract Award for On-Call Neighborhood Traffic Management Program Construction. WBS No. N-320660-0024-4.

RECOMMENDATION: (Summary) Accept low bid, award construction Contract to ISI Contracting, Inc., and appropriate funds.

PROJECT NOTICE/JUSTIFICATION: This project is to construct traffic calming devices such as traffic circles, speed cushions, entrance/exit islands, directional islands and bulb-out islands in various locations throughout the City of Houston. Signing and pavement markings may also be required to accompany these devices.

DESCRIPTION/SCOPE: This project consists of construction of traffic calming devices along with necessary signing and pavement markings in various neighborhoods throughout the City of Houston. The Contract duration for this project is 730 calendar days. This is a work order based contract with projects assigned on an as-needed basis.

LOCATION: The work will be City wide.

BIDS: This project was advertised for bidding on April 29, 2016 and May 6, 2016. Bids were received on May 19, 2016. The four (4) bids are as follows:

	<u>Bidder</u>	<u>Bid Amount</u>
1.	ISI Contracting, Inc.	\$1,275,937.50
2.	DG Medina Construction, LLC	\$1,315,356.00
3.	Ally General Solutions, LLC	\$1,385,647.50

4.	Main Lane Industries, LTD	\$1,389,675.00
----	---------------------------	----------------

AWARD: It is recommended that this construction contract be awarded to ISI Contracting, Inc. with a low bid of \$1,275,937.50.

PROJECT COST: The total cost of this project is \$1,395,253.50 to be appropriated as follows:

·	Bid Amount	\$1,275,937.50
·	Contingencies	\$89,316.00
·	Engineering and Testing Services	\$30,000.00

Engineering and Testing Services will be provided by A & R Engineering and Testing, Inc. under a previously approved contract.

HIRE HOUSTON FIRST: The proposed contract requires compliance with the City's 'Hire Houston First' ordinance that promotes economic opportunity for Houston business and supports job creation. In this case the proposed contractor meets the requirements of Hire Houston First.

PAY OR PLAY PROGRAM: The proposed contract requires compliance with the City's 'Pay or Play' ordinance regarding health benefits for employees of City contractors. In this case, the contractor provides benefits for some employees but will pay into the Contractor Responsibility Fund for others, in compliance with City policy.

MWBE PARTICIPATION: The low bidder has submitted the following proposed program to satisfy the 11% MBE goal, and 7 % WBE goal for this project.

<u>MBE – Name of Firm</u>	<u>Work Description</u>	<u>Amount</u>	<u>% of Contract</u>
Republic Traffic Supply, Inc.	Traffic Signs	\$35,088.28	2.75%
Access Data Supply, Inc.	Construction Materials and Striping	\$105,775.22	8.29%
	MBE SUBTOTAL	\$140,863.50	11.04%
<u>WBE – Name of Firm</u>	<u>Work Description</u>	<u>Amount</u>	<u>% of Contract</u>
H&E Aggregate, LLC	Trucking & Asphalt Materials	\$71,835.00	5.63%
	WBE SUBTOTAL	\$71,835.00	5.63%
<u>SBE – Name of Firm</u>	<u>Work Description</u>	<u>Amount</u>	<u>% of Contract</u>
Houston Barricade & Supply, LLC	Type Of Service	\$35,088.28	2.75%
	SBE SUBTOTAL	\$35,088.28	2.75%
	TOTAL	\$247,786.78	19.42%

Capital Project Information

See attached Form A(s)

Estimated Fiscal Operating Impact

Project WBS #	FY17	FY18	FY19	FY20	FY21	FY17-FY21 Total
---------------	------	------	------	------	------	--------------------

N-320660-0024-4	\$0	\$0	\$0	\$0	\$0	\$0
-----------------	-----	-----	-----	-----	-----	-----

No significant Fiscal Operating impact is anticipated as a result of this project.

Prior Council Action:

Amount of Funding:

\$1,395,253.50 from Fund No. 4042 – Street & Traffic Control and Storm Drainage DDSRF

Contact Information:

Khang Nguyen, P.E., PTOE

Phone: (832) 395-3008

Assistant Director

ATTACHMENTS:

Description

Signed RCA

Type

Signed Cover sheet

TO: Mayor via City Secretary REQUEST FOR COUNCIL ACTION

SUBJECT: Contract Award for On-Call Neighborhood Traffic Management Program Construction. WBS No. N-320660-0024-4	Page 1 of 3	Agenda Item #
--	-----------------------	----------------------

FROM: (Department or other point of origin): Department of Public Works and Engineering	Origination Date:	Agenda Date:
---	--------------------------	---------------------

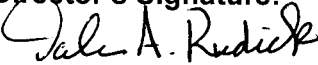
Director's Signature:  Dale A. Rudick, P.E.	Council District affected: ALL
--	--

For additional information contact:  Khang Nguyen, P.E., PTOE Phone: (832) 395-3008 Assistant Director	Date and identification of prior authorizing Council action:
--	---

RECOMMENDATION: (Summary)
Accept low bid, award construction Contract to ISI Contracting, Inc., and appropriate funds.

Amount and Source of Funding:
\$1,395,253.50 from Fund No. 4042 – Street & Traffic Control and Storm Drainage DDSRF
U.S.P. 9/16/16

PROJECT NOTICE/JUSTIFICATION: This project is to construct traffic calming devices such as traffic circles, speed cushions, entrance/exit islands, directional islands and bulb-out islands in various locations throughout the City of Houston. Signing and pavement markings may also be required to accompany these devices.

DESCRIPTION/SCOPE: This project consists of construction of traffic calming devices along with necessary signing and pavement markings in various neighborhoods throughout the City of Houston. The Contract duration for this project is 730 calendar days. This is a work order based contract with projects assigned on an as-needed basis.

LOCATION: The work will be City wide.

BIDS: This project was advertised for bidding on April 29, 2016 and May 6, 2016. Bids were received on May 19, 2016. The four (4) bids are as follows:

	<u>Bidder</u>	<u>Bid Amount</u>
1.	ISI Contracting, Inc.	\$1,275,937.50
2.	D G. Medina Construction, LLC	\$1,315,356.00
3.	Ally General Solutions, LLC	\$1,385,647.50
4.	Main Lane Industries, LTD	\$1,389,675.00

LTS No. 16026 **CUIC ID #20KMN01**

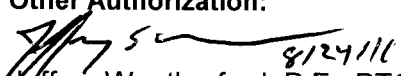
Finance Department:	Other Authorization:	Other Authorization:  Jeffrey Weatherford, P.E., PTOE Deputy Director Traffic Operations Division
----------------------------	-----------------------------	--

Date	Subject: Contract Award for On-Call Neighborhood Traffic Management Program Construction. WBS No. N-320660-0024-4	Originator's Initials	Page 2 of 2
-------------	--	------------------------------	--------------------

AWARD: It is recommended that this construction contract be awarded to ISI Contracting, Inc. with a low bid of \$1,275,937.50.

PROJECT COST: The total cost of this project is \$1,395,253.50 to be appropriated as follows:

- Bid Amount \$1,275,937.50
- Contingencies \$ 89,316.00
- Engineering and Testing Services \$ 30,000.00

Engineering and Testing Services will be provided by A & R Engineering and Testing, Inc. under a previously approved contract.

HIRE HOUSTON FIRST:

The proposed contract requires compliance with the City's 'Hire Houston First' ordinance that promotes economic opportunity for Houston business and supports job creation. In this case the proposed contractor meets the requirements of Hire Houston First.

PAY OR PLAY PROGRAM:

The proposed contract requires compliance with the City's 'Pay or Play' ordinance regarding health benefits for employees of City contractors. In this case, the contractor provides benefits for some employees but will pay into the Contractor Responsibility Fund for others, in compliance with City policy.

M/WBE PARTICIPATION: The low bidder has submitted the following proposed program to satisfy the 11% MBE goal, and 7 % WBE goal for this project.

<u>MBE - Name of Firms</u>	<u>Work Description</u>	<u>Amount</u>	<u>% of Contract</u>
1. Republic Traffic Safety, Inc.	Traffic Signs	\$ 35,088.28	2.75%
2. Access Data Supply, Inc.	Construction Materials & Striping	\$ 105,775.22	8.29%
	MBE Subtotal	\$ 140,863.50	11.04%

<u>WBE - Name of Firm</u>	<u>Work Description</u>	<u>Amount</u>	<u>% of Contract</u>
1. H & E Aggregate, LLC	Trucking & Asphalt Materials	\$ 71,835.00	5.63%
	WBE Subtotal	\$ 71,835.00	5.63%

<u>SBE - Name of Firm</u>	<u>Work Description</u>	<u>Amount</u>	<u>% of Contract</u>
1. Houston Barricade & Supply, LLC	Type of Service	\$ 35,088.28	2.75%
	SBE Subtotal	\$ 35,088.28	2.75%

TOTAL \$ 247,786.78 19.42%

Capital Project Information
See attached Form A(s)

Estimated Fiscal Operating Impact

Project WBS #	FY17	FY18	FY19	FY20	FY21	FY17-FY21 Total
N-320660-0024-4	\$0	\$0	\$0	\$0	\$0	\$0

No significant Fiscal Operating impact is anticipated as a result of this project.



CITY OF HOUSTON - CITY COUNCIL

Meeting Date: 10/25/2016

ALL

Item Creation Date: 10/11/2016

20PUD37 Contract Award/Coastal Water Authority

Agenda Item#: 43.

Summary:

ORDINANCE appropriating \$1,938,410.00 out of Water & Sewer System Consolidated Construction Fund for installation of a Main Canal Radial Gate Bypass supplying raw water to the City of Houston under contract awarded by Coastal Water Authority to **BRH GARVER CONSTRUCTION, L.P.** pursuant to an operating contract with the Coastal Water Authority (as approved by Ordinance No. 1995-676)

Background:

SUBJECT: Contract Award for Installation of Main Canal Radial Gate Bypass supplying raw water to the City of Houston and operated by the Coastal Water Authority. WBS: S-000019-0094-7.

RECOMMENDATION: (Summary) Accept low bid, award construction contract, and appropriate funds.

PROJECT NOTICE/JUSTIFICATION: The Coastal Water Authority (CWA) operates the raw surface water transportation system for the City of Houston (City) and provides conveyance for many governmental and industrial users. The radial gate structure located at CWA's Canal Maintenance Station controls the flow of water going downstream to the Lynchburg Reservoir and also maintains adequate water surface levels to supply the headwaters of the Cedar Point Lateral system that supplies industrial and agricultural customers. Based on previous inspections, the radial gate is in need of repairs to extend its useful life, or may need to be replaced. However, the radial gate cannot be taken out of service for inspection, repairs, or servicing due to downstream customers requiring uninterrupted water supply.

The City and CWA are parties to an Operating Contract dated June 21, 1995 (Operating Contract), approved by City Ordinance 95-676. The Operating Contract at Article II, Section 202 states, in part, that "the Public Works Director may request the Authority to ...make major renovations or repairs of City Projects which will not be financed with the proceeds of bonds or other obligations of the Authority. Upon such request, the Authority shall prepare for the City a proposal and a proposed budget for the Capital Project. The Authority shall not commence implementation of any Capital Project until: (a) the proposal has been accepted by the Public Works Director; and (b) the City Council has approved the Capital Project and has appropriated sufficient moneys to fund the Capital Project."

CWA obtained proposals from qualified contractors and recommends awarding the contract to the

low bidder, BRH Garver Construction L.P., in the amount of \$1,726,000.00.

This project was identified in the 2016 CWA budget submitted by the Department of Public Works and Engineering as part of the FY17 Department Budget that City Council approved in June 2016. The Department is now requesting that City Council approve the project and appropriate funding for \$1,938,410.00, so that CWA can commence the project.

DESCRIPTION/SCOPE: A bypass gate structure has been proposed at the lateral canal extending to the Cedar Point area of southwest Chambers County that will allow the radial gate to be isolated for inspection and needed repairs or replacement. The project includes furnishing labor, equipment, and materials to construct a 500 MGD canal bypass in the form of double barrel reinforced cast in place concrete box culverts, a reinforced concrete intake, and outlet structures. The duration of this project is 270 calendar days from the issuance of a notice to proceed.

LOCATION: The project area is located to the Southwest of SH146 along the CWA Maintenance Station Access Road in Dayton, TX. The project is located in Key Map Grid 422.

BIDS:

This project followed procurement practices consistent with CWA's bid guidelines. Six (6) bids were received on July 22, 2016 for this project as follows:

<u>Bidder:</u>	<u>Bid Amount</u>
1. BRH-Garver Construction, L.P.	\$1,726,000.00
2. Allco	\$1,438,860.00 (Non-responsive: No proposed MBE)
3. MK Constructors	\$1,599,000.00 (Non-responsive: No proposed MBE)
4. Lecon, Inc.	\$2,720,000.00
5. Oscar Renda Contracting	\$3,777,700.00
6. Boyer, Inc.	\$3,828,447.00

- AWARD: It is recommended that this construction contract be awarded to BRH-Garver Construction, L.P. with a bid of \$1,726,000.

- PROJECT COST:

The total cost of the project is \$1,938,410.00 to be appropriated as follows:

· Bid Amount:	\$1,726,000.00
· Construction Management:	\$126,110.00
· Contingency:	\$86,300.00

- Construction Management Services will be provided Lockwood, Andrews & Newman under a previously approved contract.

HIRE HOUSTON FIRST: The proposed contract is between CWA and BRH Garver Construction L.P., therefore, it does not require compliance with the City's Hire Houston First program.

PAY OR PLAY PROGRAM: The proposed contract is between CWA and the lowest bidder, therefore, it does not require compliance with the City's Pay or Play ordinance regarding health benefits for employees of City contractors.

MWSBE PARTICIPATION: The contractor has submitted the following proposed program to satisfy the 19% MBE goal for this project.

<u>MBE - Name of Firms</u> <u>% of Contract</u>	<u>Work Description</u>	<u>Amount</u>
XD Ventures \$23,458.00 1.36%	Fuel Supply	
Nerie Construction LLC .00 2.03%	Sewer Construction	\$35,000
P.A. Berrios Trucking \$42,687.00 2.47%	Trucking	
Texas Concrete \$81,000.00 4.69%	Ready Mix	
Fabco \$55,000.00 3.19%	Rebar Supply	
KMA Contractor's Services \$96,441.00 5.59%	Durable Goods	
Total MBE Participation 19.33%		\$333,586.00

ESTIMATED FISCAL OPERATING IMPACT:

PROJECT WBS#	FY17	FY18	FY19	FY20	FY21	FY17-FY21 Total
S-0000190- 0094-7	\$0.00	\$0.00	\$0.00	\$0.00	\$0.00	\$0.00

No significant Fiscal Operating impact is anticipated as a result of this project.

Prior Council Action:

Ordinance 1995-0676, dated 06/21/1995

Amount of Funding:

\$1,938,410.00 from Water and Sewer System Consolidated Construction Fund No. 8500.

Contact Information:

Yvonne Forrest
Senior Assistant Director
Phone: (832) 395-2847

ATTACHMENTS:

Description

Signed RCA

Type

Signed Cover sheet

TO: Mayor via City Secretary

REQUEST FOR COUNCIL ACTION

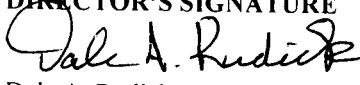
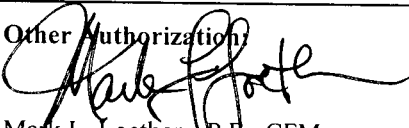
SUBJECT: Contract Award for Installation of Main Canal Radial Gate Bypass supplying raw water to the City of Houston and operated by the Coastal Water Authority. WBS: S-000019-0094-7		Page 1 of 2	Agenda Item #
FROM (Department or other point of origin): Department of Public Works and Engineering		Origination Date	Agenda Date
DIRECTOR'S SIGNATURE  Dale A. Rudick, P.E.		Council District affected: All	
For additional information contact: Yvonne Forrest Senior Assistant Director Phone: (832) 395-2847		Date and identification of prior authorizing Council action: Ordinance #95-676 dated Jun 21, 1995	
RECOMMENDATION: (Summary) Accept low bid, award construction contract, and appropriate funds.			
Amount and Source of Funding: \$1,938,410.00 from Water and Sewer System Consolidated Construction Fund No. 8500.			
PROJECT NOTICE/JUSTIFICATION: <i>W.P. 10/12/2016</i> The Coastal Water Authority (CWA) operates the raw surface water transportation system for the City of Houston (City) and provides conveyance for many governmental and industrial users. The radial gate structure located at CWA's Canal Maintenance Station controls the flow of water going downstream to the Lynchburg Reservoir and also maintains adequate water surface levels to supply the headwaters of the Cedar Point Lateral system that supplies industrial and agricultural customers. Based on previous inspections, the radial gate is in need of repairs to extend its useful life, or may need to be replaced. However, the radial gate cannot be taken out of service for inspection, repairs, or servicing due to downstream customers requiring uninterrupted water supply. The City and CWA are parties to an Operating Contract dated June 21, 1995 (Operating Contract), approved by City Ordinance 95-676. The Operating Contract at Article II, Section 202 states, in part, that "the Public Works Director may request the Authority to ... make major renovations or repairs of City Projects which will not be financed with the proceeds of bonds or other obligations of the Authority. Upon such request, the Authority shall prepare for the City a proposal and a proposed budget for the Capital Project. The Authority shall not commence implementation of any Capital Project until: (a) the proposal has been accepted by the Public Works Director; and (b) the City Council has approved the Capital Project and has appropriated sufficient moneys to fund the Capital Project." CWA obtained proposals from qualified contractors and recommends awarding the contract to the low bidder, BRH Garver Construction L.P., in the amount of \$1,726,000.00. This project was identified in the 2016 CWA budget submitted by the Department of Public Works and Engineering as part of the FY17 Department Budget that City Council approved in June 2016. The Department is now requesting that City Council approve the project and appropriate funding for \$1,938,410.00, so that CWA can commence the project.			
DESCRIPTION/SCOPE: A bypass gate structure has been proposed at the lateral canal extending to the Cedar Point area of southwest Chambers County that will allow the radial gate to be isolated for inspection and needed repairs or replacement. The project includes furnishing labor, equipment, and materials to construct a 500 MGD canal bypass in the form of double barrel reinforced cast in place concrete box culverts, a reinforced concrete intake, and outlet structures. The duration of this project is 270 calendar days from the issuance of a notice to proceed.			
LTS No. 16218		REQUIRED AUTHORIZATION	
CUIC# 20PUD37		Finance Department	
Other Authorization:		Other Authorization  Mark L. Loethen, P.E., CFM Acting Deputy Director Public Utilities Division	

Date	Subject: Contract Award for Installation of Main Canal Radial Gate Bypass supplying raw water to the City of Houston and operated by the Coastal Water Authority. WBS: S-000019-0094-7	Originator's Initials	Page 2 of 2
-------------	---	------------------------------	-----------------------

LOCATION:

The project area is located to the Southwest of SH146 along the CWA Maintenance Station Access Road in Dayton, TX. The project is located in Key Map Grid 422.

BIDS:

This project followed procurement practices consistent with CWA's bid guidelines. Six (6) bids were received on July 22, 2016 for this project as follows:

<u>Bidder:</u>	<u>Bid Amount</u>
1. BRH-Garver Construction, L.P.	\$1,726,000.00
2. Allco	\$1,438,860.00 (Non-responsive: No proposed MBE)
3. MK Constructors	\$1,599,000.00 (Non-responsive: No proposed MBE)
4. Lecon, Inc.	\$2,720,000.00
5. Oscar Renda Contracting	\$3,777,700.00
6. Boyer, Inc.	\$3,828,447.00

AWARD: It is recommended that this construction contract be awarded to BRH-Garver Construction, L.P. with a bid of \$1,726,000.00

PROJECT COST:

The total cost of the project is \$1,938,410.00 to be appropriated as follows:

• Bid Amount:	\$1,726,000.00
• Construction Management:	\$126,110.00
• Contingency:	\$86,300.00

Construction Management Services will be provided Lockwood, Andrews & Newman under a previously approved contract.

HIRE HOUSTON FIRST: The proposed contract is between CWA and BRH Garver Construction L.P., therefore, it does not require compliance with the City's Hire Houston First program.

PAY OR PLAY PROGRAM: The proposed contract is between CWA and the lowest bidder, therefore, it does not require compliance with the City's Pay or Play ordinance regarding health benefits for employees of City contractors.

M/WSBE PARTICIPATION: The contractor has submitted the following proposed program to satisfy the 19% MBE goal for this project.

<u>MBE - Name of Firms</u>	<u>Work Description</u>	<u>Amount</u>	<u>% of Contract</u>
XD Ventures	Fuel Supply	\$23,458.00	1.36%
Nerie Construction LLC	Sewer Construction	\$35,000.00	2.03%
P.A. Berrios Trucking	Trucking	\$42,687.00	2.47%
Texas Concrete	Ready Mix	\$81,000.00	4.69%
Fabco	Rebar Supply	\$55,000.00	3.19%
KMA Contractor's Services	Durable Goods	\$96,441.00	5.59%
Total MBE Participation		\$333,586.00	19.33%

ESTIMATED FISCAL OPERATING IMPACT:

<u>PROJECT WBS#</u>	<u>FY17</u>	<u>FY18</u>	<u>FY19</u>	<u>FY20</u>	<u>FY21</u>	<u>FY17-FY21 Total</u>
S-0000190-0094-7	\$0.00	\$0.00	\$0.00	\$0.00	\$0.00	\$0.00

No significant Fiscal Operating impact is anticipated as a result of this project.



CITY OF HOUSTON - CITY COUNCIL

Meeting Date: 10/25/2016

District B

Item Creation Date: 10/17/2016

PRD - Motion to set date for a public hearing on proposal to convey an easement in Keith-Wiess Park for a storm sewer outfall for the Aldine Town Center Project

Agenda Item#: 44.

Summary:

SET A PUBLIC HEARING DATE regarding a proposal to convey an easement in Keith-Wiess Park for Storm Sewer Outfall related to the Aldine Town Center Project - **DISTRICT B - DAVIS HEARING DATE - WEDNESDAY - 9:00 A.M. - NOVEMBER 30, 2016**

Background:

The East Aldine District (the District) has requested to use a 21,207 square foot area (0.4868 acre) of Keith-Wiess Park for storm sewer outfall related to the Aldine Town Center project (the Project).

The Houston Parks and Recreation Department (HPARD) supports this request as it will provide a public benefit by opening access to the park for residents to the north. The multi-use development project will include a roadway and trail connections to the park.

Texas Parks and Wildlife Code Chapter 26 requires the City to publish three public notices and hold a public hearing prior to authorizing the use or taking of park land for non-park purposes. Notices will be published in the Houston Chronicle on November 9, November 16 and November 23, 2016. The proposed date of the public hearing is Wednesday, November 30, 2016 at 9:00 a.m. in Council Chambers, Second Floor, City Hall, 901 Bagby, Houston, Texas.

HPARD will request Council action to approve an ordinance to make findings relating to the public hearing on December 7, 2016.

Director's Signature:

Joe Turner

Prior Council Action:

Not applicable

Amount of Funding:

Not applicable

Contact Information:

Luci Correa 832-395-7057

Luci.Correa@houstontx.gov

ATTACHMENTS:

Description

Signed RCA

Type

Signed Cover sheet



CITY OF HOUSTON - CITY COUNCIL

Meeting Date: 11/1/2016

District B

Item Creation Date: 10/17/2016

PRD - Motion to set date for a public hearing on proposal to convey an easement in Keith-Wiess Park for a storm sewer outfall for the Aldine Town Center Project

Background:

The East Aldine District (the District) has requested to use a 21,207 square foot area (0.4868 acre) of Keith-Wiess Park for storm sewer outfall related to the Aldine Town Center project (the Project).

The Houston Parks and Recreation Department (HPARD) supports this request as it will provide a public benefit by opening access to the park for residents to the north. The multi-use development project will include a roadway and trail connections to the park.

Texas Parks and Wildlife Code Chapter 26 requires the City to publish three public notices and hold a public hearing prior to authorizing the use or taking of park land for non-park purposes. Notices will be published in the Houston Chronicle on November 9, November 16 and November 23, 2016.

The proposed date of the public hearing is Wednesday, November 30, 2016 at 9:00 a.m. in Council Chambers, Second Floor, City Hall, 901 Bagby, Houston, Texas.

HPARD will request Council action to approve an ordinance to make findings relating to the public hearing on December 7, 2016.

Director's Signature:

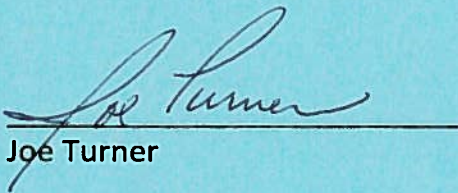

Joe Turner

Prior Council Action:

Not applicable

Amount of Funding:

Not applicable

Contact Information:

Luci Correa 832-395-7057

Luci.Correa@houstontx.gov