

Approved Parcel Drawing - Parcels SY17-045 and SY17-051

Abandonment and sale of Felix Street, from Harrisburg Street south to its terminus, located within the Harrisburg Market Subdivision.

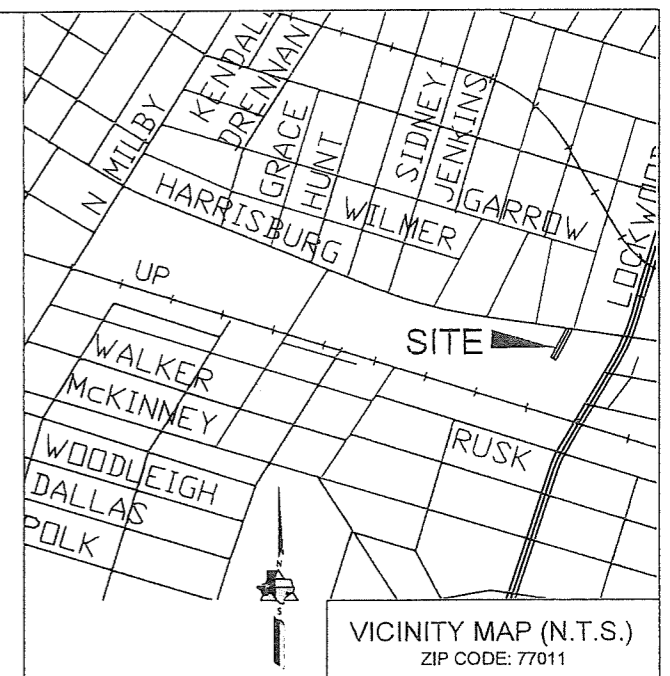
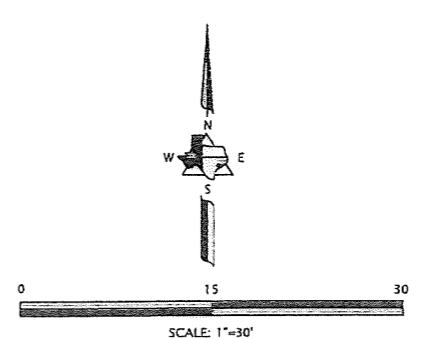
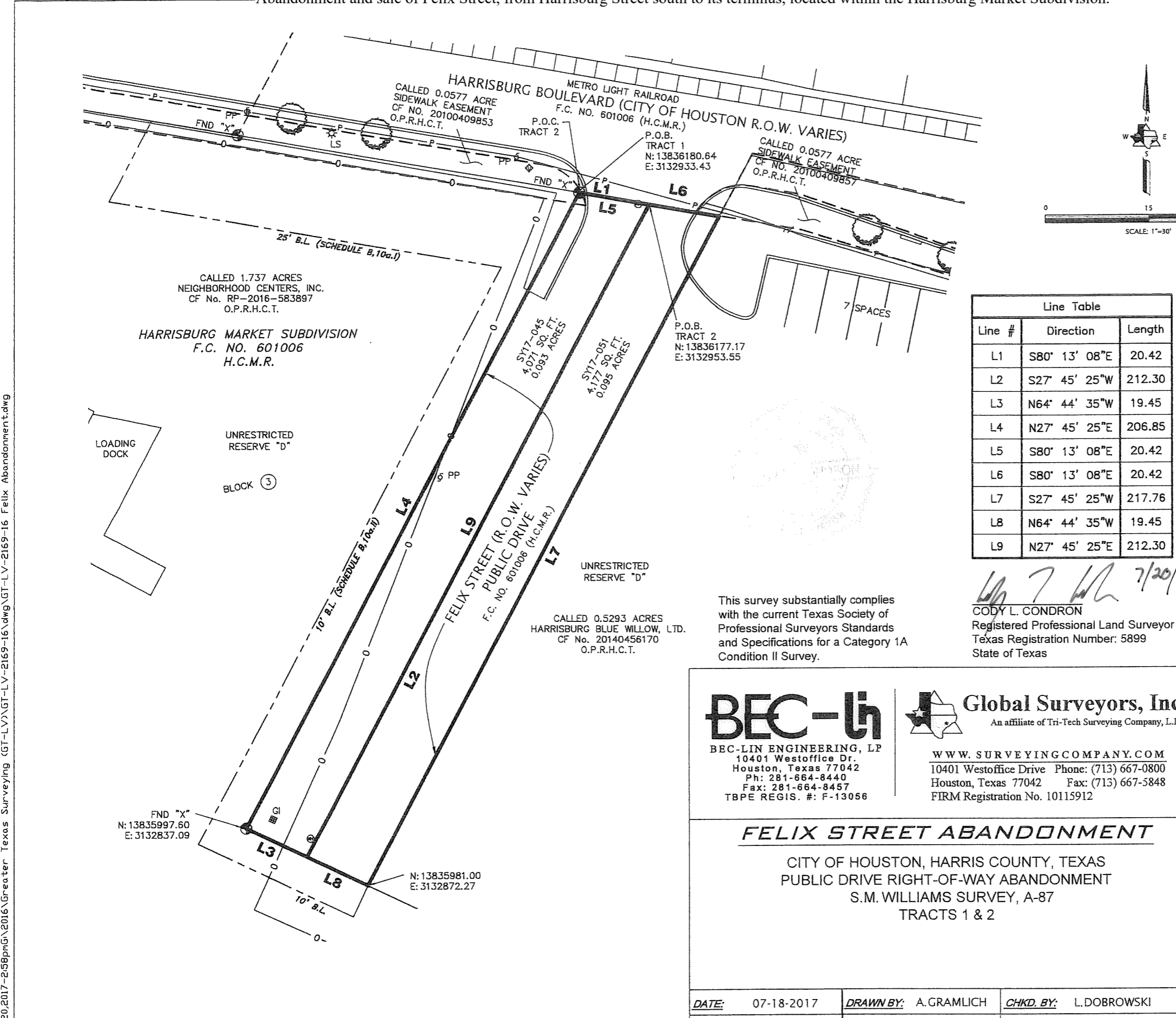

Line Table		
Line #	Direction	Length
L1	S80° 13' 08"E	20.42
L2	S27° 45' 25"W	212.30
L3	N64° 44' 35"W	19.45
L4	N27° 45' 25"E	206.85
L5	S80° 13' 08"E	20.42
L6	S80° 13' 08"E	20.42
L7	S27° 45' 25"W	217.76
L8	N64° 44' 35"W	19.45
L9	N27° 45' 25"E	212.30

NOTES:

1. ALL BEARINGS AND COORDINATES SHOWN HEREON ARE GRID WITH DISTANCES BEING TRUE BASED UPON TEXAS STATE PLANE COORDINATE SYSTEM SOUTH CENTRAL ZONE (4204). THE COMBINED SCALE FACTOR BETWEEN GRID AND SURFACE IS 0.99988671934.
2. SEE EXHIBIT "A" FOR METES AND BOUNDS DESCRIPTIONS (PAGES 2-3 OF 3)

This survey substantially complies with the current Texas Society of Professional Surveyors Standards and Specifications for a Category 1A Condition II Survey.

Cody L. Condron
 CODY L. CONDRON
 Registered Professional Land Surveyor
 Texas Registration Number: 5899
 State of Texas

BEC-LH
 BEC-LIN ENGINEERING, LP
 10401 Westoffice Dr.
 Houston, Texas 77042
 Ph: 281-664-8440
 Fax: 281-664-8457
 TBPE REGIS. #: F-13056

Global Surveyors, Inc.
 An affiliate of Tri-Tech Surveying Company, L.P.
 www.surveyingcompany.com
 10401 Westoffice Drive Phone: (713) 667-0800
 Houston, Texas 77042 Fax: (713) 667-5848
 FIRM Registration No. 10115912

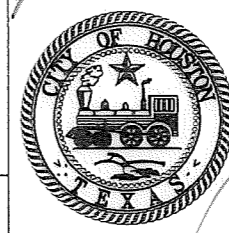

**CITY OF HOUSTON
 PUBLIC WORKS AND
 ENGINEERING DEPARTMENT**

APPROVAL

[Signature]

7/29/17
 DATE

[Signature]

SURVEY SECTION

RIGHT OF WAY SECTION

KEY MAP No. 494T

GIMS MAP No. 5456b

PARCEL NOS.

SY17-045

SY17-051

JOB NO.

WBS NO.

C.M. NO.

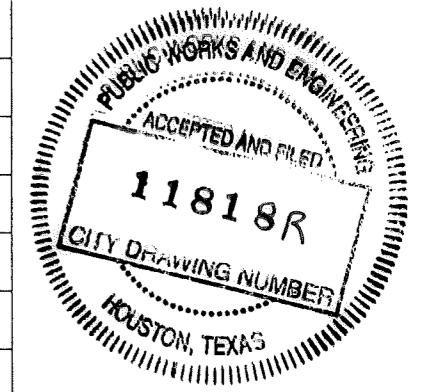

FELIX STREET ABANDONMENT
 CITY OF HOUSTON, HARRIS COUNTY, TEXAS
 PUBLIC DRIVE RIGHT-OF-WAY ABANDONMENT
 S.M. WILLIAMS SURVEY, A-87
 TRACTS 1 & 2

DATE: 07-18-2017	DRAWN BY: A.GRAMLICH	CHKD. BY: L.DOBROWSKI
SCALE: 1" = 30'	JOB NO. GT-LV-2169-16	DWG. NAME: GT-LV-2169-16

Jul 20, 2017 - 2:58pm G:\2016\Greater Texas Surveying (GT-LV)\GT-LV-2169-16.dwg GT-LV-2169-16 Felix Abandonment.dwg