

Houston Amendments to the 2012 Uniform Plumbing Code



Adopted by Ord. No. 2015-____

Passed __/__/2015

Effective 01/01/2016

CHAPTER 1

DEFINITIONS

101.1 Title. ~~This document~~ These regulations shall be known as the "~~Uniform~~ City of Houston Plumbing Code," may be cited as such, and will be referred to herein as "this code."

The *City of Houston Construction Code* collectively includes this volume and certain other codes, pamphlets, specifications, and documents that are adopted in or by reference through the adopting ordinance, City of Houston Ordinance No. 2015-_____¹, which appears in the preamble of the building code.

101.4 ~~Conflicting Provisions Between Codes.~~ ~~Where the requirements within the jurisdiction of this plumbing code conflict with the requirements of the mechanical code, this code shall prevail. in any specific case, different provisions of the *City Code*, the building code, the electrical code, the mechanical code, the energy conservation code, the residential code, the fire code, and this code specify different materials, methods of construction, or other requirements, the most restrictive shall prevail.~~ In instances where the code, applicable standards, or the manufacturer's installation instructions conflict, the more stringent provisions shall prevail. Where there is a conflict between a general requirement and a specific requirement, the specific requirement shall prevail.

101.4.1 Residential Code. Plumbing for detached one- and two-family dwellings and multiple single-family dwellings (townhouses) not more than three stories high with separate means of egress and their accessory structures shall comply with the residential code. Plumbing for residential occupancies to which the residential code does not apply shall be governed by this code.

101.4.2 Energy Efficiency. The Energy Conservation Code and Chapter 11 of the residential code, and any amendments adopted as authorized by state law, constitute the energy efficiency/conservation codes of the jurisdiction.

101.4.3 Irrigation Systems. Irrigation systems shall comply with standards and specifications regarding the design, installation, and operation of such systems in accordance with Chapter 344 of the Texas Administrative Code, Chapter 1903 of the Texas Occupations Code and any rules adopted by the Texas Commission on Environmental Quality pursuant to Section 1903.053 of the Texas Occupations Code.

101.10 Appendices. The provisions in the appendices are intended to supplement the requirements of this code and shall not be considered part of this code unless formally adopted as such. Appendices A, B, C, I, K, and L, as amended by this jurisdiction, are hereby adopted and shall be incorporated into and made a part of this code.

¹ City Secretary shall insert number of adopting ordinance.

101.12 Exempt Installations. The provisions of this code shall not apply to: a) gas service mains from the street main to the meter, b) the installation of gas meters by the utility organization supplying gas, c) gas piping installations of the utility organization made on its own or public premises and part of the general gas supply and distribution for this jurisdiction and surrounding communities, or d) the installation of public sewers and public water distribution systems by this jurisdiction, its contractors, agents and employees.

101.13 Homeowners. In accordance with the Plumbing License Law, nothing in this code shall prevent any homeowner from installing and maintaining plumbing in a building owned and occupied by him as his homestead and done in compliance with the requirements of all applicable state adopted codes and ordinances of this jurisdiction. Such privilege does not grant the right to violate any of the provisions of this code or state adopted codes, nor is it to be construed as exempting any such property owner from obtaining a permit and paying the required fees therefor, except for work that is exempt from permitting under this code.

101.14 Basic principles. The general requirements of this code are enunciated as necessary principles for proper, basic environmental sanitation through properly designed, acceptably installed, and adequately maintained plumbing systems. The following principles shall serve to define the intent of this code:

Principle No. 1. All premises intended for human habitation, occupancy, or use shall be provided with a supply of potable water that is neither connected with unsafe water supplies nor subject to the hazards of backflow, backsiphonage, or back pressure due to dormant or inert periods.

Principle No. 2. Every building having plumbing fixtures installed and intended for human habitation, occupancy, or use and located on premises abutting on a street, alley, or easement in which there is a public sewer shall have a separate connection with such sewer. Where two or more buildings are located on one lot fronting 75 feet (22.9 m) or less on such street, alley, or easement and the lot is under one ownership, one sewer connection to the public main may be used for all buildings located thereon. On industrial tracts, apartment projects, or similar installations under one ownership where the sanitary sewers within the tract are maintained and operated by one owner, separate connections shall be made to the privately owned and maintained sewer, but only one connection need be made to the public sewer.

Principle No. 3. Each dwelling unit shall have not less than one water closet, one bathtub or shower, one lavatory, and one kitchen-type sink. Adequate 120°F (48°C) hot water shall be provided to the tub or shower, lavatory, and kitchen sink. All other structures for human occupancy or use on premises located within 300 feet (91.4 m) of a public sewer or having a private sewage-disposal system shall have adequate sanitary sewer facilities but in no case less than one water closet and one fixture for cleansing purposes.

Principle No. 4. Plumbing fixtures shall be made of smooth, nonabsorbent material, shall be free from concealed fouling surface, and shall be located in ventilated enclosures.

Principle No. 5. Each fixture directly connected to the drainage system shall be equipped with a water-seal trap.

Principle No. 6. No substance that will clog the pipes, produce explosive mixtures, destroy the pipes or their joints or will interfere unduly with the sewage disposal process shall be allowed to enter the building drainage system.

Principle No. 7. Proper protection shall be provided to prevent contamination of food, water, sterile goods, and similar materials by backflow of sewage. When necessary, the fixture, device, or appliance shall be connected indirectly with the building drainage system.

Principle No. 8. No water closet shall be located in a room or compartment that is not properly lighted and ventilated.

Principle No. 9. If water closets or other plumbing fixtures are installed in buildings located on premises where there is no public sewer available as determined by the provisions of all applicable ordinances, suitable provisions shall be made for disposing of the building sewage by a method of sewage treatment and disposal approved by the Authority Having Jurisdiction. On-site sewage disposal systems shall additionally comply with Chapter 366 of the Texas Health and Safety Code.

Principle No. 10. Where a plumbing drainage system may be subject to backflow of sewage, suitable provisions shall be made to prevent its overflow in the building.

Principle No. 11. Plumbing shall be installed with due regard to preservation of the strength of structural members and prevention of damage to walls and other surfaces through fixture usage.

Principle No. 12. Sewage or other waste from a plumbing system that may be deleterious to surface or subsurface waters shall not be discharged into the ground or into any waterway unless it has first been rendered innocuous through subjection to a form of treatment that is approved by the Authority Having Jurisdiction and that meets the standards established by law.

102.2.2 Stop Orders. Where work is being done contrary to the provisions of this code, the Authority Having Jurisdiction shall be permitted to order the work stopped by notice in writing served on persons engaged in the doing or causing such work to be done, and such persons shall forthwith stop work until authorized by the Authority Having Jurisdiction to proceed with the work.

At the time such stop order is issued, the person doing the work and the permit holder shall be given notice of a right to a hearing on the matter pursuant to Section 102.6 of this code. On request, such a hearing shall be held within three business days unless the permit holder or the person doing the work requests an extension of time. Any stop order that has been issued shall remain in effect pending any hearing requested on the matter, unless the stop order is withdrawn by the Authority Having Jurisdiction.

~~**102.2.5 Liability.** The Authority Having Jurisdiction charged with the enforcement of this code, acting in good faith and without malice in the discharge of the Authority Having Jurisdiction's duties, shall not thereby be rendered personally liable for damage that accrues to persons or property as a result of an act or by reason of an act or omission in the discharge of duties. A suit brought against the Authority Having Jurisdiction or employee because of such act or omission performed in the enforcement of provisions of this code shall be defended by legal counsel provided by this jurisdiction until final termination of such proceedings. Except as otherwise provided by law, the Authority Having Jurisdiction shall~~

not personally be liable for any act or omission arising out of any official action taken to implement and enforce the provisions of this code. Additionally, except as otherwise provided by law, the Authority Having Jurisdiction shall not be personally liable for any action or omission taken in the course and scope of employment. Where and to the extent consistent with the provisions of Article X of Chapter 2 of the *City Code*, this jurisdiction shall provide legal representation and indemnification for any suit brought against the Authority Having Jurisdiction because of acts or omissions performed in the enforcement of this code.

102.3 Board of Appeals. In order to hear and decide appeals of orders, decisions, or determinations made by the Authority Having Jurisdiction relative to the application and interpretations of this code, there shall be and is hereby created a Plumbing Code Review Board of Appeals consisting of seven members who are qualified by experience and training to pass upon matters pertaining to plumbing design, construction, and maintenance and the public health aspects of plumbing systems and who are not employees of the jurisdiction. The Authority Having Jurisdiction shall be an ex-officio member and shall act as secretary to said board but shall have no vote upon a matter before the board. ~~The Board of Appeals shall be appointed by the governing body and shall hold office at its pleasure.~~ The board shall adopt rules of procedure for conducting its business and shall render decisions and findings in writing to the appellant with a duplicate copy to the Authority Having Jurisdiction.

102.3.2 Composition. Each Board member, except the member in Position 7, shall be appointed by the Mayor and confirmed by the City Council. The Mayor shall designate a member to be chairman. Each of the seven positions shall be numbered:

1. Positions 1 and 2 shall be filled by professional engineers registered by the State of Texas who are actively engaged in the design of plumbing systems.
2. Positions 3 and 4 shall be filled by duly licensed master plumbers.
3. Position 5 shall be filled by a degreed engineer who is in the employ of a local gas utility company.
4. Position 6 shall be filled by a member at large.
5. Position 7 shall be filled by the chief plumbing inspector of this jurisdiction.

102.3.3 Terms of Office; Qualifications; Removal; Vacancy; Meetings. The terms of office for the appointees to Positions Nos. 1, 3, and 5 shall expire on the second day of January of odd-numbered years, and the terms of office for the appointees to Positions Nos. 2, 4, and 6 shall expire on the second day of January of even-numbered years; however, each member shall continue in office until his respective successor shall have been appointed and qualified. The adoption of this code shall not terminate the term of office of any person currently serving in any position on the Board.

In addition to other qualifications herein above required, each member of the Board shall be a citizen of the United States. All members of the Board other than the appointee to Position 6 shall be selected on the basis of their technical and professional qualifications.

Each member of the Board shall be subject to removal by the Mayor. Whenever any position on the Board becomes vacant by reason of death, resignation, or removal, the

vacancy shall be filled for the unexpired term of the member being replaced. The Mayor shall appoint, subject to confirmation by City Council, another qualified person to serve the unexpired term of the vacancy.

The Board shall hold meetings in this jurisdiction at times and places to be designated by the chairman, who is also authorized to call special meetings when deemed necessary. Each member of the Board shall receive \$50.00 for each meeting he attends at which a quorum is present; provided, however, those members who are employees of this jurisdiction will be paid only for those meetings they attend that are neither held during nor continue beyond their regular working hours. Members shall not be compensated for more than three meetings in any one calendar month.

102.3.4 Quorum. Four Board members present at any meeting shall constitute a quorum for the transaction of all business of said Board. A majority vote of the Board members present at any meeting constituting a quorum shall prevail.

102.3.5 Review of Action of Plumbing Inspectors. Disputes arising between plumbing inspectors and any person concerning the application of the provisions of this code to the installation of plumbing facilities to serve property of the person may be submitted to the Authority Having Jurisdiction. Any interested party (other than an inspector of this jurisdiction) who is dissatisfied with the decision of the Authority Having Jurisdiction on the matter may appeal that decision to the Board by making application therefor in writing to the Authority Having Jurisdiction.

The Authority Having Jurisdiction shall forward the application to the Board chairman. The Board chairman shall inform the applicant and the Authority Having Jurisdiction in writing of the date and time set for a hearing on the matter. If the applicant fails to appear at the hearing, either in person or by attorney, the dispute shall be decided against the applicant. Each party to the dispute shall be entitled to present his side of the matter to the Board, and the Board shall render its decision on the matter based upon its interpretation of the applicable provisions of this code. Any party to the dispute who is dissatisfied with the Board's decision shall have the right to appeal the decision to the City Council, by delivering a written notice of appeal to the office of the City Secretary within 10 days after the date of the Board's decision. The City Council shall affirm, reverse or modify the Board's decision based upon the City Council's interpretation of the applicable provisions of this code. The City Council's decision on the matter shall be final.

All appeals to the City Council are subject to the rules of the City Council, which are codified in Section 2-2 of the *City Code*, copies of which are available from the City Secretary. Parties wishing to preserve their right of appeal must comply with the rules of the City Council, including Rule 12.

102.3.6 Review of New Materials, Methods and Interpretations of this Code. Any person whose plumbing products are not specifically approved by this code may file a petition in writing for approval thereof with the Authority Having Jurisdiction, who shall determine whether the material or method should be approved pursuant to this code. If the Authority Having Jurisdiction denies approval of the material or method, the decision may be appealed to the Board. Such an appeal shall be by a petition delivered to the Authority Having Jurisdiction who in turn shall deliver the petition to the chairman of the Board. The Board shall, within 30 days after the date of filing of the petition, hear the petition and

determine the merits of the material or method. The Board may establish any additional tests to which the product must be subjected if the Board finds the tests necessary to determine whether the product should be approved. Any and all tests shall be made at the petitioner's expense, and the petitioner shall deposit the cost with this jurisdiction before the tests are made. If additional tests are required, the Board shall render its decision within 30 days after the tests are completed.

In the event the Board is of the opinion that the plumbing should be approved pursuant to Section 301.2 of this code, they shall so state in the minutes of the Board, and such plumbing shall be approved.

102.4 Violations. It shall be unlawful for a person, firm, or corporation to erect, construct, enlarge, alter, repair, move, improve, remove, convert, demolish, equip, use, or maintain plumbing or permit the same to be done in violation of this code. It shall be a violation to falsify any test required by this code.

102.5 Penalties. A person, firm, or corporation violating a provision of this code shall be deemed guilty of a misdemeanor, and upon conviction thereof, shall be punishable by a fine, imprisonment, or both set forth by the governing laws of the jurisdiction. Each separate day or portion thereof, during which a violation of this code occurs or continues, shall be deemed to constitute a separate offense. Where no specific penalty is otherwise provided in this code, the violation of any provision of this code shall constitute a misdemeanor punishable upon conviction by a fine of not less than \$500.00 nor more than \$2,000.00. Each day that any violation continues shall constitute and be punishable as a separate offense. Where any conduct in violation of this code also constitutes a violation of state penal law, then the offense shall be punishable as provided in the applicable state law. In prosecutions under this code, the various provisions hereof that are designated as an "exception" or "exceptions" shall not be treated as exceptions within the meaning of Section 2.02 of the Texas Penal Code, and instead, they shall constitute defenses to prosecution within the meaning of Section 2.03 of the Texas Penal Code.

102.6 Hearing Procedures

102.6.1 Hearing Notices. Whenever notice is to be given to any person concerning the right to a hearing, the notice may be given by personal delivery or by certified mail, return receipt requested. If notice is being given to a building owner or to a tenant therein, and the Authority Having Jurisdiction is unable to determine the name or address of such person after checking the building and the applicable records of the jurisdiction's Department of Public Works and Engineering, the County Appraisal District, the electrical utility company and the gas utility company, notice shall be mailed to the billing addresses of the building as shown on the records of the Water Division of the jurisdiction's Department of Public Works and Engineering and shall be posted on or in view of each entrance to the building. Additionally, if any notice is mailed to a building owner or a building tenant and is returned without delivery, notice shall be effective if posted on or in view of each entrance to the building.

102.6.2 Hearings. Except where otherwise specifically provided, all hearings held pursuant to this code shall be conducted by the director of the jurisdiction's Department of Public Works and Engineering or a representative, who shall hereinafter be referred to as the hearing official. The director shall not designate any person to be a hearing official under this code who has taken any part in the investigation of the matter that is the subject of the hearing or any person who directly supervised the investigation. The hearing official shall

consider only the evidence presented at the hearing in rendering a decision. The decision of the hearing official shall be set forth in writing and shall be served on each party in the same manner as a notice of a right to a hearing.

103.1.1 Exempt Work. A permit shall not be required for the following:

- (1) The stopping of leaks in drains, or soil, waste, or vent pipe, provided, however, that if a trap, drainpipe, or soil, waste, or vent pipe becomes defective and it becomes necessary to remove and replace the same with new material, the same shall be considered as new work and a permit shall be procured and inspection made as provided in this code.
- (2) The clearing of stoppages, including the removal and reinstallation of water closets, or the repairing of leaks in pipes, valves, or fixtures, provided such repairs do not involve or require the replacement or rearrangement of valves, pipes, or fixtures.

Exemption from the permit requirements of this code shall not be deemed to grant authorization for work to be done in violation of the provisions of the code or other laws or ordinances of this jurisdiction.

This section shall be construed in a manner that is consistent with the Plumbing License Law, and no provision herein shall be construed to exempt work for which a permit is required to be obtained from this jurisdiction under state law.

~~103.1.2 Licensing.~~ ~~Provision for licensing shall be determined by the Authority Having Jurisdiction.~~ **Irrigation Permit.** An installer of an irrigation system shall obtain a separate permit for each property before installing such a system.

103.2 Application for Permit. Upon application by a state-licensed master plumber or by a property owner of a building owned and occupied by him as his homestead to install storm and sanitary sewers, plumbing fixtures, appurtenances and appliances for drainage, gas, water and/or sewer lines, or medical gas, water treatment and/or irrigation lines and appurtenances, or by drain layer's license holders to install storm sewers, or by an installer of an irrigation system to install irrigation lines or systems, if the conditions and requirements of this code have been complied with and if there are adequate facilities or arrangements have been made to provide service to such plumbing installations, the Authority Having Jurisdiction shall issue a permit. No plumbing permit shall be issued until a building permit shall have first been issued where a building permit is required. To obtain a permit, the applicant shall first file an application therefore in writing on a form furnished by the Authority Having Jurisdiction for that purpose. Such application shall:

- (1) Identify and describe the work to be covered by the permit for which application is made.
- (2) Describe the land upon which the proposed work is to be done by legal description, street address, or similar description that will readily identify and definitely locate the proposed building or work.
- (3) Indicate the use or occupancy for which the proposed work is intended.
- (4) Be accompanied by plans, diagrams, computations, and other data in accordance with Section 103.2.1 and by the applicable fees as provided in the city fee schedule.
- (5) Be signed by the permittee or the permittee's authorized agent. The Authority Having

Jurisdiction shall be permitted to require evidence to indicate such authority.

- (6) Give such other data and information ~~in accordance with~~ as may reasonably be required by the Authority Having Jurisdiction.
- (7) Be accompanied by the applicable fees as provided in the city fee schedule.

103.3.2 Validity of Permit. The issuance of a permit or approval of plans and specifications shall not be construed to be a permit for, or an approval of, a violation of the provisions of this code or other ordinance of the jurisdiction. No permit presuming to give authority to violate or cancel the provisions of this code shall be valid.

The issuance of a permit based upon plans, specifications, or other data shall not prevent the Authority Having Jurisdiction from thereafter requiring the correction of errors in said plans, specifications, and other data or from preventing building operations being carried on thereunder where in violation of this code or of other ordinances of this jurisdiction.

A permit shall be valid only for work performed under the licensed master plumber who signed the application. A new permit must be obtained if the licensed master plumber who signed the application ceases to perform the work. The cost of the new permit shall be charged at the rate listed for the minimum fee stated in the city fee schedule. In the case of the death of the original licensed master plumber, the permit will be transferred to the new licensed master plumber at no fee except for the administrative fee established in the city fee schedule. Applicants who fail to re-permit any applicable work within the timeframes established by this code shall be subject to permit fees in the amount stated in the city fee schedule.

103.3.3 Expiration. ~~A Every permit issued shall become inactive by the Authority Having Jurisdiction under the provisions of this code shall expire by limitation and become null and void where the work authorized by such permit is not commenced within 180 days from the date of such permit, or where unless the work authorized by such permit is commenced within 180 days after its issuance, or if the work authorized on the site by such permit is suspended or abandoned at a time after the work is commenced for a period of 180 days after the time work is commenced. The building official is authorized to grant, in writing, one or more extensions of time, for periods not more than 180 days each. The extension shall be requested in writing and justifiable cause demonstrated. Before such work is recommenced, a new permit shall first be obtained to do so, and the fee therefore shall be one-half the amount required for a new permit for such work, provided no changes have been made or will be made in the original plans and specifications for such work, and provided further that such suspensions or abandonment has not exceeded 1 year.~~

~~—A permittee holding an unexpired permit shall be permitted to apply for an extension of the time within which work shall be permitted to commence under that permit where the permittee is unable to commence work within the time required by this section. The Authority Having Jurisdiction shall be permitted to extend the time for action by the permittee for a period not exceeding 180 days upon written request by the permittee showing that circumstances beyond the control of the permittee have prevented action from being taken. No permit shall be extended more than once. In order to renew action on a permit after expiration, the permittee shall pay a new full permit fee.~~

If work is not commenced under a permit within two years after the date of issuance or is abandoned at any time for a period of two years, the permit shall expire. In order to recommence work under an expired permit, the permit holder shall pay the full permit fee applicable and submit plans that comply with this code for the previously uninspected portion of the work.

Exception: For the purpose of issuing a certificate of compliance, the building official may, upon request, reactivate a *permit* and perform a final inspection of work.

103.3.4 Suspension or Revocation. After notice and a hearing pursuant to Section 102.6, the Authority Having Jurisdiction shall be permitted to, in writing, suspend or revoke a permit issued under the provisions of this code where the permit is issued in error or on the basis of incorrect information supplied or in violation of other ordinance or regulation of the jurisdiction.

~~**103.4 Fees.** Fees shall be assessed in accordance with the provisions of this section and as set forth in the fee schedule Table 103.4. The fees are to be determined and adopted by this jurisdiction. The fee for each permit shall be as set forth in the city fee schedule.~~

~~**103.4.1 Plan Review Fees.** Where a plan or other data is required to be submitted by Section 103.2.1, a plan review fee shall be paid at the time of submitting plans and specifications for review.~~

~~— The plan review fees for plumbing work shall be determined and adopted by this jurisdiction.~~

~~— The plan review fees specified in this subsection are separate fees from the permit fees specified in this section and are in addition to the permit fees.~~

~~— Where plans are incomplete or changed so as to require additional review, a fee shall be charged at the rate shown in Table 103.4.~~

103.4.2 Expiration of Plan Review. Applications for which no permit is issued within ~~180 days~~ 2 years following the date of application shall expire by limitation, and plans and other data submitted for review thereafter, shall be returned to the applicant or destroyed by the Authority Having Jurisdiction. The Authority Having Jurisdiction shall be permitted to ~~exceed~~ extend the time for action by the applicant for a period not to exceed 180 days upon request by the applicant showing that circumstances beyond the control of the applicant have prevented action from being taken. No application shall be extended more than once. In order to renew action on an application after expiration, the applicant shall resubmit plans ~~and pay a new plan review fee.~~

103.4.3 Investigation Fees—Work Without a Permit. Where work for which a permit is required by this code has been commenced without first obtaining said permit, a special investigation shall be made before a permit shall be issued for such work.

103.4.3.1 Fees. An investigation fee, in addition to the permit fee, shall be collected whether or not a permit is then or subsequently issued. The investigation fee shall be equal to the amount of the permit fee that is required by this code if a permit were to be issued. The payment of such investigation fee shall not exempt a person from compliance with other provisions of this code, nor from a penalty prescribed by law.

103.4.4 Fee Refunds. The Authority Having Jurisdiction shall be permitted to authorize the refunding of a fee paid hereunder that was erroneously paid or collected due to an error by one or more jurisdiction employees. This provision shall not be applicable if the error occurred due to incorrect information provided by the applicant.

103.4.4.1 Percentage. The Authority Having Jurisdiction shall be permitted to authorize the refunding of not more than ~~a percentage~~ 90 percent of the fee amount in excess of the minimum fee listed in the city fee schedule, as determined by this jurisdiction where no work has been done under a permit issued in accordance with this code. If work has been done under the permit, no refund shall be authorized. The administrative fee and plan review fees shall not be refunded.

103.4.5 Annual Fee Increase. Notwithstanding any maximum fee established pursuant to the City of Houston Construction Code, the fees in this or in any volume of the City of Houston Construction Code, as adjusted according to this section, shall be automatically increased on the first day of each subsequent calendar year as provided in Section 1-13 of the City Code.

103.5.9 Reinspections. A reinspection fee shall be permitted to be assessed for each inspection or reinspection where such portion of work for which inspection is called is not complete or where required corrections have not been made.

This provision is not to be interpreted as requiring reinspection fees the first time a job is rejected for failure to be in accordance with the requirements of this code, but as controlling the practice of calling for inspections before the job is ready for inspection or reinspection.

Reinspection fees shall be permitted to be assessed where the approved plans are not readily available to the inspector, for failure to provide access on the date for which the inspection is requested, or for deviating from plans requiring the approval of the Authority Having Jurisdiction.

To obtain reinspection, the applicant shall file an application therefore in writing upon a form furnished for that purpose and pay the reinspection fee in accordance with ~~Table 103.4~~ the city fee schedule.

In instances where reinspection fees have been assessed, no additional inspection of the work will be performed until the required fees have been paid.

104.0 Licensing

104.1 General. Before any person shall engage in the plumbing business within the jurisdiction, the person shall secure a state license as a master plumber, as required by the Texas State Board of Plumbing Examiners under the current Plumbing License Law. A master license holder shall annually register his/her state plumbing license with the Authority Having Jurisdiction during the month of initial registration. The Authority Having Jurisdiction shall not register a master plumber as a contractor until and unless the master plumber is listed on the Texas State Board of Plumbing Examiner's website.

No registration shall be effective at any time that the plumbing master fails to maintain current proof of insurance as required by state law.

104.2 License to do Plumbing Work. Each person engaged in the actual installation of plumbing shall be licensed either as a master or current journeyman plumber or registered as an apprentice by the Texas State Board of Plumbing Examiners under the Plumbing License Law. A licensed master plumber must have a medical gas endorsement to engage in the installation of medical gas.

104.3 Licensing of Drain Layers. Before any person other than a master plumber engages in the business of laying sanitary or storm sewers, the person shall make an application for and secure a drain layer's license. The application for and issuance of such license shall be in accordance with Chapter 47 of the *City Code*.

104.3.1 Registered Irrigators. Before any person other than a master plumber engages in the installation of lawn irrigation systems, the person shall obtain a certificate of registration (license) under state law and register with the Authority Having Jurisdiction. This requirement shall not extend to work that is exempt under this code and state law.

The annual fee for irrigator registration required in Section 104.3.1 is stated in the city fee schedule.

104.3.2 Certified Water Treatment Specialists. Before any person other than a master plumber engages in the business of installing water treatment equipment, the person must secure a State of Texas Water Treatment Specialist Certification under Chapter 341 of the Texas Health and Safety Code, and register the certification with the Authority Having Jurisdiction.

104.4 Illegal Work. Any person engaged in the plumbing or drain laying business whose work does not conform to this code, or whose workmanship or materials are of inferior quality, shall, upon notice from the Authority Having Jurisdiction, make necessary changes or corrections at once so as to conform to this code. If work has not been so changed 10 days after delivery of notice, the Authority Having Jurisdiction shall then refuse to issue any further permits to the person until the nonconforming work has been fully corrected in accordance with this code.

104.5 Allowing One's Name or License to Be Used to Obtain Permit Fraudulently. No person engaged in the business of plumbing or laying drains shall allow his name to be used by any other person, directly or indirectly, to obtain a permit.

104.6 Identification of Vehicles Required. Each person engaged in the plumbing business in the jurisdiction shall identify all vehicles used in the business with signs showing the name of the business and master plumber's license number. This information shall be correct at all times, shall be painted on each side of each vehicle and shall be in full view and legible at all times. Lettering shall be a minimum of 2 inches (50.8 mm) high.

**TABLE 103.4
PLUMBING PERMIT FEES
ADMINISTRATION**

Permit Issuance

- 1. For issuing each permit*
- 2. For issuing each supplemental permit*

Unit Fee Schedule (in addition to Items 1 and 2 above)

- 1. For each plumbing fixture on one trap or a set of fixtures on one trap (including water, drainage piping, and backflow protection therefore)*
- 2. For each building sewer and each trailer park sewer*
- 3. Rainwater systems per drain (inside building)*
- 4. For each cesspool (where permitted)*
- 5. For each private sewage disposal system*
- 6. For each water heater, vent, or both*
- 7. For each gas piping system of one to five outlets*
- 8. For each additional gas piping system outlet, per outlet*
- 9. For each industrial waste pretreatment intercepter, including its trap and vent, except kitchen type grease interceptors functioning as fixture traps*
- 10. For each installation, alteration, or repair of water piping, water treating equipment, or both*
- 11. For each repair or alteration of drainage or vent piping, each fixture*
- 12. For each lawn sprinkler system on one meter including backflow protection devices therefore*
- 13. For atmospheric type vacuum breakers not referenced in Item 12:
 - One to 5*
 - over 5, each*
- 14. For each backflow protective device other than atmospheric type vacuum breakers:
 - Two inch (50 mm) diameter and smaller*
 - over 2 inch (50 mm) diameter*
- 15. For each graywater system*
- 16. For initial installation and testing for a reclaimed water system*
- 17. For each annual cross connection testing of a reclaimed water system (excluding initial test)*
- 18. For each medical gas piping system serving one to five inlet(s)/outlet(s) for a specific gas*
- 19. For each additional medical gas inlet(s)/outlet(s)*

Other Inspections and Fees

- 1. Inspections outside of normal business hours*
- 2. Reinspection fee*
- 3. Inspections for which no fee is specifically indicated*
- 4. Additional plan review required by changes, additions, or revisions to approved plans (minimum charge ½ hour) . *

For SI units: 1 inch = 25 mm

*Jurisdiction will indicate their fees here.

CHAPTER 2

DEFINITIONS

Section 203.0

- A -

Authority Having Jurisdiction. ~~The jurisdiction's Director of the Department of Public Works and Engineering. The organization, office, or individual responsible for enforcing the requirements of a code or standard, or for approving equipment, materials, installations, or procedures. The Authority Having Jurisdiction shall be a federal, state, local, or other regional department or an individual such as a plumbing official, mechanical official, labor department official, health department official, building official, or others having statutory authority. In the absence of a statutory authority, the Authority Having Jurisdiction may be some other responsible party.~~ This definition shall include the Authority Having Jurisdiction's duly authorized representative.

Section 204.0

- B -

Bathroom. A room equipped with a shower, bathtub, or combination bath/shower.

Bathroom Group. ~~A group of fixtures consisting of a~~ Any combination of fixtures, not to exceed one water closet, ~~one or two~~ lavatories, ~~and either a~~ one bathtub, ~~a or one~~ combination bath/shower, ~~or a~~ and one shower, and may include a ~~urinal or~~ bidet and an emergency floor drain.

Building Code. The *City of Houston Building Code*, as adopted by this jurisdiction.

Section 205.0

- C -

City Code. The Code of Ordinances, Houston, Texas.

City Fee Schedule. The schedule of fees charged by the city for various permits, licenses, authorizations and services, which schedule is maintained on the city's website.

Section 206.0

- D -

Dry Vent. A vent that does not receive the discharge of any sewage or waste.

Section 207.0

- E -

Electrical Code. The *National Electrical Code* promulgated by the National Fire Protection Association, as adopted by this jurisdiction, and the *City of Houston Electrical Code*.

Energy Conservation Code. The *City of Houston Residential Energy Conservation Code* or the *City of Houston Commercial Energy Conservation Code*, both based on the *International Energy Conservation Code*, as adopted by the State of Texas, or on an alternate code that has been determined to be more stringent than the *International Energy Conservation Code*, as provided in Chapter 388 of the Texas Health & Safety Code, both as adopted and amended by this jurisdiction.

Section 208.0 - F -

Fire Code. The *City of Houston Fire Code*, as adopted by this jurisdiction.

Section 209.0 - G -

Gravity Grease Interceptor. A plumbing appurtenance or appliance that is installed in a sanitary drainage system to intercept nonpetroleum fats, oils, and greases (FOG) from a wastewater discharge and is identified by volume, 30 minute retention time, baffle(s), not less than two compartments, a total volume of not less than ~~300~~ 500 gallons (~~1135-1893~~ L), and gravity separation. [These interceptors comply with the requirements of Chapter 10 or are designed by a registered professional engineer.] Gravity grease interceptors are generally installed outside.

Section 210.0 - H -

Health Department. The Houston Health Department.

Section 214.0 - L -

~~**Lot.**—A single or individual parcel or area of land legally recorded or validated by other means acceptable to the Authority Having Jurisdiction on which is situated a building or which is the site of any work regulated by this code, together with the yards, courts, and unoccupied spaces legally required for the building or works, and that is owned by or is in the lawful possession of the owner of the building or works. A portion or parcel of land considered as a unit.~~

Section 215.0 - M -

Mechanical Code. The *City of Houston Mechanical Code*, as adopted by this jurisdiction.

Section 217.0 - O -

On-Site Treated Nonpotable Water. Nonpotable water, including gray water that has been collected, treated, and intended to be used on-site and is suitable for direct beneficial use. The level of treatment and quality shall be approved by the Texas Commission on Environmental Quality.

Section 218.0

- P -

Plumbing License Law. Chapter 1301 of the Texas Occupations Code.

Section 220.0

- R -

Reclaimed (Recycled) Water. Nonpotable water provided by a water/wastewater utility that, as a result of tertiary treatment of domestic wastewater, meets requirements of the public health ~~Authority Having Jurisdiction~~ for its intended uses. The level of treatment and quality of the on-site recycled water shall be approved by the Texas Commission on Environmental Quality.

Residential Code. The City of Houston Residential Code, based on the International Residential Code for One- and Two-Family Dwellings, as adopted by the State of Texas in Subchapter G of Chapter 214 of the Texas Local Government Code, with amendments adopted by this jurisdiction.

Section 223.0

- U -

Uniform Mechanical Code. The City of Houston Mechanical Code, as adopted by this jurisdiction.

Section 224.0

- V -

Vent. See Plumbing Vent; Dry Vent; Wet Vent.

CHAPTER 3

GENERAL REGULATIONS

301.2 Alternate Materials and Methods of Construction Equivalency. Nothing in this code is intended to prevent the use of systems, methods, or devices of equivalent or superior quality, strength, fire resistance, effectiveness, durability, and safety over those prescribed by this code. Technical documentation shall be submitted to the Authority Having Jurisdiction to demonstrate equivalency. The Authority Having Jurisdiction shall have the authority to approve or disapprove the system, method, or device for the intended purpose.

~~However, the exercise of this discretionary approval by the Authority Having Jurisdiction shall have no effect beyond the jurisdictional boundaries of said Authority Having Jurisdiction. An alternate material or method of construction so approved shall not be considered as in accordance with the requirements, intent, or both of this code for a purpose other than that granted by the Authority Having Jurisdiction where the submitted data does not prove equivalency.~~

~~301.3 Reserved—See Chapter 19 of the City Code. Flood Hazard Areas.~~

~~Plumbing systems shall be located above the elevation in accordance with the building code for utilities and attendant equipment or the elevation of the lowest floor, whichever is higher.~~

~~**Exception:** Plumbing systems shall be permitted to be located below the elevation in accordance with the building code for utilities and attendant equipment or the elevation of the lowest floor, whichever is higher, provided that the systems are designed and installed to prevent water from entering or accumulating within their components and the systems are constructed to resist hydrostatic and hydrodynamic loads and stresses, including the effects of buoyancy, during the occurrence of flooding to such elevation.~~

~~301.3.1 Flood Hazard Areas Subject to High-Velocity Wave Action.~~

~~Plumbing systems in buildings located in flood hazard areas subject to high velocity wave action shall be in accordance with the requirements of Section 301.3, and the plumbing systems, pipes, and fixtures shall not be mounted on or penetrate through walls that are intended to breakaway under flood loads in accordance with the building code.~~

319.2 Medical Gas Systems. The installation of medical gas systems shall be performed by certified installers meeting the requirements of the Texas Board of Plumbing Examiners.

CHAPTER 4

PLUMBING FIXTURES AND FIXTURE FITTINGS

403.2 Water Closets. Water closets, ~~either—whether~~ flush tank, flushometer tank, or flushometer valve operated, shall have an average consumption not to exceed ~~4.6~~ 1.28 gallons (~~6.1~~ 4.85 L) of water per flush or be a high efficiency fixture.

403.3 Urinals. Urinals shall have an average water consumption not to exceed ~~4~~ .5 gallon (~~4~~ 2 L) of water per flush.

403.4 Metered Faucets. Self-closing or self-closing metering faucets shall be installed on lavatories intended to serve the transient public, such as those in, but not limited to, service stations, train stations, airports, restaurants, and convention halls. Metered faucets shall deliver a maximum of ~~0.26~~ .25 gallons (~~0.98~~ 1.0 L) of water per use metering cycle.

Exception: When required by the health department to meet minimum temperature requirements.

~~**422.1 Fixture Count.** Plumbing fixtures shall be provided for the type of building occupancy and in the minimum number shown in Table 422.1. The total occupant load and occupancy classification shall be determined in accordance with the building code. Occupancy classification not shown in Table 422.1 shall be considered separately by the Authority Having Jurisdiction.~~

~~—The minimum number of fixtures shall be calculated at 50 percent male and 50 percent female based on the total occupant load. Where information submitted indicates a difference in distribution of the sexes such information shall be used in order to determine the number of fixtures for each sex. Once the occupancy load and occupancy are determined, Table 422.1 shall be applied to determine the minimum number of plumbing fixtures required. Where applying the fixture ratios in Table 422.1 results in fractional numbers, such numbers shall be rounded to the next whole number. For multiple occupancies, fractional numbers shall be first summed and then rounded to the next whole number.~~

Each building shall be provided with sanitary facilities as prescribed in Chapter 29, Table 2902.1 of the *Building Code*.

{EDITORIAL NOTE: DELETE TABLE 422.1.}

CHAPTER 5

WATER HEATERS

507.13 Installation in Garages. Appliances in garages and in adjacent spaces that open to the garage and are not part of the living space of a dwelling unit shall be installed so that burners, ignition sources, and burner-ignition devices are located not less than 18 inches (457 mm) above the floor unless listed as flammable vapor ignition resistant. [NFPA 54:9.1.10.1]

508.3.2 Access Type. The inside means of access shall be a permanent, ~~or fold-away~~ inside stairway or ladder, terminating in an enclosure, scuttle, or trap door. Such scuttles or trap doors shall be not less than 22 inches by 24 inches (559 mm by 610 mm) in size, pull-down stairway with a clear opening not less than 22 inches in width and a load capacity of not less than 350 pounds or a ladder permanently fastened to the building. Such a ladder or stairway shall not be more than 18 feet (5486 mm) in length between landings and not less than 14 inches (356 mm) in width and shall open easily and safely under all conditions, especially snow; and shall be constructed so as to permit access from the roof side unless deliberately locked on the inside. The ladder shall have rungs spaced not more than 14 inches (356 mm) center to center and not less than 7 inches (177.8 mm) from the face of the wall to the center of each rung. Each stile is to extend 30 inches (762 mm) above the surface to be reached, or as high as possible, if height is limited. Permanent ladders for water heater access need not be provided at parapets or walls less than 30 inches (762 mm) in height. All ladders shall be rated for a load capacity of not less than 350 pounds.

Not less than 6 feet (1829 mm) of clearance shall be between the access opening and the edge of the roof or similar hazard, or rigidly fixed rails or guards not less than 42 inches (1067 mm) in height shall be provided on the exposed side. Where parapets or other building structures are utilized in lieu of guards or rails, they shall be not less than 42 inches (1067 mm) in height. [NFPA 54:9.4.3.3]

508.4 Appliances in Attics and Under-Floor Spaces. An attic or under-floor space in which an appliance is installed shall be accessible through an opening and passageway not less than as large as the largest component of the appliance, ~~and not less than 22 inches by 30 inches (559 mm by 762 mm).~~ and shall be made accessible by a ladder or pull-down stairway with a clear opening not less than 22 inches in width and a load capacity of not less than 350 pounds or a ladder permanently fastened to the building with a load capacity of not less than 350 pounds.

Such a ladder or stairway shall not be more than 18 feet (5486 mm) in length between landings and not less than 14 inches (356 mm) in width. The ladder shall have rungs spaced not more than 14 inches (356 mm) center to center and not less than 7 inches (177.8 mm) from the face of the wall. Each stile is to extend 30 inches (762 mm) above the surface to be reached, or as high as possible, if height is limited.

Exception: A portable ladder may be used for access for water heaters in attics in buildings with lift out ceilings.

CHAPTER 6

WATER SUPPLY AND DISTRIBUTION

603.5.8.1 Discharge of water used for cooling. Water used for cooling of equipment or similar purposes shall not be returned to the potable water distributing system. When discharged to the building drainage system, wastewater shall be discharged through an indirect waste pipe or airgap.

603.5.19.2 Water Treatment Units. Reverse osmosis drinking water treatment units shall meet the requirements of the appropriate standards referenced in Table 1401.1. Waste or discharge from reverse osmosis or other types of water treatment units shall enter the drainage system through an airgap. Water supply for water softeners shall be protected by a double check valve assembly.

604.11 Lead Content. Water pipe and fittings with a lead content which exceeds 8 0.25 percent shall be prohibited in piping systems used to convey potable water.

606.8 Draindown Valve. A means for draining the building piping shall be installed at each building entry. The drain down valve shall not be installed in an underground service pipe, but shall be installed at a location in the pipe above ground before the pipe enters the building.

607.0 Gravity Supply Water Tanks.

607.2 Potable Water-Supply Tanks. Potable water-supply tanks, interior tank coatings, or tank liners intended to supply drinking water shall be in accordance with NSF 61. All potable water-supply tanks shall be properly covered or sealed to prevent entrance of foreign material into the water supply. Soil or waste lines shall not pass directly over nonpressure water-supply tanks or over manholes in pressure tanks.

607.3 Cleaning, Painting, Repairing Water-Supply Tanks. A potable water-supply tank for domestic purposes shall not be lined, painted or repaired with any material that is not in compliance with the current ANSI/AWWA D102 Standards and has not been approved by the Authority Having Jurisdiction.

607.4 When Required. When the water pressure from the public water main during flow is insufficient to supply fixtures that are likely to be in simultaneous operation, the supply shall be from a gravity house tank, pressure tank, or booster system.

No pumps are permitted to take suction directly from a jurisdiction main.

Exception: Pumps may be allowed to take suction from the jurisdiction main when approved by the Authority Having Jurisdiction if the main is of sufficient size as determined and approved by the Water Engineering Division of the jurisdiction’s Public Works and Engineering Department.

607.5 Overflow for Water-Supply Tanks. Overflow pipes for gravity tanks shall discharge above and within 6 inches of a roof drain, floor drain or catch basin, or they shall discharge into an open hub drain or water supplied sink. Adequate overflow pipes properly screened against the entrance of insects and vermin shall be provided.

607.6 Drains. Water-supply tanks shall be provided with valved drain lines located at their lowest point and discharged as indirect waste or as required for overflow pipes.

607.7 Tanks—Below-Rim Supply.

(1) Where a potable water outlet terminates below the rim of a tank, the tank shall have an overflow of diameter not less than that given in the following table:

TABLE 607.7

Sizes of Overflow Pipes for Water-supply Tanks

<u>Maximum Capacity of Water Supply Line to Tank</u>	<u>Diameter of Overflow Pipe (inches ID)</u>	<u>Maximum Capacity of Water-supply Line to Tank</u>	<u>Diameter of Overflow Pipe (inches ID)</u>
<u>0-50 gpm</u>	<u>2</u>	<u>400-700 gpm</u>	<u>5</u>
<u>50-150 gpm</u>	<u>2½</u>	<u>700-1,000 gpm</u>	<u>6</u>
<u>100-200 gpm</u>	<u>3</u>	<u>over 1,000 gpm</u>	<u>8</u>
<u>200-400 gpm</u>	<u>4</u>		

(2) The potable water inlet to the tank or vat shall terminate a distance of not less than one and one half times the height to which water can rise in the tank above the top of the overflow.

(3) The distance from the inlet to the high water level shall be measured from the critical point of the potable water supply overflow.

607.8 Construction of Tanks. Tanks used for potable water supply or to supply standpipes for fire-fighting equipment only shall be equipped with tight vermin-proof covers. Such tanks shall be vented with a return bend vent pipe having an area not less than one half of the area of the overflow riser. The vent opening and overflow riser shall be covered with a metallic screen of not less than 100 mesh. To provide an air gap, the top of the overflow riser shall not be less than 2 inches (50.8 mm) below the fill connection. The potable water supply shall be protected from contamination via the fire standpipe supply by a divided suction tank or a separate tank for potable water supply or by installing an approved backflow preventer on the downstream side of the fire pumps. When a divided tank is used, the tank shall be divided by a double wall partition extending to the top of the tank, and each wall shall be sealed with a continuous weld between the wall and four sides of the tank. There shall be an air space of not less than 4 inches (101.6

mm) between the walls of the partition, with an opening (not threaded) at the bottom of the partition to give visual evidence of loss of integrity of the walls of the partition (see Figure 6.5). The air space between the partition walls shall be given a 1.0 PSI air test with all welds soaked to assure no leaks in the partition chamber. The tank fabricator shall furnish a certificate of compliance with this test that also includes a statement that the coating materials are in compliance with the requirements of ANSI/AWWA D102 and NSF 61 and a metal nameplate on the tank giving the name of the fabricator, the date of fabrication, and a serial number. All tanks for potable water service shall be constructed of new material to assure against possibility of contamination from previous usage.

607.9 Piping. Water piping from potable gravity and suction tanks to the suction side of the water pumps and from the discharge end of the pumps to the check valve shall be galvanized.

607.10 Vacuum Breaker. Pressure tanks used for supplying water to the potable water distribution system, to both the fire standpipes and the potable system or to supply standpipes for fire equipment only, shall be equipped with an acceptable vacuum breaking device located on the top of the tank. The air inlet of this device shall be covered with a metallic screen of not less than 100 mesh.

609.3 Under Concrete Slab. Water piping installed within a building and in or under a concrete floor slab resting on the ground shall be installed in accordance with the following requirements:

- (1) Ferrous piping shall have a protective coating of an approved type, machine applied and in accordance with recognized standards. Field wrapping shall provide equivalent protection and shall be restricted to those short sections and fittings necessarily stripped for threading. Zinc coating (galvanizing) shall not be deemed adequate protection for piping or fittings. Approved nonferrous piping shall not be required to be wrapped.
- (2) Copper tubing shall be installed without joints where possible. Where joints are permitted, they shall be brazed, and fittings shall be wrought copper.

For the purpose of this section, "within a building" shall mean within the fixed limits of the building foundation.

609.3.1 Sleeves through Floors. Approved materials shall be installed without joints and must be sleeved where they penetrate the floor. Pipe sleeves shall have a minimum wall thickness of 1/16 inch. No portion of the water pipe shall be in contact with the concrete. In water services that are 3 inches or larger, one fitting may be installed under the slab within 5 feet of the exterior of the building. The fitting shall be installed to allow for replacement without any damage being done to the structure. Galvanized pipe shall not be used in or under slabs.

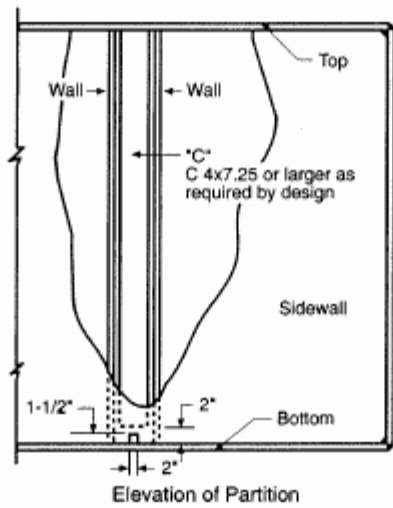
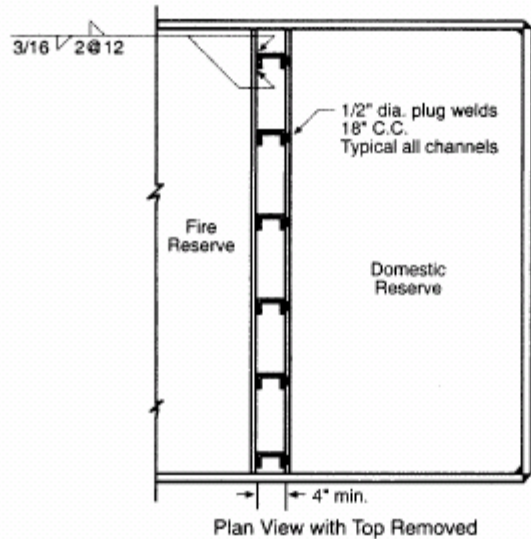

1. Tank must have a minimum of a 24-inch manway on each compartment.
2. Tank must have a ladder on the outside to access both manways.
3. Tank must have interior ladders inside to access bottom of tank from each manway.

FIGURE 6.5

CHAPTER 7

SANITARY DRAINAGE

701.1 Drainage Piping. Materials for drainage piping shall be in accordance with one of the referenced standards in Table 701.1 except that:

- (1) ~~No~~ Galvanized wrought-iron or galvanized steel pipe shall not be used underground and shall be kept not less than 6 inches (152 mm) aboveground.
- (2) ABS and PVC DWV piping installations shall be installed in accordance with applicable standards referenced in Table 1401.1 and Chapter 15 "Firestop Protection." Except for individual single-family dwelling units, materials exposed within ducts or plenums shall have a flame-spread index of a maximum of 25 and a smoke-developed index of a maximum of 50, where tested in accordance with ASTM E 84 and UL 723.
- (3) No vitrified clay pipe or fittings shall be used aboveground or where pressurized by a pump or ejector. They shall be kept not less than 12 inches (305 mm) belowground.
- (4) Copper tube for drainage and vent piping shall have a weight of not less than that of copper drainage tube Type DWV.
- (5) Stainless steel 304 pipe and fittings shall not be installed underground and shall be kept not less than 6 inches (152 mm) aboveground.
- (6) Cast-iron soil pipe and fittings shall be listed and tested in accordance with standards referenced in Table 1401.1. Such pipe and fittings shall be marked with country of origin and identification of the original manufacturer in addition to markings required by referenced standards.
- (7) SDR 35 plastic pipe shall be approved material for drainage piping size 8 inches or larger.

701.6 Below Slab. Piping installed below a slab on grade or mat type foundation shall be not less than 2 inches in diameter.

704.3 Commercial Dishwashing Machines and Sinks. Pot sinks, scullery sinks, dishwashing sinks, silverware sinks, commercial dishwashing machines, silverware-washing machines, and other similar fixtures shall be connected indirectly to the drainage system. ~~A floor drain shall be provided adjacent to the fixture, and the fixture shall be connected on the sewer side of the floor drain trap, provided that no other drainage line is connected between the floor drain waste connection and the fixture drain. The fixture and floor drain shall be trapped and vented as required by this code.~~

711.1 General. Drainage connections shall not be made into a drainage piping system within 8 feet (2438 mm) of a vertical to horizontal change of direction of a stack containing suds-producing fixtures. ~~Bathtubs, Laundries,~~ washing machine standpipes, kitchen sinks, and dishwashers shall be considered suds-producing fixtures. Where parallel vent stacks are required,

they shall connect to the drainage stack at a point 8 feet (2438 mm) above the lowest point of the drainage stack.

Exceptions:

- (1) Single-family residences.
- (2) Stacks receiving the discharge from less than three stories of plumbing fixtures.

713.4 Public Sewer Availability. The public sewer shall be permitted to be considered as not being available where such public sewer or building or an exterior drainage facility connected thereto is located more than 300 feet (60-960-91,440 mm) from ~~a proposed building or exterior drainage facility~~ on a lot or premises that abuts and is served by such public sewer.

715.1 Materials. The building sewer, beginning 2 feet (610 mm) from a building or structure, shall be of such materials as prescribed in this code. Pipe sizes 6 inches and smaller shall be PVC Schedule 40, and pipe sizes 8 inches or larger shall be permitted to be SDR 35.

722.1 Building (House) Sewer. An abandoned building (house) sewer, or part thereof, shall be plugged or capped in an approved manner within 5 feet (1524 mm) of the property line. Before any building may be demolished, a sewer disconnect permit shall be obtained and an inspection made to verify that the sewer has been properly capped within 5 feet of the property line and that the water service has been disconnected and capped at the meter.

724.0 Private Sewage Disposal Systems

724.1 General. Private sewage disposal systems shall conform to all applicable state laws and regulations, including the Construction Standards for Private Sewage Facilities, as published by the Texas Commission on Environmental Quality.

CHAPTER 8

INDIRECT WASTES

804.2 Accessible Receptors. Accessible indirect waste receptors may be fabricated utilizing a “P” trap, riser stub, and an increaser to form a funnel.

810.1 High Temperature Discharge. No steam pipe shall be directly connected to a plumbing or drainage system, nor shall water having a temperature above 140°F (60°C) be discharged under pressure directly into a drainage system. Pipes from boilers shall discharge by means of indirect waste piping, as determined by the Authority Having Jurisdiction or the boiler manufacturer’s recommendations. Such pipes shall be permitted to be indirectly connected by discharging into an open or closed condenser or an intercepting sump of an approved type that will prevent the entrance of steam or such water under pressure into the drainage system. Closed condensers or sumps shall be provided with a vent that shall be taken off the top and extended separately, full size above the roof. Condensers and sumps shall be properly trapped at the outlet with a deep seal trap extending to within 6 inches (152 mm) of the bottom of the tank. The top of the deep seal trap shall have a ¾ of an inch (19.1 mm) opening located at the highest point of the trap to serve as a siphon breaker. Outlets shall be taken off from the side in such a manner as to allow a waterline to be maintained that will permanently occupy not less than one-half the capacity of the condenser or sump. Inlets shall enter above the waterline. Wearing plates or baffles shall be installed in the tank to protect the shell. The sizes of the blowoff line inlet, the water outlets, and the vent shall be as shown in Table 810.1. The contents of condensers receiving steam or hot water under pressure shall pass through an open sump before entering the drainage system. Water above 113°F shall not be discharged to the jurisdiction's drainage system.

811.9 Sizing. An approved vented neutralizing basin is a basin with a bolted removable cover and dip-pipe outlet that is constructed of acid-resistant material such as molded seamless polyethylene, one-piece acid-proof chemical stoneware, lined carbon steel, or other material approved by the Authority Having Jurisdiction. Neutralizing basins shall be sized according to Table 811.9.

TABLE 811.9

NUMBER OF SINKS	TANK CAPACITY (GALLONS)
<u>1</u>	<u>5</u>
<u>4</u>	<u>15</u>
<u>8</u>	<u>30</u>
<u>16</u>	<u>55</u>
<u>25</u>	<u>100</u>
<u>40</u>	<u>150</u>
<u>60</u>	<u>200</u>
<u>75</u>	<u>275</u>
<u>100</u>	<u>350</u>
<u>200</u>	<u>675</u>
<u>300</u>	<u>1200</u>

500	2000
-----	------

1. Tank capacities are measured from invert inlet.
2. Neutralization basins receiving intermittent discharge from equipment shall be sized according to the manufacturer's recommendations. Sizing criteria shall be shown on drawings.

811.10 Material. Neutralization basins shall be provided with neutralizing material such as pieces of marble or limestone, 1 inch to 3 inches in size, so as to render effluent to a pH not less than 5 nor more than 11 before the effluent is discharged into the sewer system.

811.11 Sample Wells. Each chemical neutralization basin shall be provided with a sample well on the discharge side of the neutralization basin.

814.0 Condensate Wastes and Control. See the mechanical code.

~~**814.1 Condensate Disposal.** Condensate from air washers, air cooling coils, fuel burning condensing appliances, the overflow from evaporative coolers, and similar water-supplied equipment or similar air conditioning equipment shall be collected and discharged to an approved plumbing fixture or disposal area. If discharged into the drainage system, equipment shall drain by means of an indirect waste pipe. The waste pipe shall have a slope of not less than 1/8 inch per foot (10.5 mm/m) or one percent slope and shall be of approved corrosion-resistant material not smaller than the outlet size in accordance with Table 814.1 for condensing fuel-burning appliances, respectively. Condensate of wastewater shall not drain over a public way.~~

**TABLE 814.1
MINIMUM CONDENSATE PIPE SIZE**

EQUIPMENT CAPACITY IN TONS OF REFRIGERATION	MINIMUM CONDENSATE PIPE DIAMETER (inches)
Up to 20	3/4
21 - 40	1
41 - 90	1 1/4
91 - 125	1 1/2
126 - 250	2

For SI units: 1 ton = 3.52 kW, 1 inch = 25 mm

814.2 Size. The size of condensate waste pipes may be for one unit or a combination of units, or as recommended by the manufacturer. The capacity of waste pipes assumes a 1/8 inch per foot (10.4 mm/m) or 1 percent slope, with the pipe running three quarters full at the following pipe conditions:

Outside Air	20%	Room Air	80%
DB	WB	DB	WB
90°F	73°F	75°F	62.5°F

For SI units: °C = (°F-32)/1.8

~~— Condensate drain sizing for other slopes or other conditions shall be approved by the Authority Having Jurisdiction.~~

~~— Air conditioning waste pipes shall be constructed of materials specified in Chapter 7.~~

~~**814.3 Point of Discharge.** Air conditioning condensate waste pipes shall connect indirectly to the drainage system through an airgap or airbreak to properly trapped and vented receptors, dry wells, leach pits, or the tailpiece of plumbing fixtures.~~

~~— Condensate waste shall not drain over a public way.~~

CHAPTER 9

VENTS

908.2 Horizontal Wet Venting for a Bathroom Groups. A bathroom group located on the same floor level shall be permitted to be vented by a horizontal wet vent where all of the conditions of Section 908.2.1 through Section 908.2.5 are met. Water closets, bathtubs, showers, and floor drains within one or two bathroom groups located on the same floor level and for private use shall be permitted to be vented by a wet vent. The wet vent shall be considered the vent for the fixtures and shall extend from the connection of the dry vent along the direction of the flow in the drain pipe to the most downstream fixture drain or trap arm connection to the horizontal branch drain. Each wet vented fixture drain or trap arm shall connect independently to the wet vented horizontal branch drain. Each individual fixture drain or trap arm shall connect horizontally to the wet vented horizontal branch drain or shall be provided with a dry vent. The trap to vent distance shall be in accordance with Table 1002.2. Only the fixtures within the bathroom groups shall connect to the wet vented horizontal branch drain. The water closet fixture drain or trap arm connection to the wet vent shall be downstream of the fixture drain or trap arm connections. Additional fixtures shall discharge downstream of the wet vent system and be conventionally vented

908.2.1 Vent Connection. The dry vent connection to the wet vent shall be an individual vent or common vent for the lavatory, urinal, bidet, shower, or bathtub. One or two vented lavatory(s) shall be permitted to serve as a wet vent for a bathroom group. Only one wet-vented fixture drain or trap arm shall discharge upstream of the dry-vented fixture drain connection. All dry vent connections to the horizontal wet vent shall be in accordance with Section 905.2 and Section 905.3

908.2.2 Size. The wet vent shall be sized based on the fixture unit discharge into the wet vent. The wet vent shall be not less than 2 inches (50 mm) in diameter for 4 drainage fixture units (dfu) or less, and not less than 3 inches (80 mm) in diameter for 5 dfu or more. The dry vent shall be sized in accordance with Table 702.1 and Table 703.2 based on the total fixtures units discharging into the wet vent.

908.2.3 Trap Arm. The length of the trap arm shall not exceed the limits in Table 1002.2. The trap size shall be in accordance with Section 1003.3. The vent pipe opening from the horizontal wet vent, except for water closets and similar fixtures, shall not be below the weir of the trap.

908.2.4 Water Closet. The water closet fixture drain or trap arm connection to the wet vent shall be downstream of all fixture drain or trap arm connections to the horizontal wet vent.

908.2.5 Additional Fixtures. Additional fixtures shall discharge downstream of the wet vent system and be conventionally vented. Only the fixtures within the bathroom group shall connect to the wet-vented horizontal branch.

CHAPTER 10

TRAPS AND INTERCEPTORS

1009.8 Sample Wells. Each interceptor shall be provided with a sample well on the discharge side of the interceptor.

1011.1 General. A private or public wash rack, or floor or slab used for cleaning machinery or machine parts shall be adequately protected against storm or surface water and shall drain or discharge into an approved interceptor (clarifier). See Figure M.T-1, for minimum size and construction criteria.

Figure No. M.T 1

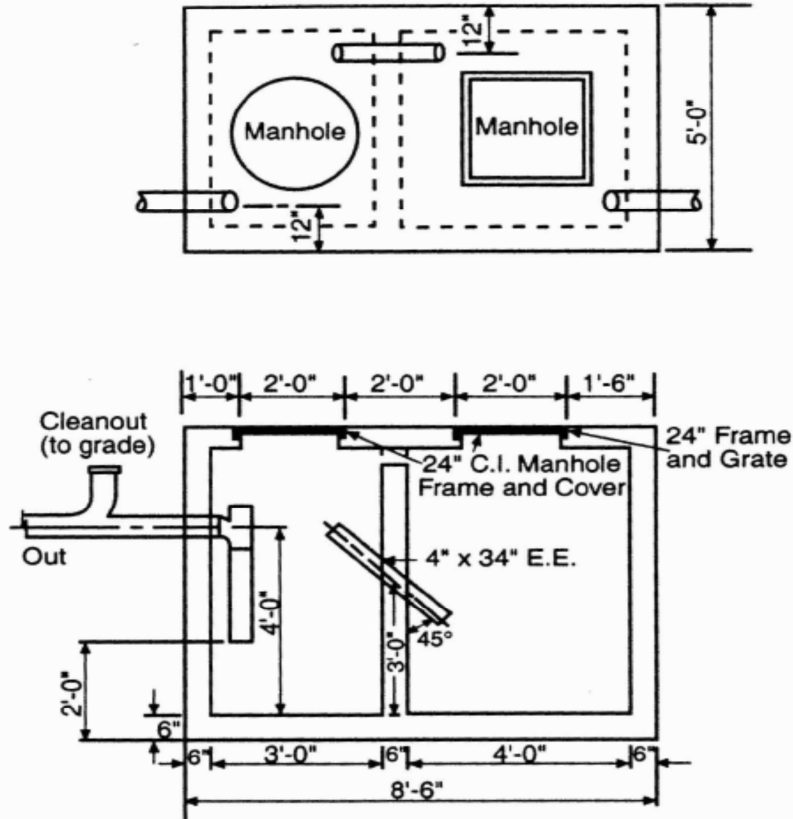

Based on Usage of Precast Unit
Mud and Grease Interceptor for Wash Rack

1012.1 General. Laundry equipment in commercial and industrial buildings that does not have integral strainers shall discharge into an interceptor having a wire basket or similar device that is removable for cleaning and that will prevent passage into the drainage system of solids $\frac{1}{2}$ of an inch (12.7 mm) or larger in maximum dimension, such as string, rags, buttons, or other solid materials detrimental to the public sewerage system.

An approved lint interceptor shall be installed for all commercial laundries.

Exceptions:

- (1) A laundry containing no more than 4 automatic clothes washers.
- (2) A laundry in an R-2 occupancy containing no more than 10 automatic clothes washers.

For other than a mechanical lint interceptor properly sized to manufacturer's instructions, see Figures L.T-1, L.T-2, and L.T-3 for minimum size and construction criteria.

Figure No. L.T. 1

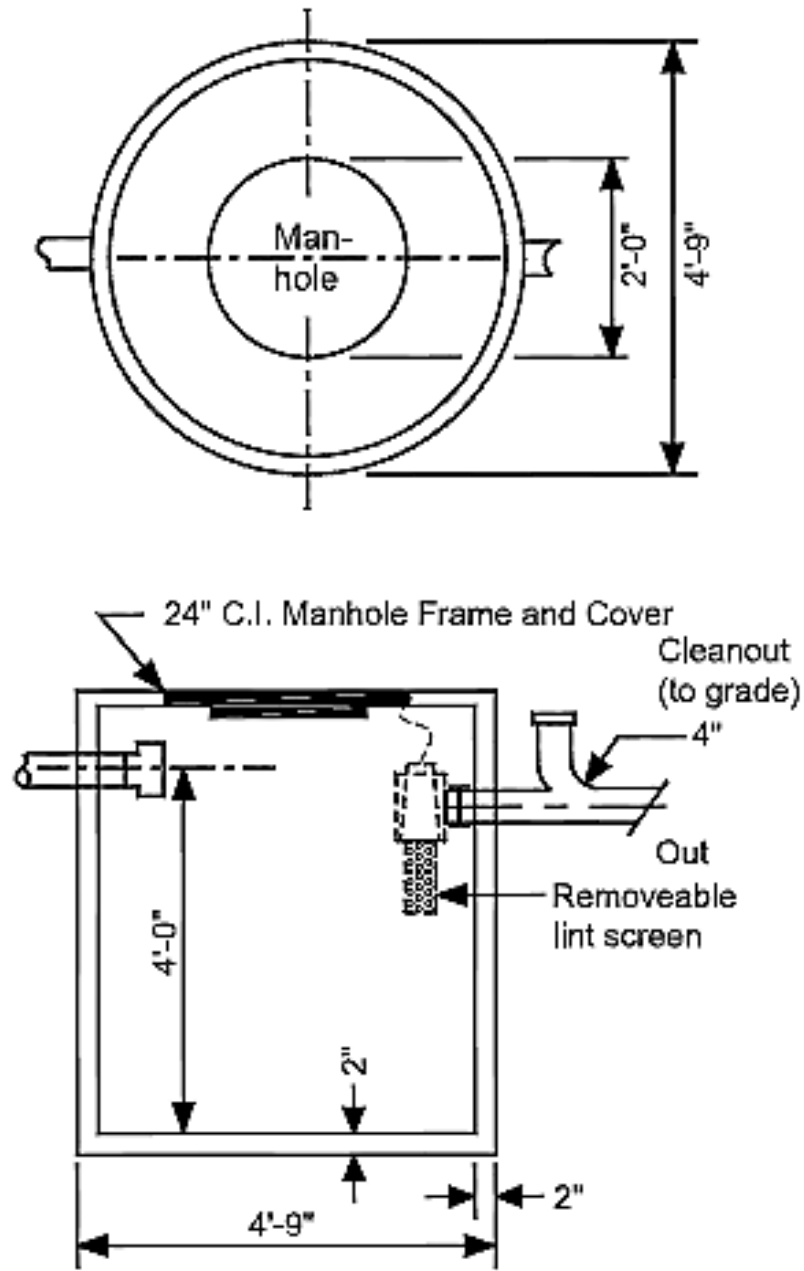

Based on Usage of Precast Unit

Lint Interceptor Washateria Operation for 5 to 10 Machines

Figure No. L.T. 2

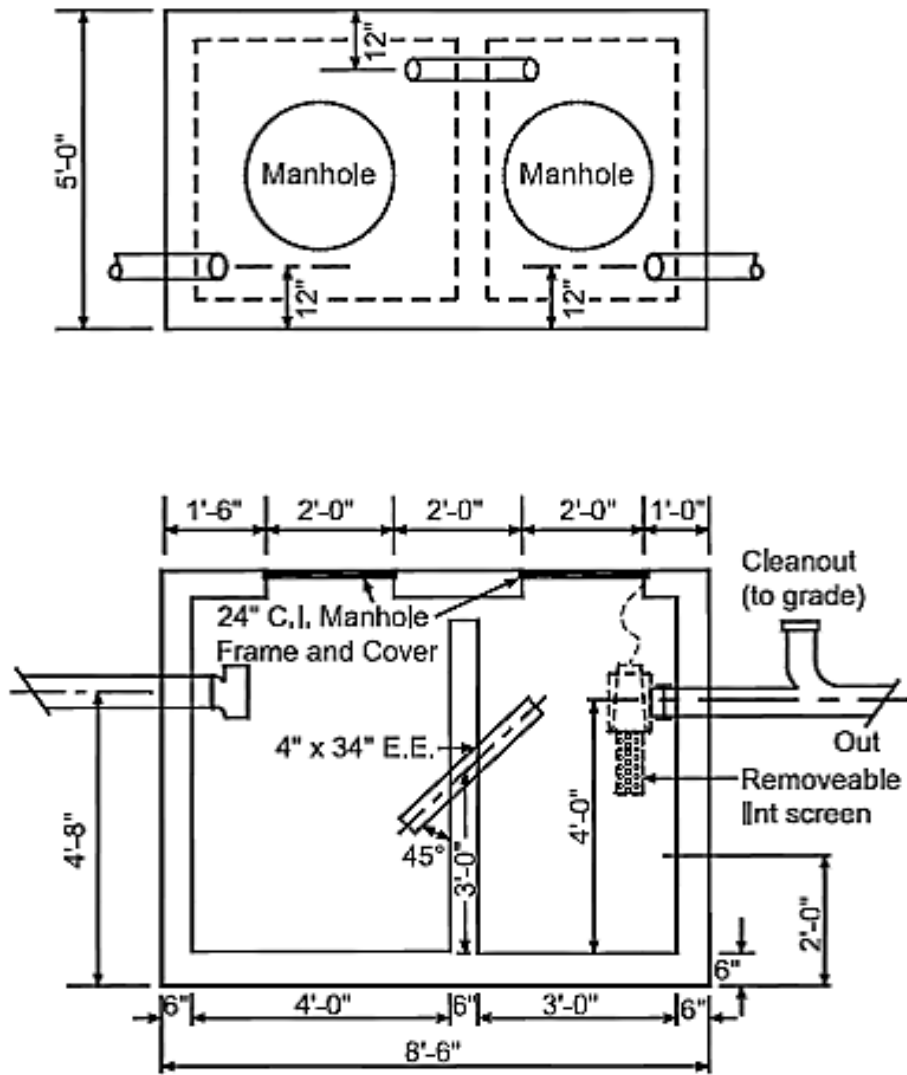

Based on Usage of Precast Unit

Lint Interceptor Washateria Operation for 11 to 20 Machines

Figure No. L.T. 3

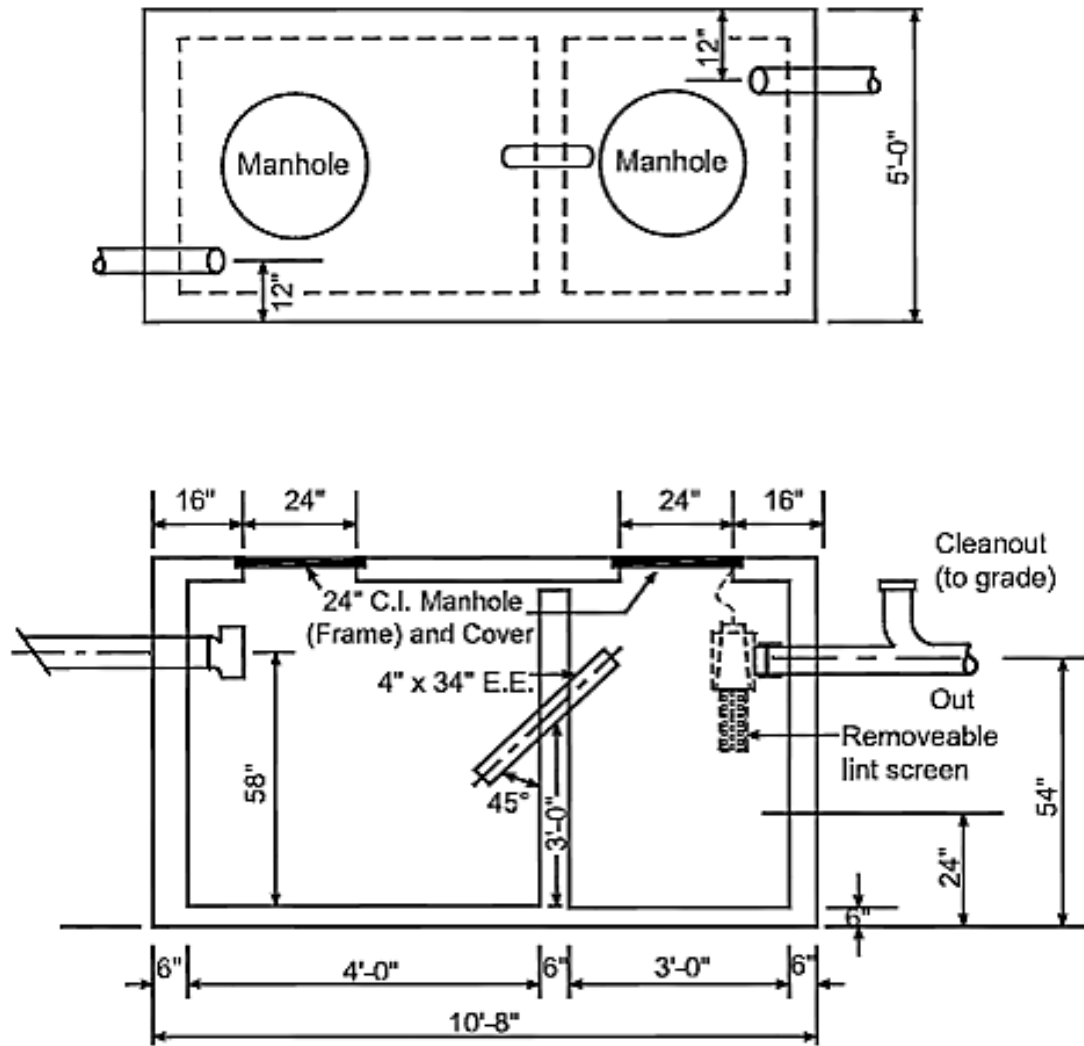

Based on Usage of Precast Unit

Lint Interceptor Washateria Operation for 21 to 30 Machines

Larger establishments and commercial-type laundries require an approved design by the project professional engineer.

1014.1.3 Food Waste Disposal Units and Dishwashers. Unless specifically required or permitted by the Authority Having Jurisdiction, no food waste disposal unit ~~or dishwasher~~ shall be connected to or discharge into any grease interceptor. Commercial food waste disposers shall be permitted to discharge directly into the building's drainage system.

1014.3.5 Construction Requirements. Gravity grease interceptors shall be designed to remove grease from effluent and shall be sized in accordance with this section. Gravity grease interceptors shall also be designed to retain grease until accumulations can be removed by pumping the interceptor. ~~It is recommended that a~~ A sample box well shall be located at the outlet end of gravity grease interceptors so that the Authority Having Jurisdiction can periodically sample effluent quality.

CHAPTER 11

STORM DRAINAGE

1101.3 Material Uses. Rainwater piping placed within the interior of a building or run within a vent or shaft shall be of cast-iron, galvanized steel, wrought iron, brass, copper, lead, Schedule 40 ABS DWV, Schedule 40 PVC DWV, SDR 35 for 8 inch or larger PVC, stainless steel 304 or 316L [stainless steel 304 pipe and fittings shall not be installed underground and shall be kept not less than 6 inches (152 mm) aboveground], or other approved materials, and changes in direction shall be in accordance with the requirements of Section 706.0. ABS and PVC DWV piping installations shall be installed in accordance with IS 5, IS 9, and Chapter 15 “Firestop Protection.” Except for individual single-family dwelling units, materials exposed within ducts or plenums shall have a flame-spread index of a maximum of 25 and a smoke-developed index of a maximum of 50, where tested in accordance ASTM E 84 and UL 723.

1101.11.1 Primary Roof Drainage. Roof areas of a building shall be drained by roof drains or gutters. The location and sizing of drains and gutters shall be coordinated with the structural design and pitch of the roof. Unless otherwise required by the Authority Having Jurisdiction, roof drains, gutters, vertical conductors or leaders, and horizontal storm drains for primary drainage shall be sized based on a storm rainfall rate of 8 inches per hour of 60 minutes duration and 100-year return period. ~~Refer to Table D-1.1 (in Appendix D) for 100-year, 60-minute storms at various locations.~~

1101.11.2.2.(B) Combined System. The secondary roof drains shall connect to the vertical piping of the primary storm drainage conductor downstream of a horizontal offset below the roof. The primary storm drainage system shall connect to the building storm water that connects to an underground public storm sewer. The combined secondary and primary roof drain systems shall be sized in accordance with Section 1106.0 ~~based on double the rainfall rate for the local area.~~

1101.14 Enclosed Parking Garages. Drains within an enclosed parking garage shall be routed to the sanitary waste drainage system. Drains routed to a sanitary system shall be provided with appropriate traps and shall be provided with a vent system. Vent system shall comply with Chapter 9. Drains located on the top level of the enclosed parking garage and directly exposed to rain water shall be drained to the storm drainage system. Traps and vents are not required on these drains.

1101.15 Open Parking Garages. All drains exposed to rain water and connected to the storm drainage system within an open parking garage shall not require a trap or to be vented.

1102.1.1 Inside of Conductors. The inside of conductors installed above ground level shall be of seamless copper water tube, Type K, L, or M; Schedule 40 copper pipe or

Schedule 40 copper alloy pipe; Type DWV copper drainage tube; service weight cast-iron soil pipe or hubless cast-iron soil pipe; standard weight galvanized steel pipe; stainless steel 304 or 316L [stainless steel 304 pipe and fittings shall not be installed underground and shall be kept not less than 6 inches (152 mm) above ground]; ~~or~~ Schedule 40 ABS or Schedule 40 PVC plastic pipe; or SDR 35 plastic pipe.

1102.2 Leaders. Leaders installed outside shall be in accordance with the applicable standards referenced in Table 701.1 for aboveground drain, waste, and vent pipe; aluminum sheet metal; galvanized steel sheet metal; ~~or~~ copper sheet metal; or SDR 35 plastic pipe.

**TABLE 1101.7
SIZING OF HORIZONTAL RAINWATER PIPING^{1,2}**

SIZE OF PIPE inches	FLOW (1/8 in./ft. slope) gpm	MAXIMUM ALLOWABLE HORIZONTAL PROJECTED ROOF AREAS AT VARIOUS RAINFALL RATES (square feet)						
		1 (in/h)	2 (in/h)	3 (in/h)	4 (in/h)	5 (in/h)	6 (in/h)	8 (in/h)
3	34	3288	1644	1096	822	657	548	<u>411</u>
4	78	7520	3760	2506	1880	1504	1253	<u>906</u>
5	139	13 360	6680	4453	3340	2672	2227	<u>1670</u>
6	222	21 400	10 700	7133	5350	4280	3566	<u>2675</u>
8	478	46 000	23 000	15 330	11 500	9200	7670	<u>5750</u>
10	860	82 800	41 400	27 600	20 700	16 580	13 800	<u>10 350</u>
12	1384	133 200	66 600	44 400	33 300	26 650	22 200	<u>16 650</u>
15	2473	238 000	119 000	79 333	59 500	47 600	39 650	<u>29 750</u>

SIZE OF PIPE inches	FLOW (1/4 in./ft. Slope) gpm	MAXIMUM ALLOWABLE HORIZONTAL PROJECTED ROOF AREAS AT VARIOUS RAINFALL RATES (square feet)						
		1 (in/h)	2 (in/h)	3 (in/h)	4 (in/h)	5 (in/h)	6 (in/h)	8 (in/h)
3	48	4640	2320	1546	1160	928	773	<u>580</u>
4	110	10 600	5300	3533	2650	2120	1766	<u>1325</u>
5	196	18 880	9440	6293	4720	3776	3146	<u>2360</u>
6	314	30 200	15 100	10 066	7550	6040	5033	<u>3775</u>
8	677	65 200	32 600	21 733	16 300	13 040	10 866	<u>8150</u>
10	1214	116 800	58 400	38 950	47 000	23 350	19 450	<u>14 600</u>
12	1953	188 000	94 000	62 600	47 000	37 600	31 350	<u>23 500</u>
15	3491	336 000	168 000	112 000	84 000	67 250	56 000	<u>43 000</u>

SIZE OF PIPE inches	FLOW (1/2 in./ft. Slope) gpm	MAXIMUM ALLOWABLE HORIZONTAL PROJECTED ROOF AREAS AT VARIOUS RAINFALL RATES (square feet)						
		1 (in/h)	2 (in/h)	3 (in/h)	4 (in/h)	5 (in/h)	6 (in/h)	8 (in/h)
3	68	6576	3288	2192	1644	1310	1096	<u>822</u>
4	156	15 040	7520	5010	3760	3010	2500	<u>1880</u>
5	278	26 720	13 360	8900	6680	5320	4450	<u>3340</u>

6	445	42 800	21 400	14 267	10 700	8580	7140	<u>5350</u>
8	956	92 000	46 000	30 650	23 000	18 400	15 320	<u>11 500</u>
10	1721	165 600	82 800	55 200	41 400	33 150	27 600	<u>20 700</u>
12	2768	266 400	133 200	88 800	66 600	53 200	44 400	<u>33 300</u>
15	4946	476 000	238 000	158 700	119 000	95 200	79 300	<u>59 500</u>

For SI units: 1 inch = 25 mm, 1 gallon per minute = 0.06 L/s, 1/8 inch per foot = 10.4 mm/m, 1 inch per hour = 25.4 mm/h, 1 square foot = 0.0929 m²

Notes:

1. The sizing data for horizontal piping are based on the pipes flowing full.
2. For rainfall rates other than those listed, determine the allowable roof area by dividing the area given in the 1 inch per hour (25 mm/h) column by the desired rainfall rate.

CHAPTER 12

FUEL PIPING

1201.3 Application. This code shall not apply to the following (reference standards for some of which appear in Chapter 14):

- (1) Portable LP-Gas appliances that are not connected to a fixed fuel piping system.
- (2) Installation of appliances such as brooders, dehydrators, dryers, and irrigation equipment used for agricultural purposes.
- (3) Raw material (feedstock) applications, except for piping to special atmosphere generators.
- ~~(4) Oxygen-fuel gas cutting and welding systems.~~
- ~~(5) Industrial gas applications using gases such as acetylene and acetylenic compounds, hydrogen, ammonia, carbon monoxide, oxygen, and nitrogen.~~
- ~~(4)(6)~~ Petroleum refineries, pipeline compressor or pumping stations, loading terminals, compounding plants, refinery tank farms, and natural gas processing plants.
- ~~(5)(7)~~ Large integrated chemical plants or portions of such plants where flammable or combustible liquids or gases are produced by chemical reactions or used in chemical reactions.
- ~~(6)(8)~~ LP-Gas installations at utility gas plants.
- ~~(7)(9)~~ Liquefied natural gas (LNG) installations.
- ~~(8)(10)~~ Fuel gas piping in electric utility ~~power~~ plants.
- ~~(9)(11)~~ Proprietary items of equipment, apparatus, or instruments such as gas-generating sets, compressors, and calorimeters.
- ~~(10)(12)~~ LP-Gas appliances for vaporization, gas mixing, and gas manufacturing.
- ~~(11)(13)~~ LP-Gas piping for buildings under construction or renovations that are not to become part of the permanent building piping system—that is, temporary fixed piping for building heat.
- ~~(12)(14)~~ Installation of LP-Gas systems for railroad switch heating.
- ~~(13)(15)~~ Installation of LP-Gas and compressed natural gas systems on vehicles.
- ~~(14)(16)~~ Gas piping, meters, gas-pressure regulators, and other appurtenances used by the serving gas supplier in distribution of gas, other than undiluted LP-Gas. [NFPA 54-12: 1.1.1.2]
- (15) Liquid petroleum gas facilities regulated by the Railroad Commission of Texas pursuant to Chapter 113 of the Texas Natural Resources Code.

1201.4 Other requirements. All fuel oil facilities and piping shall conform to the requirements of Chapter 57 of the City of Houston fire code.

1201.5 Gas Tests. A permit shall be required for all gas tests. Gas systems shall require a complete test and inspection in the following circumstances:

- (1) During rough inspection and before startup of new installations.
- (2) Before resumption of use of a system where service has been interrupted for more than 365 days for any reason.
- (3) Before resumption of use of a system where service has been interrupted for any period of time because of one or more leaks or a fire.
- (4) When the system was found to be unsafe by the serving gas supplier or the Authority Having Jurisdiction.
- (5) Where required by the City of Houston fire code.
- (6) Where service is not commenced within 180 days following a gas test.

1202.1 Installation. The regulations of this chapter shall govern the installation of fuel gas piping, other than service pipe, in or in connection with a building or structure or within the property lines of any premises up to 5 pounds force per square inch (34 kPa), other than service pipe. Fuel oil piping systems shall be installed in accordance with NFPA 31.

Exception: Gas piping, meters, gas-pressure regulators, and other appurtenances used by the serving gas supplier in distribution of gas, other than undiluted LP-Gas [NFPA 54: 1.1.1.2(16)]

1203.3.1 Rough Piping Inspection. This inspection shall be made after gas piping within the building authorized by the permit has been installed and before such piping has been covered or concealed or fixture or appliance has been attached thereto. This inspection shall include a determination that the gas piping size, material, and installation meet the requirements of this code. This inspection shall also include a pressure test. The gas piping shall pass an air pressure test of 25 psi for a period of 15 minutes with no perceptible drop.

Exception: For metal welded piping, the test pressure shall be not less than 100 psi (689 kPa) for 30 minutes. These tests shall be made using air, CO₂, or nitrogen pressure only and shall be made in the presence of the inspector. All necessary apparatus for conducting tests shall be furnished by the permit holder.

1203.3.2 Final Piping Inspection. This inspection shall be made after piping authorized by the permit has been installed and after portions thereof that are to be covered or concealed are so concealed and before any fixture, appliance, or shutoff valve has been attached thereto and after the completed system is ready to be put into service. This inspection shall comply with Section 1213.43. Test gauges used in conducting tests shall be in accordance with Section 318.0.

1208.6.1.3 Additional Requirements. Gas meters shall not be located under a show window or under interior stairways or in engine, boiler, heater, or electric meter rooms. Gas meters shall be located at least 3 feet (914 mm) from known sources of ignition or air intakes.

1210.1.6 Piping Underground Beneath Buildings. Where gas piping is installed underground beneath buildings, the piping shall be either:

- (1) Encased in an approved conduit designed to withstand the imposed loads and installed in accordance with Section 1210.1.6.1 or Section 1210.1.6.2.
- (2) A piping or encasement system listed for installation beneath buildings. [NFPA54-12:7.1.6]

Pipe must be removable without causing damage to the structure. Sleeves for corrugated stainless steel piping may terminate within the building.

1210.1.6.1 Conduit with One End Terminating Outdoors. The conduit shall extend into a normally usable and accessible portion of the building and, at the point where the conduit terminates in the building, the space between the conduit and the gas piping shall be sealed to prevent the possible entrance of a gas leakage. Where the end sealing is of a type that will retain the full pressure of the pipe, the conduit shall be designed for the same pressure as the pipe. The conduit shall extend not less than 4 inches (102 mm) outside the building, be vented outdoors above finished ground level, ~~and~~ be installed so as to prevent the entrance of water and insects, and be graded to the outside. [NFPA 54:7.1.6.1]

1210.1.7.2 Tracer Wire. An electrically continuous corrosion-resistant tracer wire (not less than AWG 14 yellow) or tape shall be buried with the plastic pipe to facilitate locating. One Both ends shall terminate ~~be brought~~ aboveground at a building wall or riser. [NFPA 54:7.1.7.3]

1210.3.4 Piping in Floors. In industrial occupancies, gas piping in solid floors such as concrete shall be laid in channels in the floor and covered to permit access to the piping with minimum damage to the building. Where piping in floor channels is exposed to excessive moisture or corrosive substances, the piping shall be protected in an approved manner. [NFPA 54:7.3.5.1]

~~**Exception:** In other than industrial occupancies and where approved by the Authority Having Jurisdiction, gas piping embedded in concrete floor slabs constructed with portland cement shall be surrounded with not less than 1½ inches (38 mm) of concrete and shall not be in physical contact with other metallic structures such as reinforcing rods or electrically neutral conductors. Piping, fittings, and risers shall be protected against corrosion in accordance with Section 1208.5.6. Piping shall not be embedded in concrete slabs containing quick-set additives or cinder aggregate. [NFPA 54:7.3.5.2]~~

1213.3 Test Pressure. This inspection shall include an air, CO₂, or nitrogen pressure test, at a pressure of at least 6 inches (152 mm) of mercury, measured with a manometer or slope gauge ~~at which time the gas piping shall stand a pressure of not less than 10 psi (69 kPa) gauge pressure.~~ Test pressures shall be held for a length of time satisfactory to the Authority Having Jurisdiction, but in no case less than 15 minutes with no perceptible drop in pressure. The test pressure shall not be less than twice the pressure that the system will be subjected to when in service. These tests shall be made in the presence of an inspector. All necessary apparatus for conducting tests shall be furnished by the permit holder. A final inspection shall be required for all gas systems that require a permit as specified in Section 1201.5. For annual gas tests and GTO's, the tests shall be done at the pressure required for the final gas inspection.

Exception: In lieu of the mercury gauge one of the following may be used:

- (1) Low Pressure Systems - A low pressure diaphragm gauge with a minimum dial size of 3 1/2 inches with a set hand and a pressure range not to exceed 6 psi with 1/10 pound incrementation. The minimum test pressure shall not be less than 3 psi and the maximum test pressure to be applied shall not exceed 4 psi.
- (2) Medium Pressure Systems - A diaphragm type pressure gauge with a minimum dial size of 3 1/2 inches with a set hand and a pressure range not to exceed 20 psi with 2/10 pound incrementation. The minimum test pressure shall not be less than 10 psi and the maximum test pressure shall not exceed 12 psi.
- (3) High Pressure Systems - Gauges for high pressure tests shall be as follows:
 - A. Required pressure tests exceeding ten (10) pounds (69 kPa) but less than 100 pounds (689 kPa) shall be performed with gauges that have 1 pound (6.9 kPa) incrementation or less.
 - B. Required pressure tests exceeding 100 pounds (689 kPa) shall be performed with gauges incremented for 2 percent or less of the required test pressure.
 - C. Test gauges shall have a pressure range not greater than twice the test pressure applied.

~~For welded piping, and for piping carrying gas at pressures in excess of 14 inches water column pressure (3.5 kPa), the test pressure shall be not less than 60 psi (414 kPa) and shall be continued for a length of time satisfactory to the Authority Having Jurisdiction, but in no case for less than 30 minutes. These tests shall be made using air, CO₂, or nitrogen pressure and shall be made in the presence of the Authority Having Jurisdiction. Necessary apparatus for conducting tests shall be furnished by the permit holder. Test gauges used in conducting tests shall be in accordance with Section 318.0.~~

CHAPTER 13

HEALTH CARE FACILITIES AND MEDICAL GAS AND VACUUM SYSTEMS

1310.5 Health Care Organization Personnel. ~~Health Care Organization personnel shall be permitted to install piping systems if all the requirements of this chapter are met during installation. [NFPA 99:5.1.10.10.11.5]~~ **Piping and Installation.** Piping and installation procedures shall comply with NFPA 99, latest edition, as adopted by the Texas Department of Health.

CHAPTER 16

ALTERNATE WATER SOURCES FOR NONPOTABLE APPLICATIONS

1601.2 System Design. Alternate water source systems in accordance with this chapter shall be designed by a person registered or licensed to perform plumbing design work. Components, piping, and fittings used in an alternate water source system shall be listed

Exceptions:

- (1) A person registered or licensed to perform plumbing design work is not required to design rainwater catchment systems used for irrigation with a maximum storage capacity of 360 gallons (1363 L).
- (2) A person registered or licensed to perform plumbing design work is not required to design rainwater catchment systems for single family dwellings where outlets, piping, and system components are located on the exterior of the building.
- (3) A person registered or licensed to perform plumbing design work is not required to design gray water systems having a maximum discharge capacity of 250 gallons per day (gal/d) (0.011 L/s) for single family and multi-family dwellings.
- (4) A person registered or licensed to perform plumbing design work is not required to design an on-site treated nonpotable water system for single family dwellings having a maximum discharge capacity of 250 gal/day (0.011 L/s) per day.

Systems subject to Title 30 of the Texas Administrative Code shall be designed and installed as required by the Texas Commission on Environmental Quality and the Texas State Board of Plumbing Examiners.

CHAPTER 17

NONPOTABLE RAINWATER CATCHMENT SYSTEMS

1702.9.3.1 Prohibited Discharges. Except for air conditioning condensate, overflows and bleed-off pipes from roof-mounted equipment and appliances shall not discharge onto roof surfaces that are intended to collect rainwater.

APPENDIX C

ALTERNATE PLUMBING SYSTEMS

C 7 .2.1 Vacuum Generating System. The vacuum generating station shall include vacuum pumps to create a constant vacuum pressure within the piping network and storage tanks. ~~The discharge from the tank shall be through an airgap in accordance with Table 603.3.1.~~ Operation of pumps, collection tanks, and alarms shall be automated by controls. The vacuum pumps shall be activated on demand and accessible for repair or replacement. The vent from the vacuum pump shall be provided for vacuum pump air exhaust, and shall be of a size capable of handling the total air volume of the vacuum pump.

APPENDIX K

POTABLE RAINWATER CATCHMENT SYSTEMS

K 101.2 System Design. Potable rainwater catchment systems in accordance with this appendix shall be designed by a person registered, licensed, or deemed competent by the Authority Having Jurisdiction to perform potable rainwater catchment system design work. Systems subject to Title 30 of the Texas Administrative Code shall be designed and installed as required by the Texas Commission on Environmental Quality and the Texas State Board of Plumbing Examiners.

K 104.3.3 Exposure to Sunlight. Rainwater tank openings that are subject to degradation when exposed to sunlight shall not be exposed to direct sunlight.